



Chipsmall Limited consists of a professional team with an average of over 10 year of expertise in the distribution of electronic components. Based in Hongkong, we have already established firm and mutual-benefit business relationships with customers from,Europe,America and south Asia,supplying obsolete and hard-to-find components to meet their specific needs.

With the principle of "Quality Parts,Customers Priority,Honest Operation,and Considerate Service",our business mainly focus on the distribution of electronic components. Line cards we deal with include Microchip,ALPS,ROHM,Xilinx,Pulse,ON,Everlight and Freescale. Main products comprise IC,Modules,Potentiometer,IC Socket,Relay,Connector.Our parts cover such applications as commercial,industrial, and automotives areas.

We are looking forward to setting up business relationship with you and hope to provide you with the best service and solution. Let us make a better world for our industry!



Contact us

Tel: +86-755-8981 8866 Fax: +86-755-8427 6832

Email & Skype: info@chipsmall.com Web: www.chipsmall.com

Address: A1208, Overseas Decoration Building, #122 Zhenhua RD., Futian, Shenzhen, China



LT1336 Half-Bridge N-Channel Power MOSFET Driver with Boost/Flyback Regulator

DESCRIPTION

This demonstration circuit is an N-channel half-bridge for general purpose applications. The half-bridge can be driven with TTL/CMOS level signals into an LT[®]1336, which drives the N-channel MOSFETs. A self-contained high-side driver regulator allows PWM operation to 100% duty cycle without discontinuities. By adding a controller IC and

some other components in the space provided for prototyping, this demo board can be turned into a complete system solution. The half-bridge consists of four power MOSFETs, two paralleled topside MOSFETs and two paralleled bottom side MOSFETs.

LT, LTC and LT are registered trademarks of Linear Technology Corporation.

PERFORMANCE SUMMARY Operating Temperature Range 0°C to 50°C, V_{IN} = 12V unless otherwise noted.

SYMBOL	PARAMETER	CONDITION	VALUE
V _{IN}	LT1336 Input Voltage Range		10V to 15V
I _Q	LT1336 Typical Supply Current	INTOP = INBOTTOM = 0V	15mA
HV	High Voltage Range		0V to 50V (60V Abs Max)
R _{DS(ON)}	Power MOSFETs R _{DS(ON)}	V _{GS} = 10V	0.09Ω
ESR	ESR of Bypass Capacitor	100kHz	0.03Ω
I _{PK}	Max Ripple Current		4.5A
P _{IN}	Max Power Input	(Note 1)	150W
f _{MAX}	Max Operating Frequency		100kHz

Note 1: For applications requiring higher input power, attach heat sinks to all power MOSFETs.

BOARD PHOTOS

Demo Board with a Flyback High-Side Driver Regulator

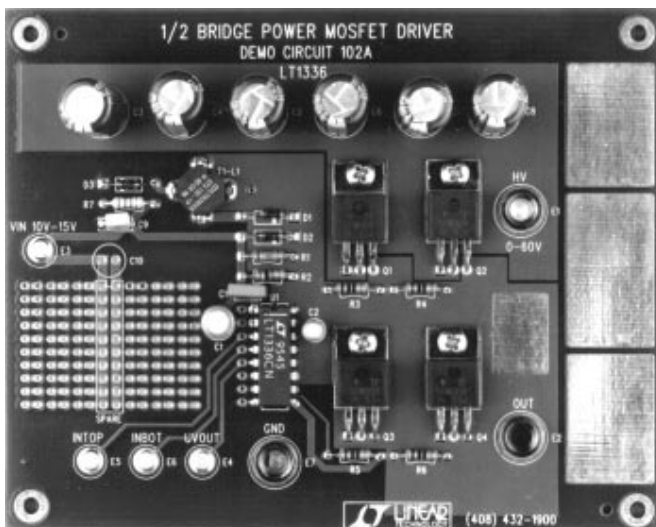

Demo Board with a Boost High-Side Driver Regulator

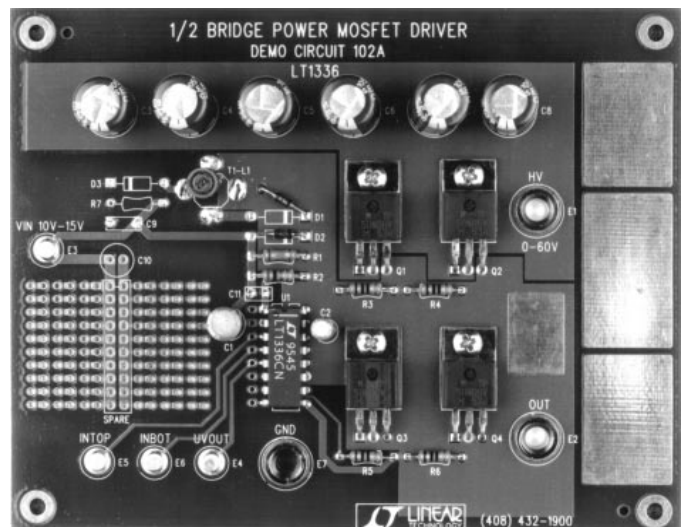

PACKAGE AND SCHEMATIC DIAGRAMS

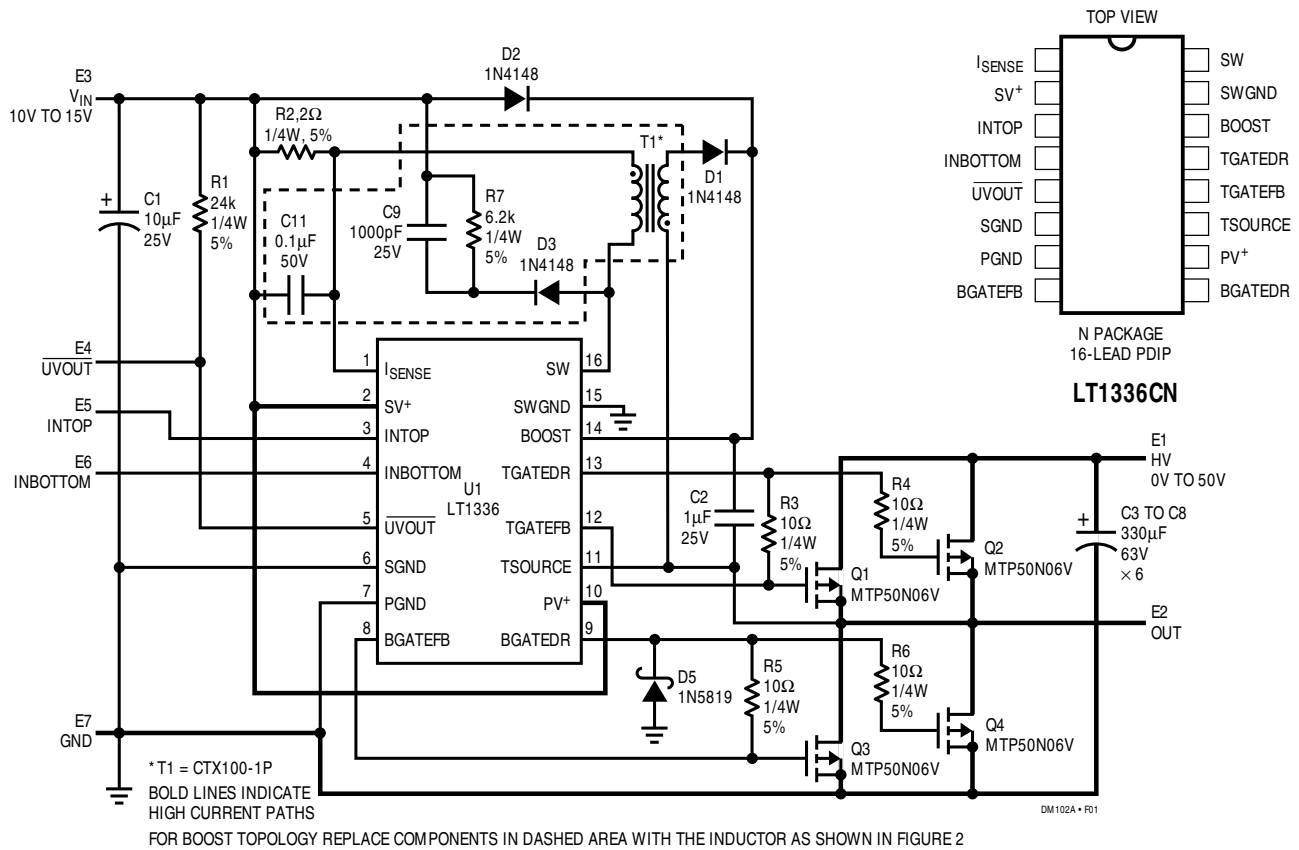

Figure 1. Demonstration Circuit with a Flyback High-Side Driver Regulator

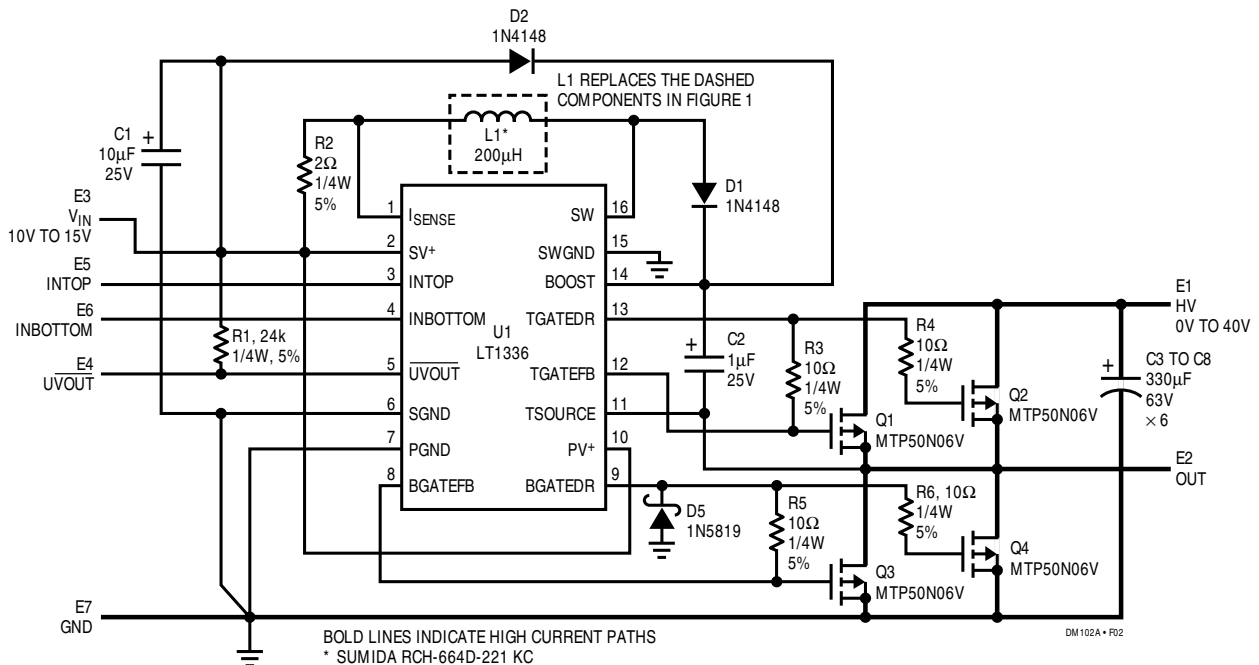

Figure 2. Demonstration Circuit with a Boost High-Side Driver Regulator

PARTS LIST

REFERENCE DESIGNATOR	QUANTITY	PART NUMBER	DESCRIPTION	VENDOR	TELEPHONE
C1	1	25SC10M	10 μ F 25V 20% Electrolytic Capacitor	Sanyo	(619) 661-6835
C2	1	25SC1M	1 μ F 25V 20% Electrolytic Capacitor	Sanyo	(619) 661-6835
C3 to C8	6	63MV330CZ	330 μ F 63V Aluminum Capacitor	Sanyo	(619) 661-6835
C9	1	FKC02	1000pF 25V 10% Mylar Capacitor	WIMA	(914) 347-2474
C10	1	25SC10M	Option Capacitor	Sanyo	(619) 661-6835
C11	1	MKS2	0.1 μ F 63V 5% Mylar Capacitor	WIMA	(914) 347-2474
D1 to D3	3	1N4148	Diode	Philips	(800) 774-4547
D5	1	1N5819	Diode	Motorola	(602) 244-3576
L1	1	RCR-664D-221KC	0.99 Ω 0.30A Inductor (Optional)	Sumida	(847) 956-0666
Q1 to Q4	4	MTP50N06V	50A 60V TO-220 MOSFET	Motorola	(602) 244-3576
R1 to R7	7		1/4W 5% Resistor	Any	
T1	1	CTX100-1P	Transformer	Coiltronics	(407) 241-7876
U1	1	LT1336	IC	LTC	(408) 432-1900

QUICK START GUIDE

Demonstration board 102 is easily set up for evaluation of the LT1336 IC. Please follow the procedure below for error-free operation.

- Connect the positive lead of a low power supply to V_{IN} (E3) and the negative lead to GND (E7). The voltage range of this supply must be between 10V – 15V.
- Connect the positive lead of a high power supply to HV (E1) and the negative lead to GND (E7). The recommended maximum operating voltage is 50V. The capacitors, the MOSFETs and the IC are rated at 60V absolute maximum.
- Connect the driving signals into INTOP (E5) and INBOTTOM (E6). Taking INTOP high and INBOTTOM low turns the top MOSFETs on and the bottom MOSFETs off. Taking INTOP low and INBOTTOM high reverses these states. When both inputs are either high or low, all the MOSFETs are off. These inputs are TTL/CMOS compatible and can withstand input voltages as high as V_{IN} .
- Connect the load between OUT (E2) and GND (E7).

OPERATION

A general purpose half-bridge is implemented using the LT1336. Figure 1 is the schematic for this demonstration board. The half-bridge can be used as a building block for a number of different applications, including synchronous switching regulators, motor control and class-D amplifiers. By adding the appropriate controller IC in the prototyping space, a complete system solution can be created.

This demonstration unit is intended for the evaluation of the LT1336 half-bridge driver and was not designed for any other purpose.

To power this demo board, connect a low power 10V to 15V supply to V_{IN} (E3) and a high power supply, up to 50V to HV (E1). To evaluate the LT1336 driving the half-bridge, connect two complementary signals from a function

DEMO MANUAL DC102

50V N-CHANNEL HALF BRIDGE

OPERATION

generator to INTOP (E5) and INBOTTOM (E6). These inputs to the LT1336 are TTL/CMOS compatible and can withstand input voltages as high as V_{IN} . Both driver channels are noninverting. The internal logic of the LT1336 prevents the top MOSFETs and bottom MOSFETs from turning on simultaneously under any input conditions. For instance, when both inputs are high both outputs are actively held low.

The LT1336 incorporates a small switching regulator to charge the floating high-side driver supply above the high voltage rail. This regulator can provide enough charge to the floating supply capacitor to allow the top driver to drive several power MOSFETs in parallel at 100kHz, its maxi-

imum operating frequency. The regulator voltage across $V_{BOOST} - V_{TSOURCE}$ is 10.6V. Unlike bootstrapping techniques with internal charge pumps, the built-in regulator enables the half-bridge to operate from PWM to DC without discontinuities.

In conventional half-bridge drivers using bootstrapping techniques and internal charge pumps, approaching DC may cause some serious problems. When the duty cycle approaches 100%, the output pulse width becomes too narrow for the floating capacitor to recharge. This capacitor is being continuously depleted by the gate charging currents of the top MOSFETs. The internal charge pump is too weak to provide the currents needed to replenish the

Functional Diagram for the LT1336

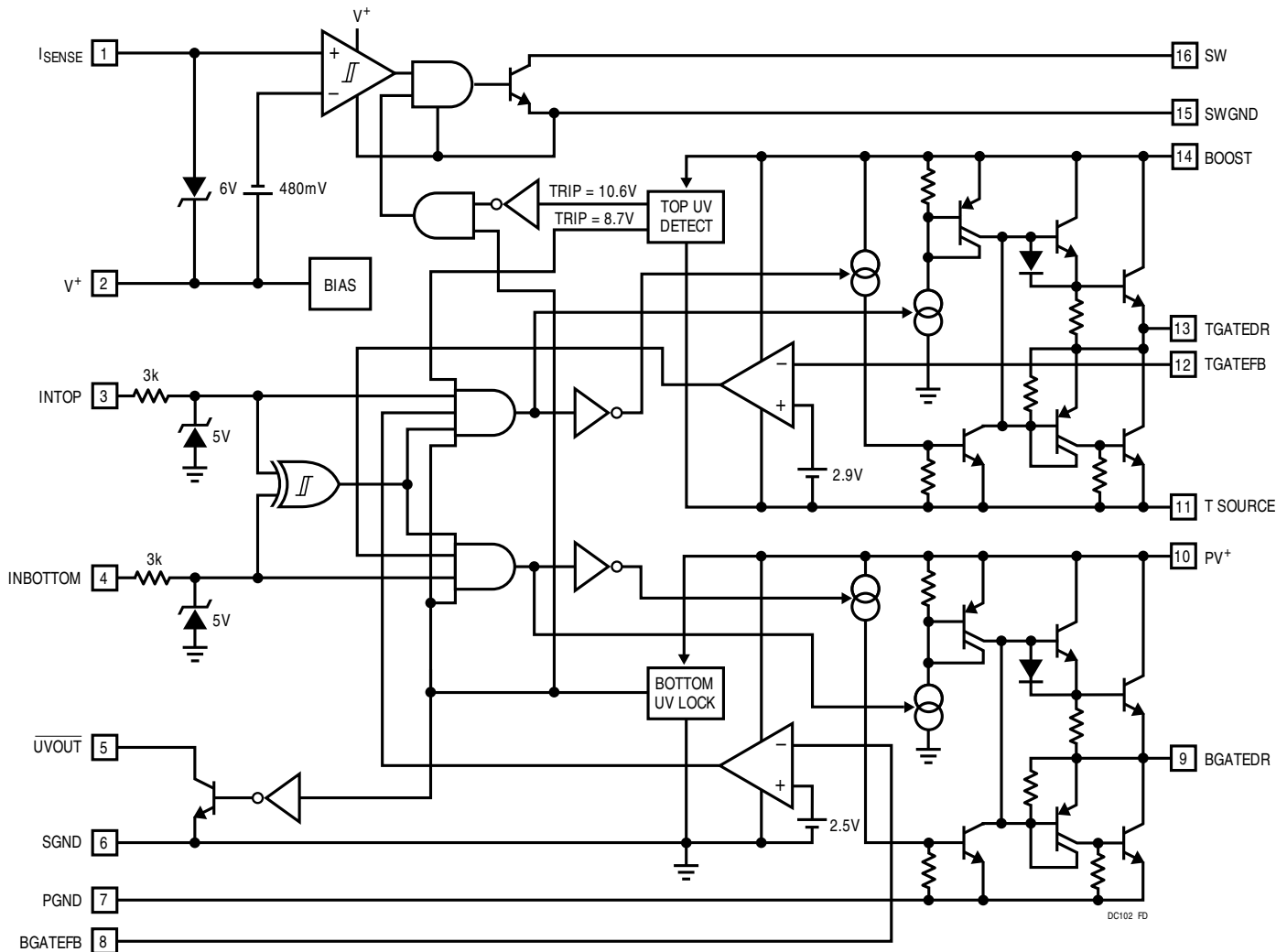

OPERATION

floating capacitor. Thus, at a point between 90% and 100% duty cycles, the floating capacitor will be depleted, causing a discontinuity and potential overdissipation of the top MOSFETs.

In this demo board the built-in switching regulator of the LT1336 comes configured as a flyback regulator, as shown in Figure 1. To configure a flyback regulator, a resistor, a diode, a small 1:1 turns ratio transformer and a capacitor are needed. The maximum voltage across the switch, assuming an ideal transformer, will be about $V_{IN} + 11.3V$. Leakage inductance in nonideal transformers will induce an overvoltage spike at the switch the instant that it opens. These spikes are clamped using the snubbing network D3, C9 and R7. Using the components as shown in Figure 1, the flyback regulator will run at around 800kHz. To lower the frequency, increase the value of C11; to raise the frequency, decrease the value of C11.

The flyback regulator works as follows: when the switch is on, the primary current ramps up as the magnetic field builds up. The magnetic field in the core induces a voltage on the secondary winding equal to V_{IN} . However, no power is transferred to V_{BOOST} because the rectifier diode D1 is reverse biased. The energy is stored in the transformer's magnetic field. When the primary inductor peak current is reached, the switch is turned off. Energy is no longer transferred to the transformer, causing the magnetic field to collapse. The collapsing magnetic field induces a change in voltage across the transformer's windings. During this transition the Switch pin's voltage flies to 10.6V plus a diode above V_{IN} , the secondary forward biases the rectifier diode D1 and the transformer's energy is transferred to V_{BOOST} . Meanwhile, the primary inductor current goes to zero and the voltage at I_{SENSE} decays to the lower inductor current threshold with a time constant of $(R2)(C11)$, thus completing the cycle.

Using the flyback regulator allows the maximum voltage (50V) to be applied at the high voltage rail, HV. In applica-

tions where the high voltage rail does not exceed 40V, the boost topology can be used. The advantage, as shown in Figure 2, is simplicity. Only a resistor, a small inductor, a diode and a capacitor are needed; there is no need for a snubber circuit. The current drawn from V_{IN} will be higher, however, by a factor of V_{BOOST}/V_{IN} .

To reconfigure the demo board's flyback regulator into a boost regulator, remove the snubber circuit's components, C9, R7, D3 and the transformer T1. Reconnect diode D1 and insert the optional inductor as shown in the Board Photos. Using the components provided with the demo board (2Ω sense resistor, 200μH inductor and 1μF capacitor) the boost regulator will run at around 700kHz. To lower the frequency increase the inductor value; to increase the frequency decrease the inductor value.

The boost regulator works as follows: when the switch is on, the inductor current ramps up as the magnetic field builds up. During this interval energy is being stored in the inductor and no power is transferred to V_{BOOST} . When the 2Ω resistor senses that the peak inductor current has been reached, the switch is turned off. Energy is no longer transferred to the inductor, causing the magnetic field to collapse. The collapsing magnetic field induces a change in voltage across the inductor. The Switch pin's voltage rises until diode D1 starts conducting. As the inductor current ramps down, the lower inductor current threshold is reached and the switch is turned on, starting the next cycle.

Current drawn from V_{IN} is delivered to V_{BOOST} . Some of this current (~1.5mA) flows through the topside driver to E2. This current is typically returned to ground via the bottom MOSFETs or the output load. If the bottom MOSFETs are off and the output load is returned to HV, E2 will return the current to HV through the top MOSFET or the output load. If the HV supply cannot sink current and no load drawing greater than 1.5mA is connected to the supply, a resistor from HV to ground may be needed to prevent voltage buildup on the HV supply.

PC LAYOUT AND FILM

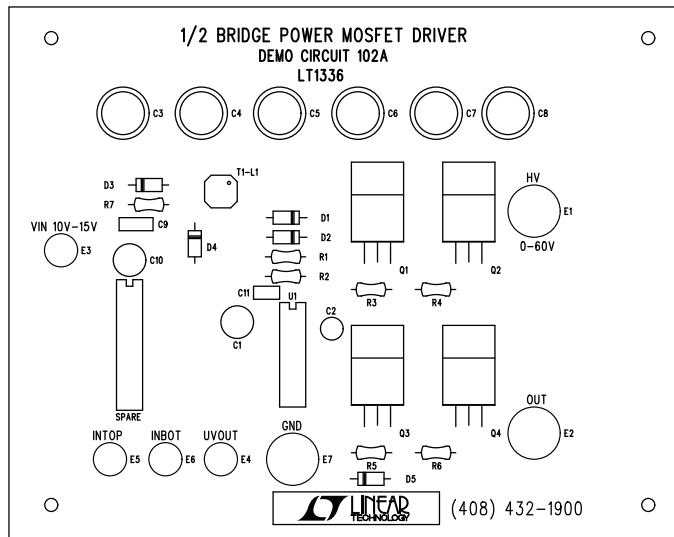

Component Side Silkscreen

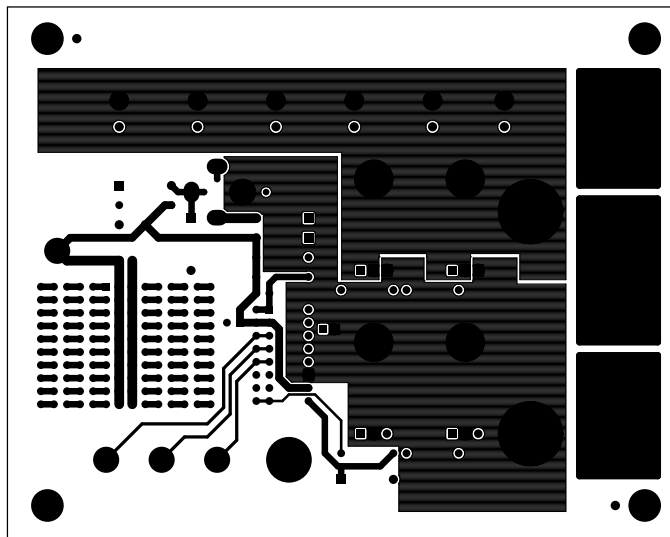

Component Side

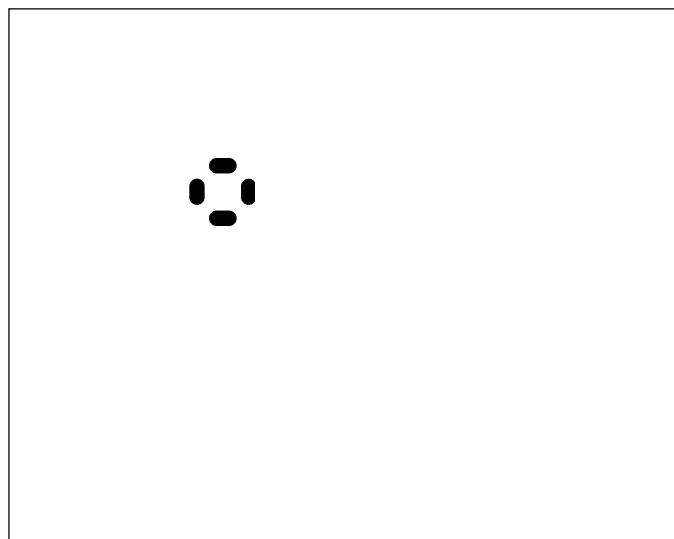

Component Side Pastemask

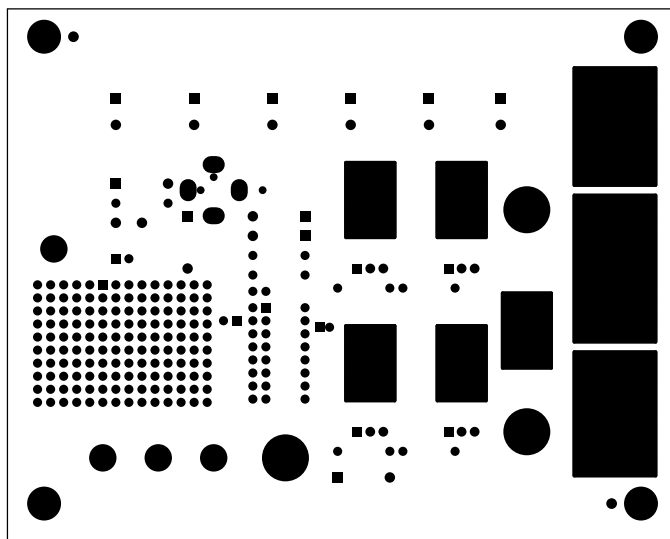

Component Side Solder Mask

PC LAYOUT AND FILM

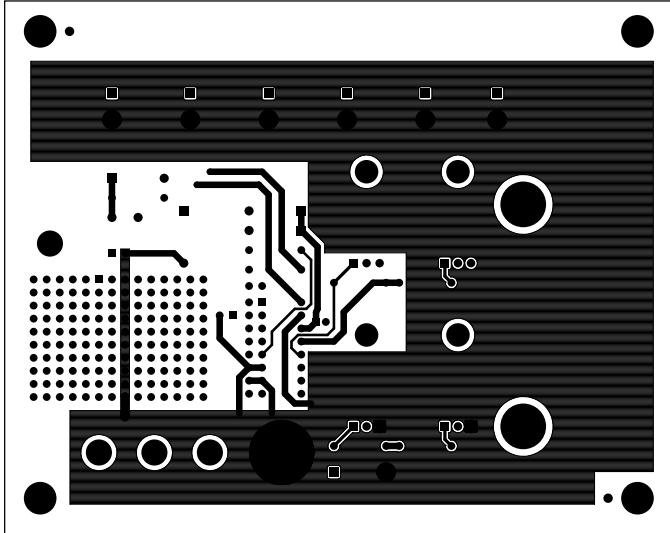

Solder Side

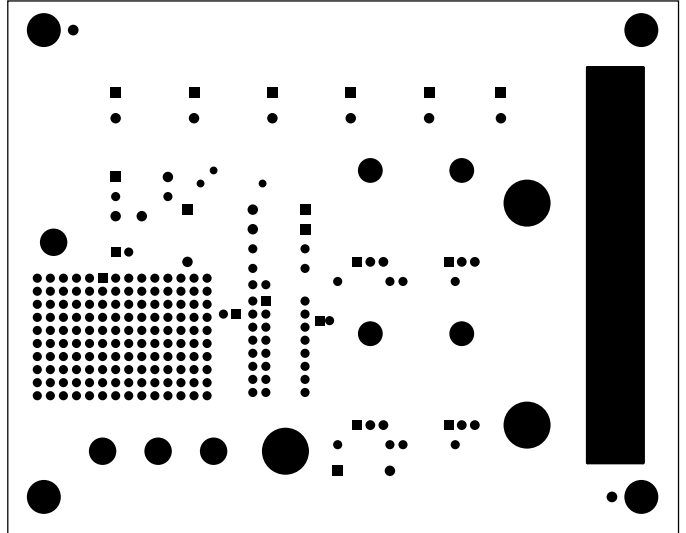

Solder Side Soldermask

DEMO MANUAL DC102

50V N-CHANNEL HALF BRIDGE

PC FAB DRAWING

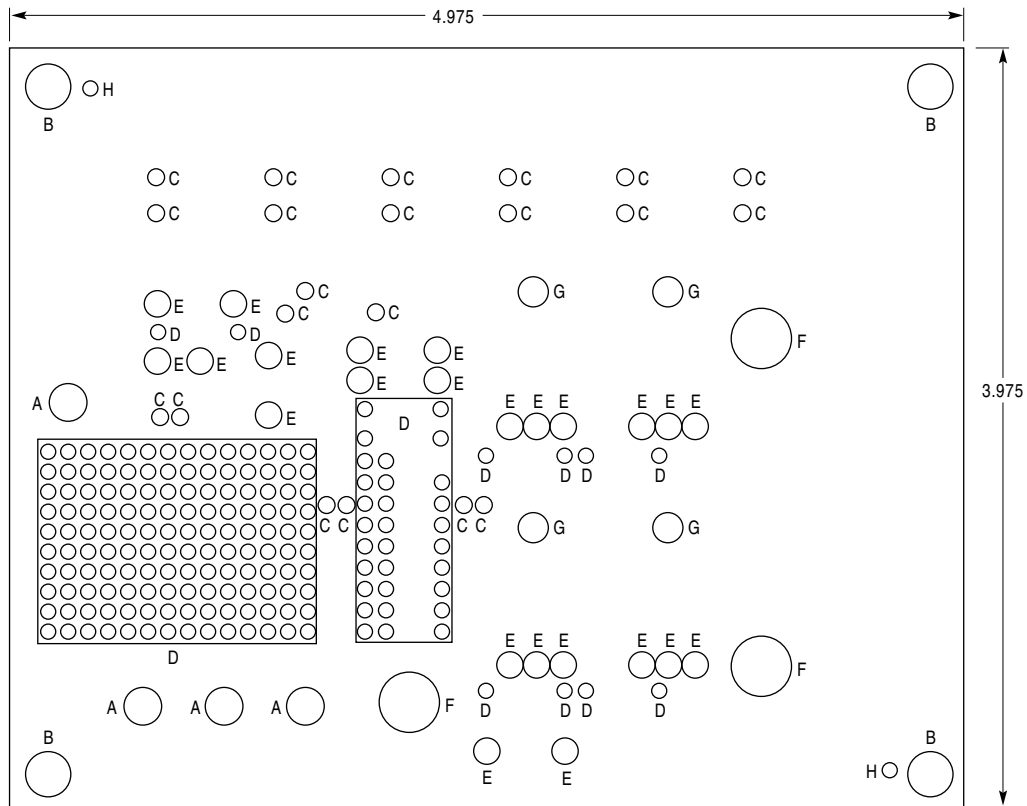

DM102A • PC FAB DWG

NOTES:

1. MATERIAL: FR4 OR EQUIVALENT EPOXY, 2 OZ COPPER CLAD THICKNESS 0.062 ±0.006 TOTAL OF 2 LAYERS
2. FINISH: ALL PLATED HOLES 0.001 MIN/0.0015 MAX COPPER PLATE ELECTRODEPOSITED TIN-LEAD COMPOSITION BEFORE REFLOW, SOLDER MASK OVER BARE COPPER (SMOBC)
3. SOLDER MASK: BOTH SIDES USING GREEN PC-401 OR EQUIVALENT
4. SILKSCREEN: USING WHITE NONCONDUCTIVE EPOXY INK
5. ALL DIMENSIONS ARE IN INCHES

SYMBOL	DIAMETER	NUMBER OF HOLES
A	0.095	4
B	0.125	4
C	0.028	21
D	0.032	180
E	0.040	24
F	0.205	3
G	0.156	4
H	0.072	2
TOTAL HOLES		242