



Chipsmall Limited consists of a professional team with an average of over 10 year of expertise in the distribution of electronic components. Based in Hongkong, we have already established firm and mutual-benefit business relationships with customers from,Europe,America and south Asia,supplying obsolete and hard-to-find components to meet their specific needs.

With the principle of “Quality Parts,Customers Priority,Honest Operation,and Considerate Service”,our business mainly focus on the distribution of electronic components. Line cards we deal with include Microchip,ALPS,ROHM,Xilinx,Pulse,ON,Everlight and Freescale. Main products comprise IC,Modules,Potentiometer,IC Socket,Relay,Connector.Our parts cover such applications as commercial,industrial, and automotives areas.

We are looking forward to setting up business relationship with you and hope to provide you with the best service and solution. Let us make a better world for our industry!



Contact us

Tel: +86-755-8981 8866 Fax: +86-755-8427 6832

Email & Skype: info@chipsmall.com Web: www.chipsmall.com

Address: A1208, Overseas Decoration Building, #122 Zhenhua RD., Futian, Shenzhen, China



High Voltage, High-Side Current Sense Amplifier in SOT-23

DESCRIPTION

Demonstration circuit 1115 is a General Purpose High-Side Current-Sense Amplifier featuring the LTC6101.

This demo board amplifies an on-board current-sense resistor voltage-drop, providing a precision uni-polar output voltage proportional to load current. The demo circuit includes scaling resistors that program the gain of the circuit to 25V/V. The LTC6101 is powered from the same supply that the sense resistor is connected to and provides a ground referenced output. The LTC6101 can perform current measurements on supplies ranging from 4V to 60V. Since the output voltage is developed as a controlled current through a load resistance, ground-loop errors can be eliminated by simply locating the load

resistor at the destination point (subsequent signal processing such as A/D conversion). Remote loading can be evaluated by simply removing the on board load resistor (R3).

The key performance characteristics of the LTC6101 and DC1115 are shown in the Performance Summary below.

Design files for this circuit board are available. Call the LTC factory.

LT, LT are registered trademarks of Linear Technology Corporation. Other product names may be trademarks of the companies that manufacture the products.

PERFORMANCE SUMMARY Specifications are at $T_R = 25^\circ\text{C}$

SYMBOL	PARAMETER	CONDITIONS	MIN	TYP	MAX	UNITS
V_{IN}	Monitored Supply Input Range		4	5...48	60	V
V_{MON}	Measurement Output Signal	$I_{OUT} = 5A$		2.5		V
I_{MON}	Measurement Output Signal (current mode)	$I_{OUT} = 5A$, R3 removed		500		μA
I_{OUT}	Output Load Current Range	Thermal limit of R_{SENSE}			7	A
I_{INQ}	V_{IN} Quiescent Current	$V_{IN} = 12V$, $I_{OUT} = 0A$		250		μA
t_R	V_{MON} step-response time	I_{OUT} step from 0A to 5A		2		μs

OPERATING PRINCIPLES

The LTC6101 operates by amplifying the voltage drop on a sense resistor placed in series with the power source of a load to be monitored. The sense inputs of the amplifier differentially measure the sense-resistor drop to control an internal variable current source that allows translation of the input information to a level referenced to $V-$ (ground in this demo circuit). The circuit gain is established by the ratio of the output resistor to the input

resistor and is essentially as accurate as the resistors used. In DC1115 as shipped, the sense resistor installed is 20m Ω and the resistor ratio sets the gain to 25V/V, so the nominal output scaling is 500mV per Ampere of load current. Other scalings can be produced by resistor replacement on the demo circuit.

The DC1115 Schematic diagram is shown in Figure 2.

QUICK START PROCEDURE

Demonstration circuit 1115 is easy to set up to evaluate the performance of the LTC6101. Refer to Figure 1 for proper measurement equipment setup and follow the procedure below:

1. With power off, connect the power supply positive to IN and the common to GND. This supply should be in the range of 4V to 60V. If this supply is not equipped with an accurate current readout, a DMM (set to measure Amperes) may be connected in series with the supply as shown in Figure 1.

NOTE. Be sure that the current capacity of the DMM is adequate to handle the intended load current.

2. Connect a voltmeter or oscilloscope probe to the MON terminal, with the common connection or ground clip tied to GND.
3. Connect a load to the OUT terminal (positive) and return (negative) to the common of the power supply. The load may be a power resistor, active load instrument, or other circuit of interest.
4. Turn on the power supply.
5. Measure an output voltage that corresponds to the load current. $V_{MON} = 0.5 \times I_{OUT}$ for the factory installed resistors.

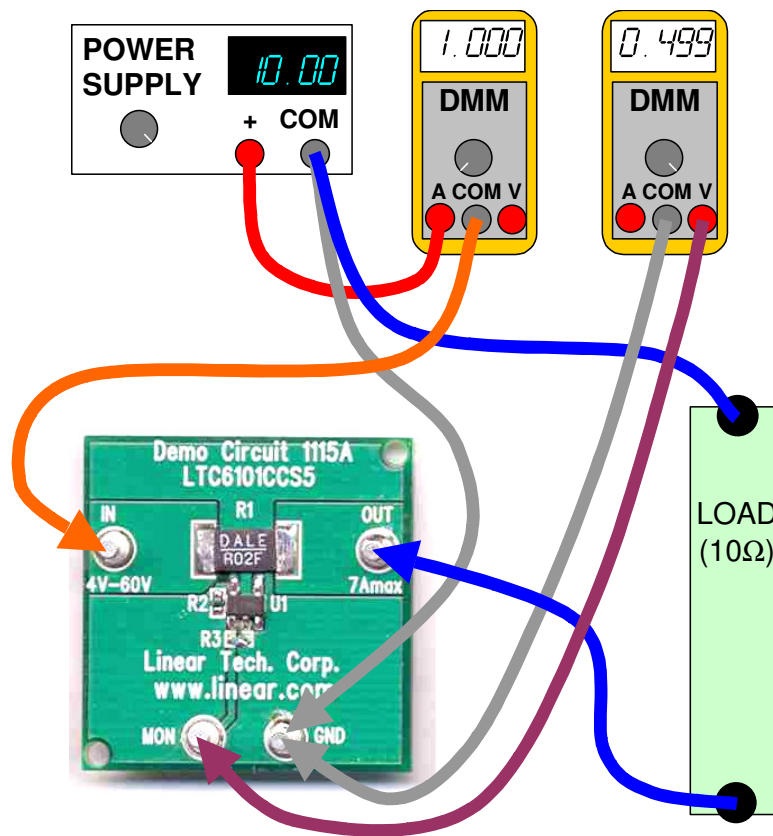

Figure 1. Proper Measurement Equipment Setup

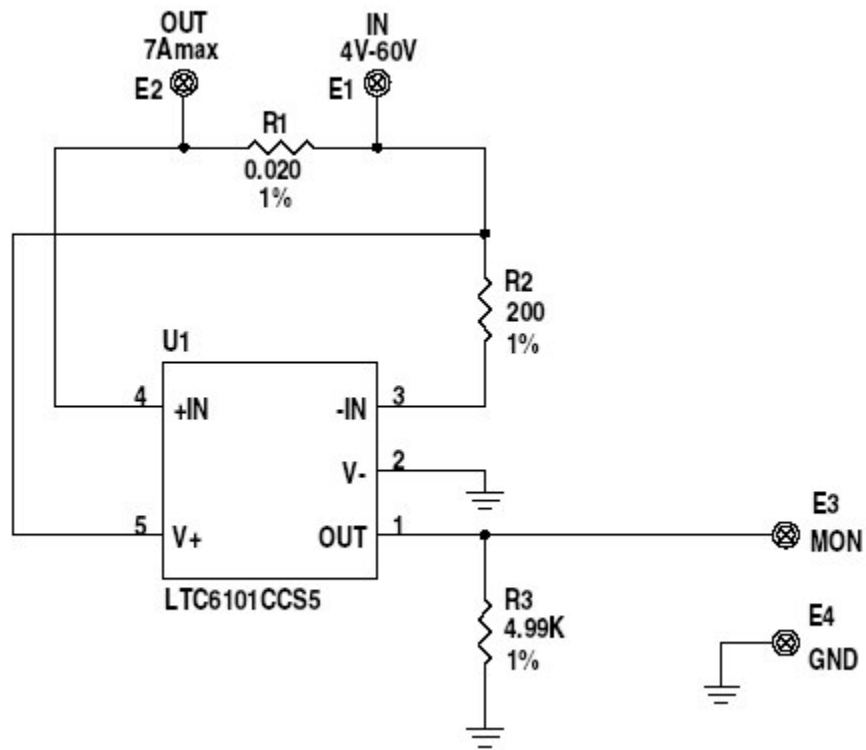

Figure 2. DC1115 Schematic Diagram