



Chipsmall Limited consists of a professional team with an average of over 10 year of expertise in the distribution of electronic components. Based in Hongkong, we have already established firm and mutual-benefit business relationships with customers from,Europe,America and south Asia,supplying obsolete and hard-to-find components to meet their specific needs.

With the principle of “Quality Parts,Customers Priority,Honest Operation,and Considerate Service”,our business mainly focus on the distribution of electronic components. Line cards we deal with include Microchip,ALPS,ROHM,Xilinx,Pulse,ON,Everlight and Freescale. Main products comprise IC,Modules,Potentiometer,IC Socket,Relay,Connector.Our parts cover such applications as commercial,industrial, and automotives areas.

We are looking forward to setting up business relationship with you and hope to provide you with the best service and solution. Let us make a better world for our industry!



## Contact us

Tel: +86-755-8981 8866 Fax: +86-755-8427 6832

Email & Skype: info@chipsmall.com Web: www.chipsmall.com

Address: A1208, Overseas Decoration Building, #122 Zhenhua RD., Futian, Shenzhen, China



## LED Driver with One Wire Control and Output Disconnect

**WARNING!**

DO NOT LOOK AT OPERATING LED.  
 This circuit produces light that can damage eyes.

### DESCRIPTION

Demonstration circuit 1224 is a LED Driver with One Wire Control and Output Disconnect featuring the LT3593. The LT3593 is a step-up current mode DC/DC converter designed to drive up to 10 white LEDs in series from a Li-Ion cell. The demo board has two sections. The top section showcases the small size LED drive. The maximum current is 20mA. The bottom section is the control section that generates pulses for the CTRL pin of the LED driver. The number of pulses and its timing determine the current and brightness of the LEDs.

The LCD display in the bottom section shows the status of the commanding LED current level in the format as "LEVEL=value" and LED current level as "ILED=value". The LEVEL value responds to the UP button SW1 and DOWN button SW2 immedi-

ately. The ILED value only changes to the commanding LEVEL value after the SEND/STORE button SW3 is pushed. Pushing SEND/STORE button also save the LEVEL value in the memory of the micro-controller U2 as the default LED current level.

The LT3593 datasheet gives complete description of the part, operation and application information. The datasheet must be read in conjunction with this quick start guide for working on or modifying the demo circuit 1224.

**Design files for this circuit board are available. Call the LTC factory.**

LTC, LTC and LT are registered trademarks of Linear Technology Corporation. ThinSOT and PowerPath are trademarks of Linear Technology Corporation.

### PERFORMANCE SUMMARY

Specifications are at  $T_A = 25^\circ\text{C}$

SYMBOL	PARAMETER	CONDITIONS	MIN	TYP	MAX	UNITS
$V_{IN}$	Input Supply Range		3		5	V
+5V	Input Supply for Control Section		4.5	5	5.5	V
$I_{LED\ MAX}$	Maximum Output LED Current		19	20	21	mA
$V_{OUT\ MAX}$	Maximum Output Voltage				40	V
$\eta$	Efficiency	$V_{IN}=5V$ , 8 White LEDs $V_{IN}=3.6V$ , 8 White LEDs		81 79		%
$V_{OPEN}$	Over voltage Protection	LED Open	36	38	40	V
$F_s$	Switching Frequency		0.85	1	1.15	MHz

## QUICK START PROCEDURE

Demonstration circuit 1224 is easy to set up to evaluate the performance of the LT3593. Refer to Figure 1 for proper measurement equipment setup and follow the procedure below:

1. Place jumpers in the following positions:

### JP1 PIC

2. With power off, connect a 3V to 5V power supply to  $V_{IN}$  and GND.
3. With power off, connect 4.5V to 5.5V power supply to +5V and GND.
4. Connect a string of up to 10 LEDs between LED+ and LED-. The Cathode of the last LED connects to the LED-.

5. Turn on the power at the input.

NOTE . Make sure that the input voltage does not exceed 5V.

6. Turn on the power at +5V.

7. Check for the proper voltages and currents.

NOTE . By default of the demo board, the current is 20mA when power is applied the very first time.

8. Adjust the UP (SW1), DOWN (SW2), SEND/STORE (SW3) to the value of interest between 0 and 32, where  $I_{LED}=32$  gives 20mA,  $I_{LED}=1$  gives 625uA, and  $I_{LED}=0$  shuts down the part.

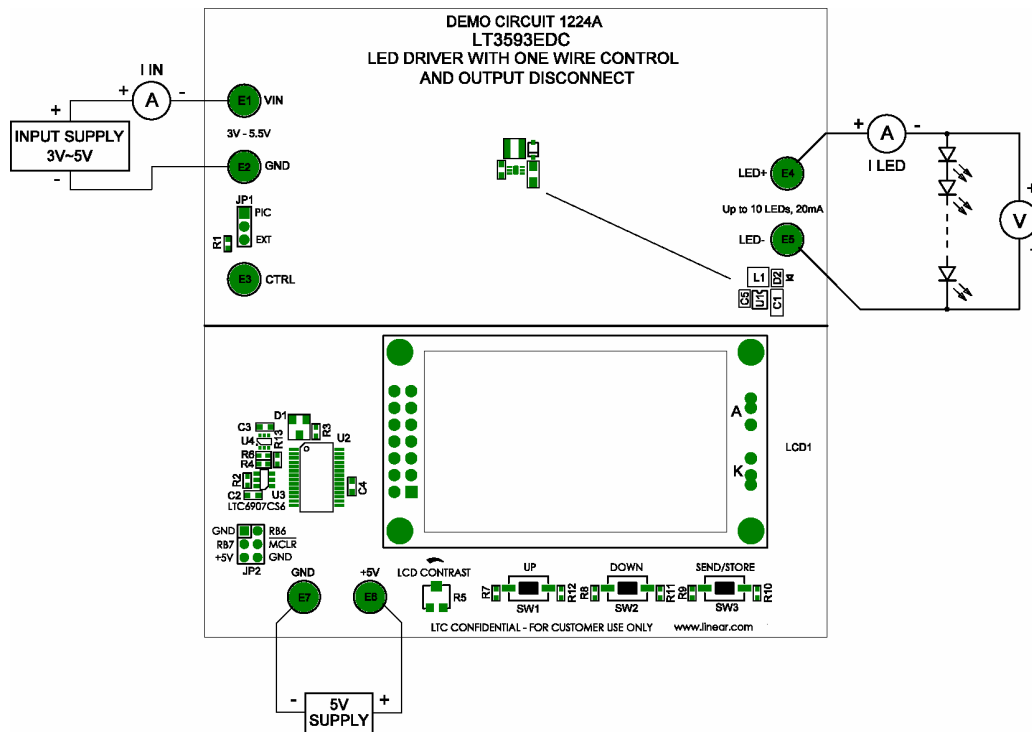
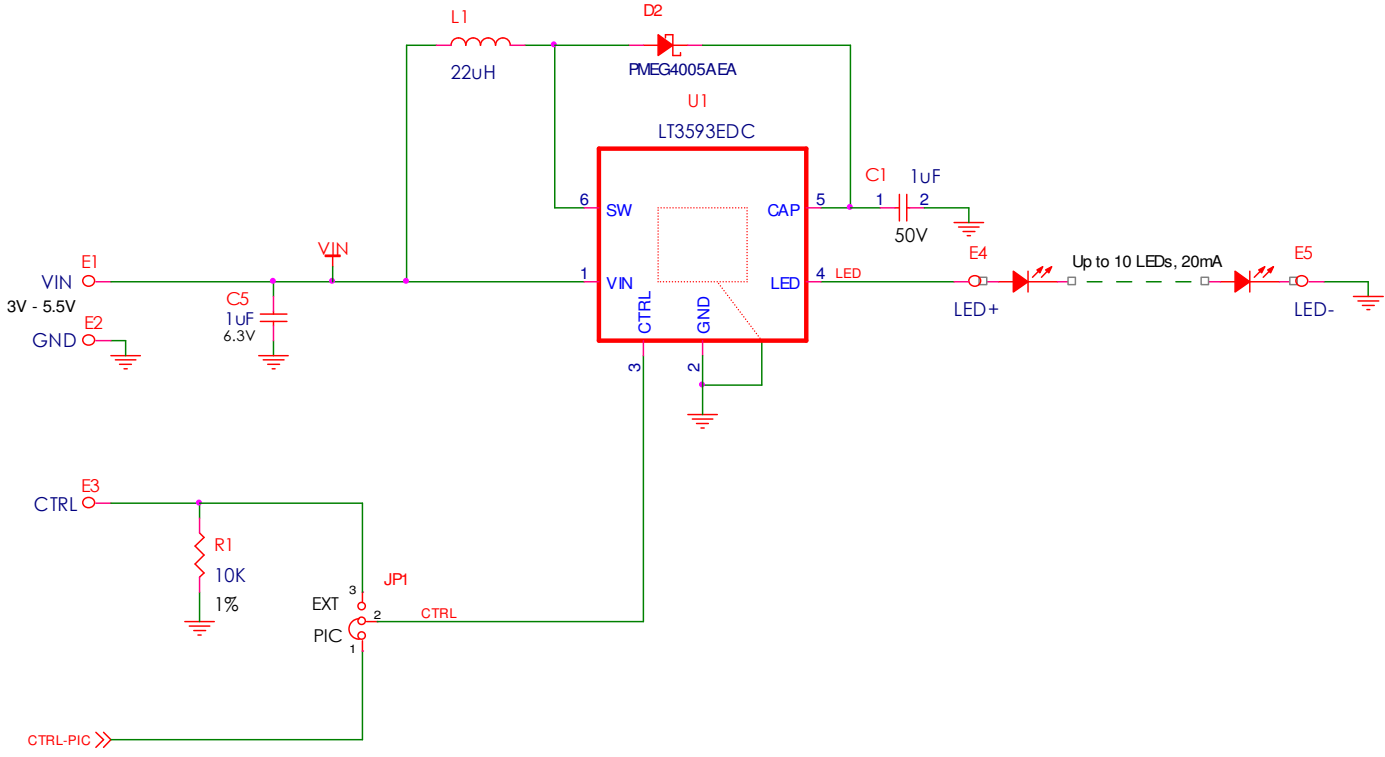

Figure 1. Proper Measurement Equipment Setup





Item	Qty	Reference	Part Description	Manufacturer's Part Number
<b>REQUIRED CIRCUIT COMPONENTS:</b>				
1	1	C1	CAP, 0805 1uF 10% 50V X7R	MURATA GRM21BR71H105K
2	1	C5	CAP, 0603 1uF 20% 6.3V X5R	AVX 06036D105MAT
3	1	D2	DIODE, SCHOTTKY	PHILIPS PMEG4005AEA
4	1	L1	INDUCTOR, 22uH	TAIYO YUDEN NR3015T220M
5	1	U1	IC, LT3593EDC	LINEAR TECH. LT3593EDC#PBF
<b>ADDITIONAL DEMO BOARD CIRCUIT COMPONENTS:</b>				
1	1	C2	CAP, 0603 1uF 20% 10V X5R	AVX 0603ZD105MAT
2	2	C3, C4	CAP, 0603 0.1uF 10% 50V X7R	AVX 06035C104KAT
3	1	D1	DIODE, SCHOTTKY	ZETEX BAT54C
4	1	LCD1	IC, LCD, NO BACKLIGHT	CRYSTALFONTZ AMERICA CFAH0902A-NYA-JP
5	7	R1,R3,R6,R7,R8,R9,R13	RES, 0402 10K OHM 1% 1/16W	VISHAY CRCW040210K0FKED
6	1	R2	RES, 0402 100 OHMS 1% 1/16W	VISHAY CRCW0402100RFKED
7	1	R4	RES, 0402 49.9K OHMS 1% 1/16W	VISHAY CRCW040249K9FKEA
8	1	R5	RES, 10K POT	PANASONIC EVM-3YSX50B14
9	3	R10,R11,R12	RES, 0402 100K OHMS 1% 1/16W	VISHAY CRCW0402100KFKEE
10	1	U2	IC, MICRO CONTROLLER	MICROCHIP PIC16F873A-I/SS
11	1	U3	IC, RESISTOR SET OSC	LINEAR TECH LTC6907CS6
12	1	U4	IC, UHS DUAL BUFFER	FAIRCHILD NC7WZ17P6X
<b>HARDWARE-FOR DEMO BOARD ONLY:</b>				
1	7	E1-E7	TURRET	MILL-MAX 2501-2-00-80-00-00-07-0
2	1	JP1	HEADER, 3PIN, 2mm	SAMTEC TMMF-103-02-L-S
3	1	JP2	HEADER, 2X3, 2mm	SAMTEC TMM-103-02-L-D
4	3	SW1,SW2,SW3	SWITCH, MOMENTARY	PANASONIC EVOPPPA25
5	1	XJP1	SHUNT, 2mm	SAMTEC 2SN-BK-G
6	4	MTGS AT 4 CORNERS	STAND OFF	KEYSTONE 8831
7	1	XLCD1	Headers, Dbl, Row 2 x 7 0.1" ctrs.	Samtec TSW-107-07-L-D
8	2	XLCD1	Headers, SINGLE Row 2 x 1 0.1" ctrs.	Samtec TSW-101-07-L-S