



Chipsmall Limited consists of a professional team with an average of over 10 year of expertise in the distribution of electronic components. Based in Hongkong, we have already established firm and mutual-benefit business relationships with customers from,Europe,America and south Asia,supplying obsolete and hard-to-find components to meet their specific needs.

With the principle of “Quality Parts,Customers Priority,Honest Operation,and Considerate Service”,our business mainly focus on the distribution of electronic components. Line cards we deal with include Microchip,ALPS,ROHM,Xilinx,Pulse,ON,Everlight and Freescale. Main products comprise IC,Modules,Potentiometer,IC Socket,Relay,Connector.Our parts cover such applications as commercial,industrial, and automotives areas.

We are looking forward to setting up business relationship with you and hope to provide you with the best service and solution. Let us make a better world for our industry!



Contact us

Tel: +86-755-8981 8866 Fax: +86-755-8427 6832

Email & Skype: info@chipsmall.com Web: www.chipsmall.com

Address: A1208, Overseas Decoration Building, #122 Zhenhua RD., Futian, Shenzhen, China



LTC3220/LTC3220-1 360mA Universal 18-Channel LED Driver

DESCRIPTION

WARNING!

Do not look directly at operating LED.

This circuit produces light that can damage eyes.

Demonstration circuit 1265 is a 360mA Universal 18-Channel LED Driver with twelve white LEDs and two RGB LEDs featuring the LTC3220/LTC3220-1.

The LTC3220/LTC3220-1 is a low noise charge pump designed to drive 18 universal LED (ULED) current sources. The LTC3220/LTC3220-1 requires only five small ceramic capacitors to form a complete LED power supply and current controller.

The maximum display currents are set with an internal precision current reference. On/Off blinking, gradation, intensity, and a software controlled shutdown are ac-

complished via an I²C serial interface. See the LTC3220/LTC3220-1 data sheet for more information on this process. There are 64 dimming states available for the universal LEDs.

The charge pump optimizes efficiency based on the voltage across the LED current sources. The part powers up in 1x mode and will automatically switch to boost mode whenever any enabled LED current source begins to drop out. The first dropout switches the part to 1.5x mode and a subsequent dropout switches the part into 2x mode. The part resets to 1x mode whenever a data byte is updated via the I²C port.

Design files for this circuit board are available. Call the LTC factory.

LT, LTC, LTM, LT are registered trademarks of Linear Technology Corporation. Other product names may be trademarks of the companies that manufacture the products.

PERFORMANCE SUMMARY Specifications are at T_A = 25°C

PARAMETER	CONDITIONS	MIN	TYP	MAX	UNITS
Input Supply Range (V _{IN})		2.9		5.5	V
VIN Shutdown Current			3.2	7	µA
DV _{CC} Operating Voltage		1.5		5.5	V
DV _{CC} Shutdown Current				1	µA
CPO Regulation Voltage	1.5x Mode, I _{CPO} = 20mA		4.5		V
	2x Mode, I _{CPO} = 20mA		5.03		V
Full-Scale LED Current	ULED = 1V	18	20	22	mA
Absolute Maximum LED Current	Strong GPO Mode, external current limit needed			25	mA
Minimum (I _{LSB}) LED Current Step			0.314		mA
Minimum Programmable Current	ULED Data Register Programmed to 0b00000001		0.395		mA
LED Current Matching	Any Two Outputs, 50% Full-Scale		1.5		%
LED Dropout Voltage	I _{LED} = Full-Scale		120		mV
LED Turn-on Delay	From Stop Bit, Part Enabled		4		µS

QUICK START PROCEDURE

Demonstration circuit 1265 is easy to set up to evaluate the performance of the LTC3220/LTC3220-1. Refer to Figure 1 for proper measurement equipment setup and follow the procedure below:

NOTE. When measuring the input or output voltage ripple, care must be taken to avoid a long ground lead on the oscilloscope probe. Measure the input or output voltage ripple by touching the probe tip directly across the VIN and GND or CPO and GND terminals. See Figure 2 for proper scope probe technique.

1. Refer to the DC590 Quick Start Guide for QuikEval™ setup and software installation details.
2. Make sure the USB cable is connected between the computer and the DC590 controller board.

NOTE. If using the DC590B board, a specific DVCC voltage level may be selected. This is done by setting the VCCIO jumper on the DC590 board to one of the following settings: 3.3V, 5V, removed for 2.7V or set to external if an external supply is desired to be used.

3. Connect DC1265 to the DC590 USB Serial Controller using the supplied 14-conductor ribbon cable as shown in Figure 1.
4. With power off, connect a 5V, 1A power supply to VIN and GND with a series ammeter and a voltmeter as shown in Figure 1.
5. Turn on and set the input power supply between 2.9 – 5.5V. The DC1265 has an extra 4.7uF de-coupling capacitor between VIN and GND to help accommodate long VIN source lead lengths. The DC590 board gets its power from the USB cable.
NOTE. Make sure that the input voltage does not exceed 6V.
6. Run the QuikEval program. The program detects the DC1265 and displays the LTC3220 control window (shown in Figure 5).

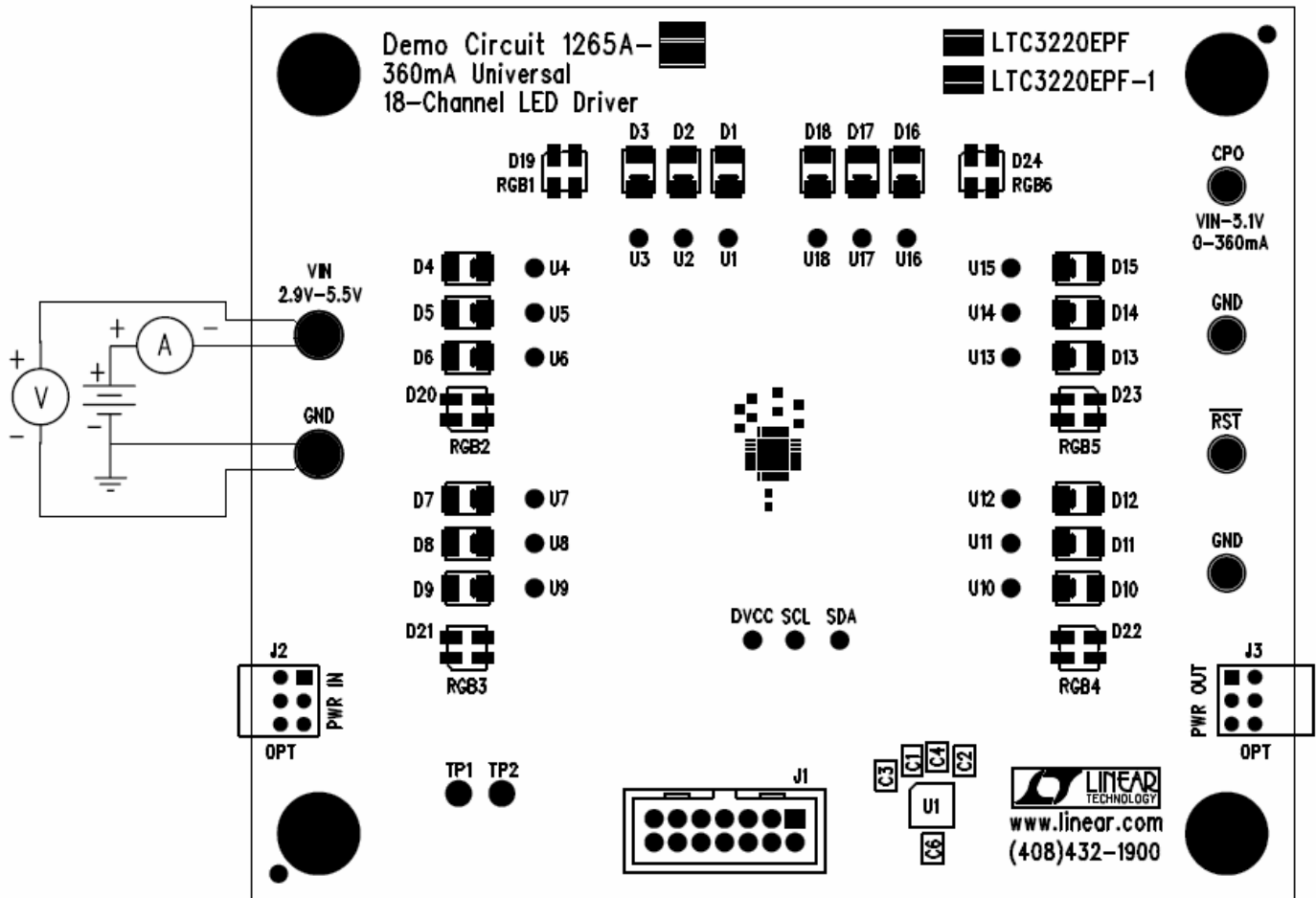

Figure 1. Proper Measurement Equipment Setup

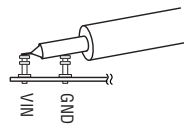

Figure 2. Measuring Input or Output Ripple

USING THE LTC3220 QUIKEVAL SOFTWARE

The LTC3220 program provides brightness controls, allows the user to gradate the LEDs up or down, and blink at a selected on-time and period. A software controlled shutdown bit allows the user to go into shutdown and return to the previous state at any time. The LTC3220/LTC3220-1 also has an external reset pin which resets all the internal registers and puts the part into shutdown. The intensity of the LEDs may be set by selecting the AUTO SET ULEDs button (green when selected) and then setting the intensity in the associated vertical slider.

LTC3220/LTC3220-1 select button selects between the LTC3220 and the LTC3220-1 I²C address to drive demo boards with either the LTC3220 (DC1265A-A) or the LTC3220-1 (DC1265A-B). If the button is not selected to the correct address and an Acknowledge is not received, an Error message box pops up as shown in Figure 3. Select OK to return to the program to correct the problem or select Cancel to quit the program.

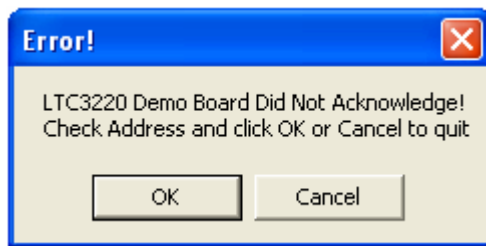

Figure 3. Acknowledge not received Error Message Box

VIEW LTC3220 PRODUCT PAGE button opens an internet browser and searches the Linear Technology Corporation web site for information on the LTC3220 when an internet connection is available.

REG0 through **REG19** text box windows display the hexadecimal value that has been written to the corresponding registers of the selected LTC3220/LTC3220-1. These values are updated when the LTC3220/LTC3220-1 button is selected to show what was written last to the associated part.

U1 through **U18** select buttons (located above the vertical sliders) are used to individually select or deselect the modes or intensity of the ULED outputs.

U1 through **U18** vertical sliders control the intensity for associated ULED outputs from 0 to 20mA in 64 steps when the AUTO SET ULEDs button is active or when the SET SELECTED ULEDs, BLINK ULEDs, or other ULED control buttons are selected. The ULED intensity slider may be adjusted by clicking on the up or down arrows to increment or decrement by one LSB or by clicking and dragging the slide pointer. The hex code is displayed in the box below the slider.

SET SELECTED ULEDs button sets all selected LEDs to the chosen intensity settings.

AUTO SET ULEDs button is green when activated. When a ULED vertical slider is changed while this button is activated, the associated LED immediately updates. When this button is not activated (yellow), the SET SELECTED ULEDs, BLINK ULEDs, GPO MODE, or one of the gradation buttons must be used to set or change the LED intensity.

SELECT ALL selects all ULED outputs to change when the SET SELECTED ULEDs, CLEAR SELECTED ULEDs, or other ULED control buttons are selected.

DESELECT ALL deselects all selected ULED outputs and prevents the ULED outputs from changing intensity or modes when the SET SELECTED ULEDs, CLEAR SELECTED ULEDs, or other ULED control buttons are selected. The ULED intensity will still change when the AUTO SET ULEDs button is activated.

QUICK WRITE button uses the LTC3220/LTC3220-1 Quick Write feature to set all LEDs to the same intensity and mode as ULED1. The intensity of ULED1 is updated to the value indicated on the U1 vertical slider. All vertical sliders and register text boxes on the LTC3220 Control Window are updated to match the IC settings. The U1 select button does not need to be selected for this button to work.

INTENSITY TRACKING button adjusts the vertical sliders U2-U18 to the same setting as vertical slider U1 when the U1 vertical slider is changed with the Intensity Tracking button is selected.

CLEAR SELECTED ULEDs button turns off and clears the register for all selected ULED outputs.

GRADATION TIME option buttons set the desired time to gradate up to or down from the selected ULED intensity when the GRADATE UP or GRADATE DOWN buttons are selected. If the DISABLED option button is selected, the ULED outputs will not gradate when any of the GRADATION control buttons are selected.

GRADATE UP button gradates the selected ULED outputs up to the desired intensity and disables gradation when done. The associated ULED select button above the vertical slider is highlighted purple to indicate that gradation mode has been enabled.

GRADATE DOWN button gradates the selected ULED outputs down from the set intensity and disables gradation when done. The associated ULED select button above the vertical slider is highlighted purple to indicate that gradation mode has been enabled.

BLINK ONT/PERIOD option buttons set the desired blinking on-time and period to blink after the BLINK ULEDs button has been selected.

BLINK ULEDs button blinks or stops blinking the selected ULED outputs at the on-time and period selected by the BLINK ONT/PERIOD option buttons and at the selected ULED intensity. The associated ULED select button above the vertical slider is highlighted green to indicate that blink mode has been enabled.

CHARGE PUMP MODE option buttons allow the user to select between Auto switching (not forced to any mode), Force 1x, Force 1.5x, and Force 2x charge pump modes.

GPO MODE button disables or enables dropout for the selected ULED outputs. When dropout is disabled the ULED output will not cause the charge pump to switch into 1.5x or 2x modes and the pin may be used as a general-purpose output (GPO).

When GPO mode is initiated with a ULED intensity value greater than 0, then the Current Limited GPO Mode is set. The GPO is current limited to the current set with the associated vertical slider. The associated ULED select button above the vertical slider is highlighted orange to indicate that GPO mode has been initiated.

If GPO is initiated with the ULED intensity set to 0, then the Strong Pull-Down GPO Mode is set. The Strong Pull-Down mode is not current limited and only consumes 3uA of quiescent current per GPO. When this mode is invoked a pop-up window warns the user that a current limit resistor is needed to prevent the current from exceeding 25mA as shown in Figure 4. Select OK to continue into Strong GPO Mode or Cancel to return to the program without setting the ULED output to Strong GPO Mode.

NOTE. When Strong GPO mode is used, the LED should be removed and a current limiting resistor should be installed to make sure that the current does not exceed the Absolute Maximum rated current. Since CPO is limited by a weak pull-up during shutdown, CPO should not be used as source to any output in Strong GPO mode during shutdown.

Figure 4. Strong GPO Mode Warning Message Box

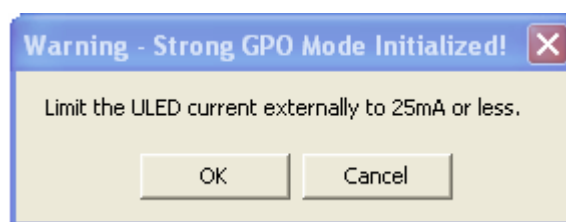

UPDATE ALL REG button updates the data registers to the data displayed in the register text boxes.

/RESET button resets all internal registers using the external /RST pin when this button is not set (red). When this button is set (green) then the /RESET button is set to DVCC.

SHUTDOWN button, when set (red), sets the SHUTDOWN bit in the command register and puts the LTC3220 into shutdown. When this button is not set (green), it clears the SHUTDOWN bit in the command register and the LTC3220 returns to its previous state.

DEMO 1 button may be selected to start or stop Demo 1. Demo 1 cycles through some of the colors that the RGB LEDs can produce using the LTC3220/LTC3220-1's gradation feature. Once the RGB color demo is complete, the demo then blinks the two RGB LEDs and gradates up the white LEDs two at a time. Then all LEDs are set to blink together using the Quick Write feature. Lastly, all LEDs are gradated up and down together prior to repeating the entire sequence.

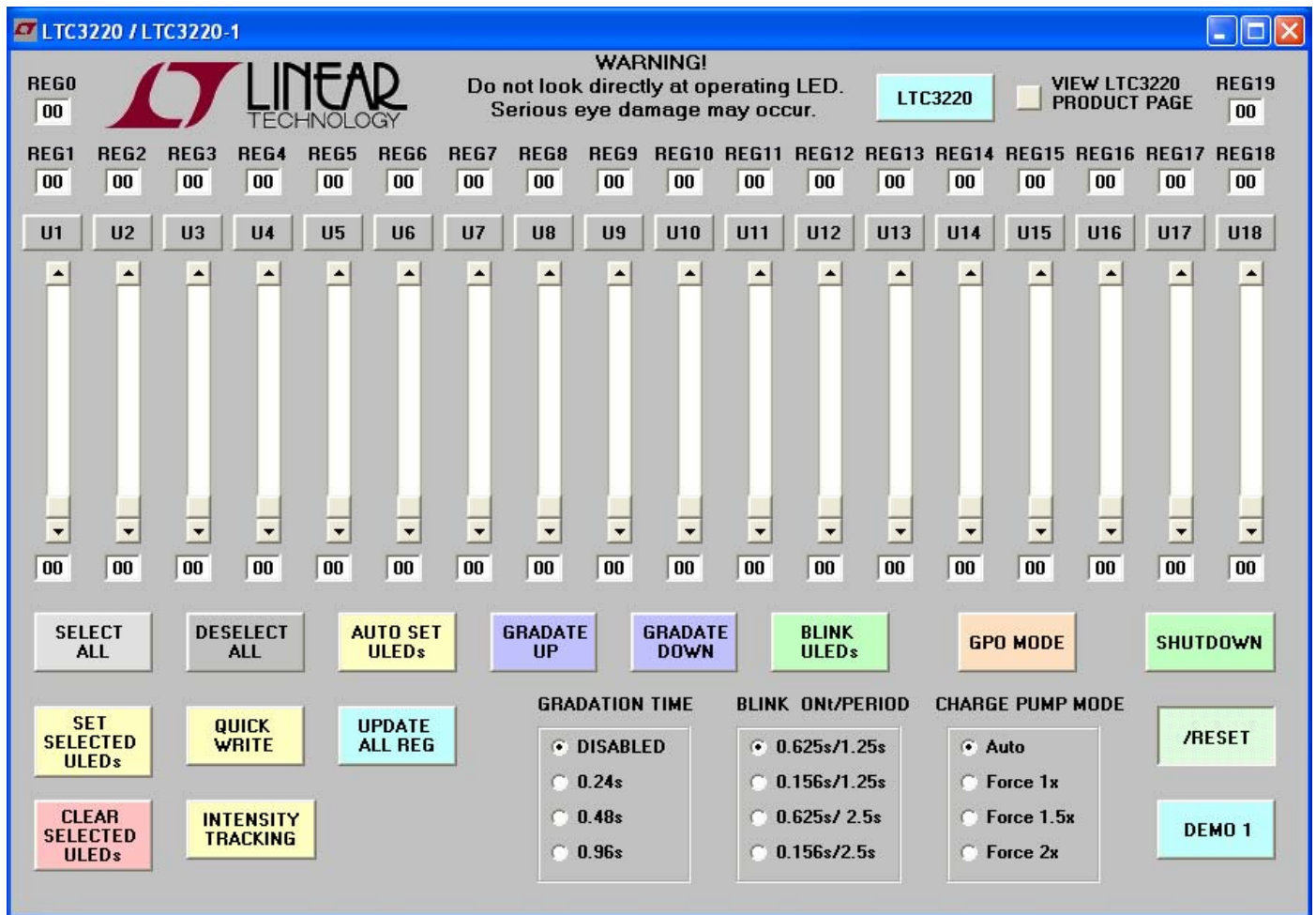
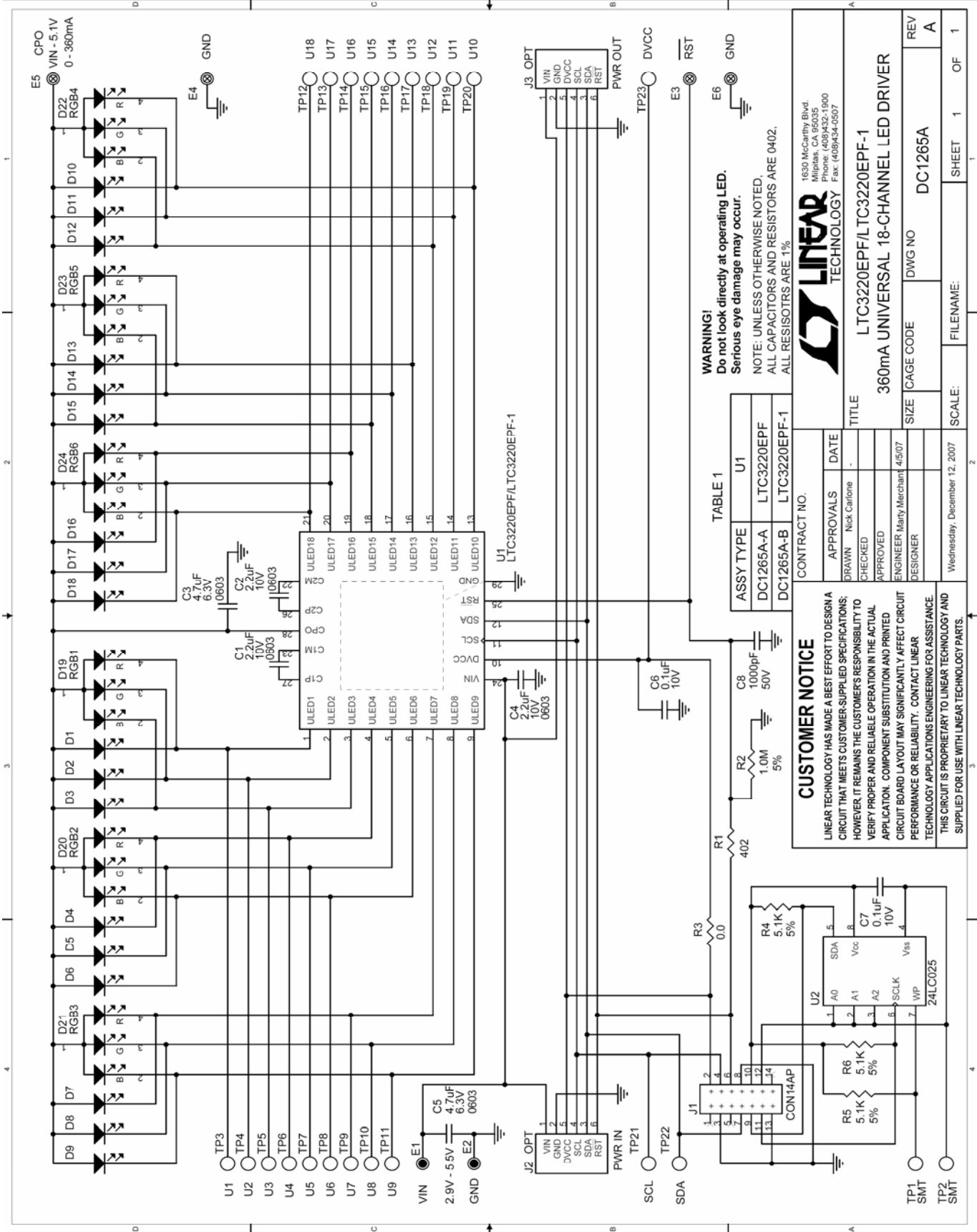

Figure 5. LTC3220 Control Window



WARNING!
Do not look directly at operating LED.
Serious eye damage may occur.

NOTE: UNLESS OTHERWISE NOTED,
ALL CAPACITORS AND RESISTORS ARE 0402.
ALL RESISTORS ARE 1%

TABLE 1

ASSY TYPE	U1
DC1265A-A	LTC3220EPF
DC1265A-B	LTC3220EPF-1

CUSTOMER NOTICE
 LINEAR TECHNOLOGY HAS MADE A BEST EFFORT TO DESIGN A CIRCUIT THAT MEETS CUSTOMER-SUPPLIED SPECIFICATIONS; HOWEVER, IT REMAINS THE CUSTOMER'S RESPONSIBILITY TO VERIFY PROPER AND RELIABLE OPERATION IN THE ACTUAL APPLICATION. COMPONENT SUBSTITUTION AND PRINTED CIRCUIT BOARD LAYOUT MAY SIGNIFICANTLY AFFECT CIRCUIT PERFORMANCE OR RELIABILITY. CONTACT LINEAR TECHNOLOGY APPLICATIONS ENGINEERING FOR ASSISTANCE. THIS CIRCUIT IS PROPRIETARY TO LINEAR TECHNOLOGY AND SUPPLIED FOR USE WITH LINEAR TECHNOLOGY PARTS.

CONTRACT NO.

APPROVALS	DATE
DRAWN Nick Carlone	
CHECKED	
APPROVED	
ENGINEER Marty Merchant	4/5/07
DESIGNER	

TITLE
LTC3220EPF/LTC3220EPF-1
360mA UNIVERSAL 18-CHANNEL LED DRIVER

SIZE CAGE CODE **DWG NO** DC1265A **REV** A

SCALE: **FILENAME:** **SHEET** 1 **OF** 1

Wednesday, December 12, 2007

LINEAR TECHNOLOGY
 1630 McCarthy Blvd.
 Milpitas, CA 95035
 Phone: (408)432-1900
 Fax: (408)434-0507

LTC 3220/ LTC 3220-1

Linear Technology Corporation
LTC3220EPF

Parts List

Demo Circuit 1265A-A
1/2/2008

Item	Qty	Ref - Des	Desc	Manufacturer's Part Number
REQUIRED CIRCUIT COMPONENTS:				
1	3	C1,C2,C4	CAP, X5R 2.2uF 10V 10% 0603	MURATA, GRM188R61A225KE34D
2	1	C3	CAP, X5R 4.7uF 6.3V 10% 0603	TDK, C1608X5R0J475K
3	1	C6	CAP, X5R 0.1uF 10V 10% 0402	MURATA, GRM155R61A104KA01
4	12	D4-D15	LED, SMT WHITE	NICHIA, NSSW100CT
5	2	D19,D24	LED, SMT RGB	NICHIA, NSCM315CT
6	1	U1	IC, 360mA UNIVERSAL MULTI-OUTPUT LED	LINEAR TECH., LTC3220EPF
ADDITIONAL DEMO BOARD CIRCUIT COMPONENTS:				
1	1	C5	CAP, X5R 4.7uF 6.3V 10% 0603	TDK, C1608X5R0J475K
2	1	C7	CAP, X5R 0.1uF 10V 10% 0402	MURATA, GRM155R61A104KA01
3	1	C8	CAP, X7R 1000pF 50V 10% 0402	AVX, 04025C102KAT
4	1	R1	RES, 402 OHMS 1% 1/16W 0402	VISHAY, CRCW0402402RFKED
5	1	R2	RES, 1.0M OHMS 5% 1/16W 0402	VISHAY, CRCW04021M00JNED
6	1	R3	RES, 0 OHMS 1/16W 0402	VISHAY, CRCW04020000Z0ED
7	3	R4,R5,R6	RES, 5.1K OHMS 5% 1/16W 0402	VISHAY, CRCW04025K10JNED
8	0	D1-D3, D16-D18 (OPT)	LED, SMT WHITE	NICHIA, NSSW100CT
9	0	D20-D23 (OPT)	LED, SMT RGB	NICHIA, NSCM315CT
10	0	U2	IC, SERIAL EEPROM	MICROCHIP, 24LC025-I/ST
HARDWARE FOR DEMO BOARD ONLY:				
1	1	J1	HEADER, 2X7 2MM STRAIGHT	MOLEX/WALDOM, 87831-1420
2	0	J2 (OPT)	HEADER, 2X6 2MM R/A	
3	0	J3 (OPT)	SOCKET, 2X6 2MM R/A	
4	4	E3-E6	TURRET, TESTPOINT	MILL-MAX, 2308-02
5	2	E1,E2	TURRET, TESTPOINT	MILL-MAX, 2501-02
6	4		STANDOFFS	KEYSTONE, 8831
7	1		CABLE ASSY., 8" STRIP	LINEAR RIBBON CABLE, CA-2440

Linear Technology Corporation
LTC3220EPF-1

Parts List

Demo Circuit 1265A-B
1/2/2008

Item	Qty	Ref - Des	Desc	Manufacturer's Part Number
REQUIRED CIRCUIT COMPONENTS:				
1	3	C1,C2,C4	CAP, X5R 2.2uF 10V 10% 0603	MURATA, GRM188R61A225KE34D
2	1	C3	CAP, X5R 4.7uF 6.3V 10% 0603	TDK, C1608X5R0J475K
3	1	C6	CAP, X5R 0.1uF 10V 10% 0402	MURATA, GRM155R61A104KA01
4	12	D4-D15	LED, SMT WHITE	NICHIA, NSSW100CT
5	2	D19,D24	LED, SMT RGB	NICHIA, NSCM315CT
6	1	U1	IC, 360mA UNIVERSAL MULTI-OUTPUT LED	LINEAR TECH., LTC3220EPF-1
ADDITIONAL DEMO BOARD CIRCUIT COMPONENTS:				
1	1	C5	CAP, X5R 4.7uF 6.3V 10% 0603	TDK, C1608X5R0J475K
2	1	C7	CAP, X5R 0.1uF 10V 10% 0402	MURATA, GRM155R61A104KA01
3	1	C8	CAP, X7R 1000pF 50V 10% 0402	AVX, 04025C102KAT
4	1	R1	RES, 402 OHMS 1% 1/16W 0402	VISHAY, CRCW0402402RFKED
5	1	R2	RES, 1.0M OHMS 5% 1/16W 0402	VISHAY, CRCW04021M00JNED
6	1	R3	RES, 0 OHMS 1/16W 0402	VISHAY, CRCW04020000Z0ED
7	3	R4,R5,R6	RES, 5.1K OHMS 5% 1/16W 0402	VISHAY, CRCW04025K10JNED
8	0	D1-D3, D16-D18 (OPT)	LED, SMT WHITE	NICHIA, NSSW100CT
9	0	D20-D23 (OPT)	LED, SMT RGB	NICHIA, NSCM315CT
10	0	U2	IC, SERIAL EEPROM	MICROCHIP, 24LC025-I/ST
HARDWARE FOR DEMO BOARD ONLY:				
1	1	J1	HEADER, 2X7 2MM STRAIGHT	MOLEX/WALDOM, 87831-1420
2	0	J2 (OPT)	HEADER, 2X6 2MM R/A	
3	0	J3 (OPT)	SOCKET, 2X6 2MM R/A	
4	4	E3-E6	TURRET, TESTPOINT	MILL-MAX, 2308-02
5	2	E1,E2	TURRET, TESTPOINT	MILL-MAX, 2501-02
6	4		STANDOFFS	KEYSTONE, 8831
7	1		CABLE ASSY., 8" STRIP	LINEAR RIBBON CABLE, CA-2440