



Chipsmall Limited consists of a professional team with an average of over 10 year of expertise in the distribution of electronic components. Based in Hongkong, we have already established firm and mutual-benefit business relationships with customers from,Europe,America and south Asia,supplying obsolete and hard-to-find components to meet their specific needs.

With the principle of "Quality Parts,Customers Priority,Honest Operation,and Considerate Service",our business mainly focus on the distribution of electronic components. Line cards we deal with include Microchip,ALPS,ROHM,Xilinx,Pulse,ON,Everlight and Freescale. Main products comprise IC,Modules,Potentiometer,IC Socket,Relay,Connector.Our parts cover such applications as commercial,industrial, and automotives areas.

We are looking forward to setting up business relationship with you and hope to provide you with the best service and solution. Let us make a better world for our industry!



Contact us

Tel: +86-755-8981 8866 Fax: +86-755-8427 6832

Email & Skype: info@chipsmall.com Web: www.chipsmall.com

Address: A1208, Overseas Decoration Building, #122 Zhenhua RD., Futian, Shenzhen, China



LTC4098EPDC: USB Compatible Switching Power Manager/Li-Ion Charger with Overvoltage Protection

DESCRIPTION

Demonstration Circuit 1284A is a high efficiency USB Power Manager, Li-Ion battery charger and HV buck regulator battery tracking controller, using the LTC[®]4098EPDC, and HV, high efficiency buck regulator, the LT3480EDD.

The LTC4098EPDC is available in the ultra-thin (0.55mm) 20-lead 3mmx4mm QFN surface mount package.

Design files for this circuit board are available. Call the LTC factory.

LT, LTC, LTM, LT, Burst Mode, OPTI-LOOP, Over-The-Top and PolyPhase are registered trademarks of Linear Technology Corporation. Adaptive Power, C-Load, DirectSense, Easy Drive, FilterCAD, Hot Swap, LinearView, µModule, Micropower SwitcherCAD, Multimode Dimming, No Latency ΔΣ, No Latency Delta-Sigma, No R_{SENSE}, Operational Filter, PanelProtect, PowerPath, PowerSOT, SmartStart, SoftSpan, Stage Shedding, SwitcherCAD, ThinSOT, UltraFast and VLDO are trademarks of Linear Technology Corporation. Other product names may be trademarks of the companies that manufacture the products.

PERFORMANCE SUMMARY Specifications are at T_A = 25°C

SYMBOL	PARAMETER	CONDITIONS	MIN	TYP	MAX	UNITS
V _{USB}	Bus input voltage range	Input disabled for V _{USB} ≥ 6V	4.35		30	V
HVIN	High voltage input voltage range		8		38	V
Adaptor	5V adaptor input voltage range		4.5		5.5	V
V _{OUT}	Output voltage range	Range is mode and load dependant	3.5		4.7	V
BAT	Battery float voltage	Constant voltage mode		4.2		V
I _{BAT}	Output charge current	Constant current mode		0.5	1.5	A

OPERATING PRINCIPLES

The LTC4098 is a Li-Ion battery charger/power manager that can control a preregulator for the charger input voltage. This allows for minimal power dissipation in the charger.

The LTC4098 also contains an integrated buck regulator that can provide the preregulation function, called Bat-Track™ from a 5V input supply, usually a USB port.

If the input supply is a USB port, then the load presented to the USB port can be programmed to comply with the USB standards. This load can be set to 100mA, or 500mA, as negotiated with the USB host, and is programmed using the D[2-0] inputs and the CLPROG pin resistance.

The current that the charger supplies to the battery, for non-USB applications, is also programmable via the PROG pin resistance, up to 1A.

The current available at V_{OUT} is preferentially supplied to any system load connected to V_{OUT}, the remaining current is supplied to the battery charger up to the amount set by the PROG resistor.

The current available at V_{OUT} is the USB current as negotiated with the USB host (I_{USB}) times the transformer action of the V_{OUT} switching regulator:

$$I_{USB} * \frac{V_{USB}}{V_{OUT}} * \eta(\text{buck regulator}) = I_{VOUT}$$

QUICK START GUIDE FOR DEMONSTRATION CIRCUIT 1284A

USB Compatible Switching Power Manager/Li-Ion Charger with Overvoltage Protection

LTC4098EPDC

If the battery voltage is 3.6V, and VBUS is 5V, and the negotiated USB current is 500mA, then the current available at VOUT is approximately 590mA. This will be supplied to any VOUT loads before the battery charger.

The LTC4098 also has an ideal diode function allows the maximum energy to be extracted from the battery, by minimizing the voltage drop from BAT to VOUT. The ideal diode function supports an optional external MOSFET for excellent efficiency at higher battery currents.

USB voltages higher than 6V will activate an overvoltage protect function on the LTC4098, which uses an external MOSFET to protect against application dependent input overvoltages. This is achieved by simply selecting an external MOSFET with the appropriate BV_{DSS} .

If it is desired to operate the LTC4098 from voltages higher than 6V, an external HV regulator is needed. The DC1284A board uses an LT3480, high frequency, HV, buck regulator. The interface between the LTC4098 and

the LT3480 is via the Vc pin, allowing the LT3480 to Bat-Track, and hence minimize the dissipation in the battery charger. The output of the LT3480 is used preferentially over the USB input by turning off the internal buck regulator and turning on a MOSFET to connect the output of the LT3480 to the LTC4098 VOUT pin. The presence of the LT3480 output is sensed via the "WALL" pin on the LTC4098, and the MOSFET gate is driven by the \overline{ACPR} pin. By connecting the output of the LT3480 to the VOUT pin, the LT3480 can supply both full battery charge current and full load current, without concern about meeting the USB maximum power restrictions.

The WALL pin detects the presence of an appropriate voltage to operate the LTC4980, and this could be supplied by an external adaptor, so that no additional regulator is required by the LTC4098. However, this solution will not allow the Bat-Track function to be implemented, and consequently the dissipation of the battery charger will increase.

QUICK START GUIDE FOR DEMONSTRATION CIRCUIT 1284A

USB Compatible Switching Power Manager/Li-Ion Charger with Overvoltage Protection

LTC4098EPDC

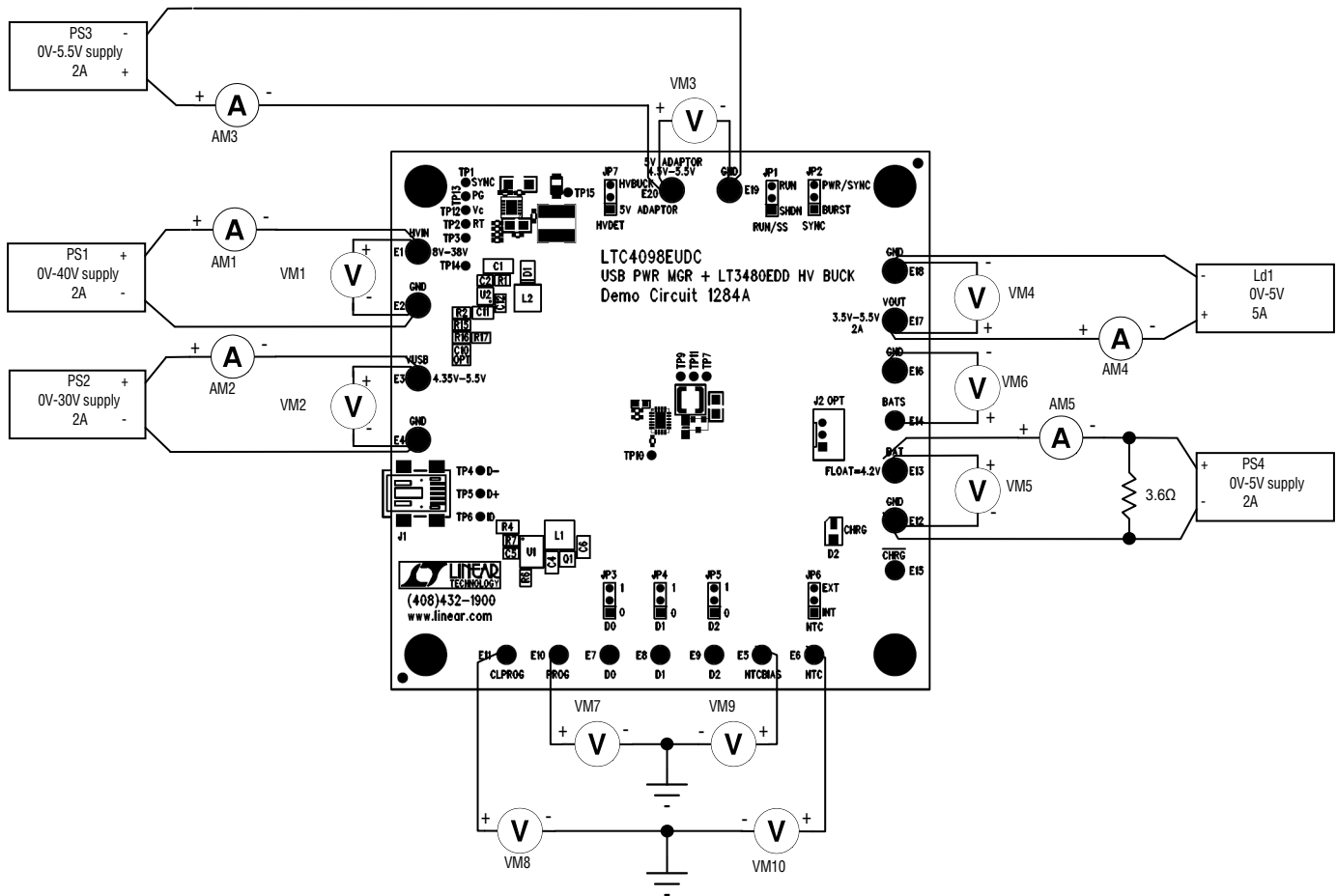

Note: All connections from equipment should be Kelvin connected directly to the Board PINS which they are connected to on this diagram and any input, or output, leads should be twisted pair

Figure1: Test Equipment Hookup Diagram

Using short twisted pair leads for any power connections, with all loads and power supplies off, refer to Figure 1 for the proper measurement and equipment setup. Follow the procedure below:

1. Select input from V_{BUS} : Set “WALL” jumper (JP7) to “5V ADAPTOR”, and “RUN/SS” jumper (JP1) to “SHDN”. Ensure that PS3 is off.
2. Set PS4, on BAT, to 3.8 V (Note PS4 has a 3.6 Ohm, 5 Watt resistor across its terminals). Turn on PS4. Verify that V_{OUT} is greater than 3.78V. Verify that $V_{BATSENS}$ equals V_{BAT} .
3. Set Ld1, on VOUT, to 100 mA. Turn on Ld1. Measure and record $V_{(VOUT,BAT)}$.
4. Set Ld1 to 1 A. Measure and record $V_{(VOUT,BAT)}$.
5. Set Ld1 to 100 mA.

QUICK START GUIDE FOR DEMONSTRATION CIRCUIT 1284A
USB Compatible Switching Power Manager/Li-Ion Charger
with Overvoltage Protection

LTC4098EPDC

6. Set NTC jumper (JP6) to INT.
7. Measure the resistance from J2.3 to JP6.3. Verify that the resistance is less than 0.25 Ω.
8. Set D2, D1, and D0 jumpers to 0, 0, and 0, respectively, to select the LTC4098 into 1X Charger ON mode. See Table 1.

Table 1: Controlled Input Current Limit

D2	D1	D0	CHARGER	I _{LIM}
0	0	0	ON	100mA(1x)
0	0	1	ON	1A(10x)
0	1	0	ON	500mA(5x)
0	1	1	OFF	500μA(SUSP)
1	0	0	OFF	100mA(1x)
1	0	1	OFF	1A(10x)
1	1	0	OFF	500mA(5X)
1	1	1	OFF	2.5mA(SUSP)

9. SET PS2, on VBUS, to 5 V. Turn on PS2. Verify that the input current is greater than 90 mA and less than 100 mA and V_{CLPROG} is approximately 1.188 V.
10. Verify that the CHRG LED is solid green. Measure V_{NTC} and V_{NTCBIAS}.
11. Remove the NTC jumper, JP6. Observe the CHRG LED slow blinking rate. Measure V_{NTC} and V_{NTCBIAS}.
12. Replace the NTC jumper (JP6) to “INT”.
13. Using an oscilloscope view the voltage waveform on VOUT and BAT. Verify that the ripple voltage is less than 50 mV on both nodes.
14. Reduce PS4 to 2.65 V. Reduce Ld1 to 50 mA. Verify that V_{PROG} is approximately 0.1 Volts.
15. Increase the voltage on PS4 to 3.8 V. Increase Ld1 to 100 mA.

16. Set D2, D1, and D0 to 0, 1, and 0, respectively to select the LTC4098 into 5X, Charger ON mode. See Table 1.
17. Verify that the input current is greater than 400 mA and less than 500 mA and V_{CLPROG} is approximately 1.188 V.
18. Set D2, D1, and D0 to 1, 1, and 0, respectively to select the LTC4098 into 5X mode, charger OFF.
19. Verify that the input current is less than 100 mA and V_{CLPROG} is less than 0.3 V. Set D2, D1, and D0 to 0, 0, and 1, respectively to select the LTC4098 into 10X, Charger ON mode. Verify that I_{BAT}(charge) = 500 mA.
20. Increase Ld1 to 1.2 Amps and verify that the input current is greater than 850 mA and less than 1A.
21. Reduce Ld1 to 500 mA. Measure the following currents and voltages and calculate the efficiency.

$$I_{BAT} = \frac{V_{PROG} \cdot 1000}{2000}$$

$$Eff = \frac{V_{OUT} \cdot I_{VOUT} + V_{BAT} \cdot I_{BAT}}{V_{VBUS} \cdot I_{VBUS}}$$

22. Reduce Ld1 to 100 mA.
23. Remove PS4. Using an oscilloscope view the voltage waveform on V_{OUT} and BAT. Verify that the ripple voltage is less than 50 mV on both nodes. Increase PS2 to 30 V and verify that Q1 has shut off by verifying, and recording, that V_{OVSENS} = 6~6.5V, V_{OVGATE} = 0 V, V_{C4} = 0 V.
24. Turn off PS2.
25. Set PS4 to 3.6V and reconnect. Set Ld1 to 1 A. Verify that V_{OUT} ≈ V_{BAT} – 30mV.
26. Select input from 5V Adaptor, but setting “Wall” (JP7) jumper to “5V Adaptor”. Set PS3 to 4.4 V. Turn on PS3.
27. Verify that V_{OUT} = 4.4 V.

QUICK START GUIDE FOR DEMONSTRATION CIRCUIT 1284A

USB Compatible Switching Power Manager/Li-Ion Charger with Overvoltage Protection

LTC4098EPDC

28. Turn off PS3. Set WALL jumper (JP7) to “HV BUCK”.
 29. Set PS1 to 8 V. Set “RUN/SS” jumper (JP1) to “RUN”.
 30. Set PS4 to 3.3 V.
 31. Turn on PS1.
 32. Verify that $V_{OUT} = 3.6\sim 3.7$ V.
 33. Set PS4 to 4.1 V, verify that V_{OUT} is 4.4~4.5V.
 34. Turn off PS1.
 35. Set PS1 to 38 V, and repeat tests 32-35.
 36. Turn off all supplies.
-

APPLICATION INFORMATION

This demo circuit is designed to demonstrate the full capability of the device. Not all components are required in all applications. The critical circuit components are on the top of the board near the IC.

The VBUS input capacitor network of C3 and R3 is used to dampen input source inductances that commonly occur in laboratory setups with twisted leads

and a bench power supply. When using a USB cable or adaptor cable this input damping network will likely not be required. Please note that the in-circuit capacitance of C4 is approximately 8 μ F at 5V. However, this capacitance is disconnected from the USB input by Q1. Therefore the USB load capacitance is not exceeded, as Q1 will limit the maximum inrush current.

Figure 2: Schematic

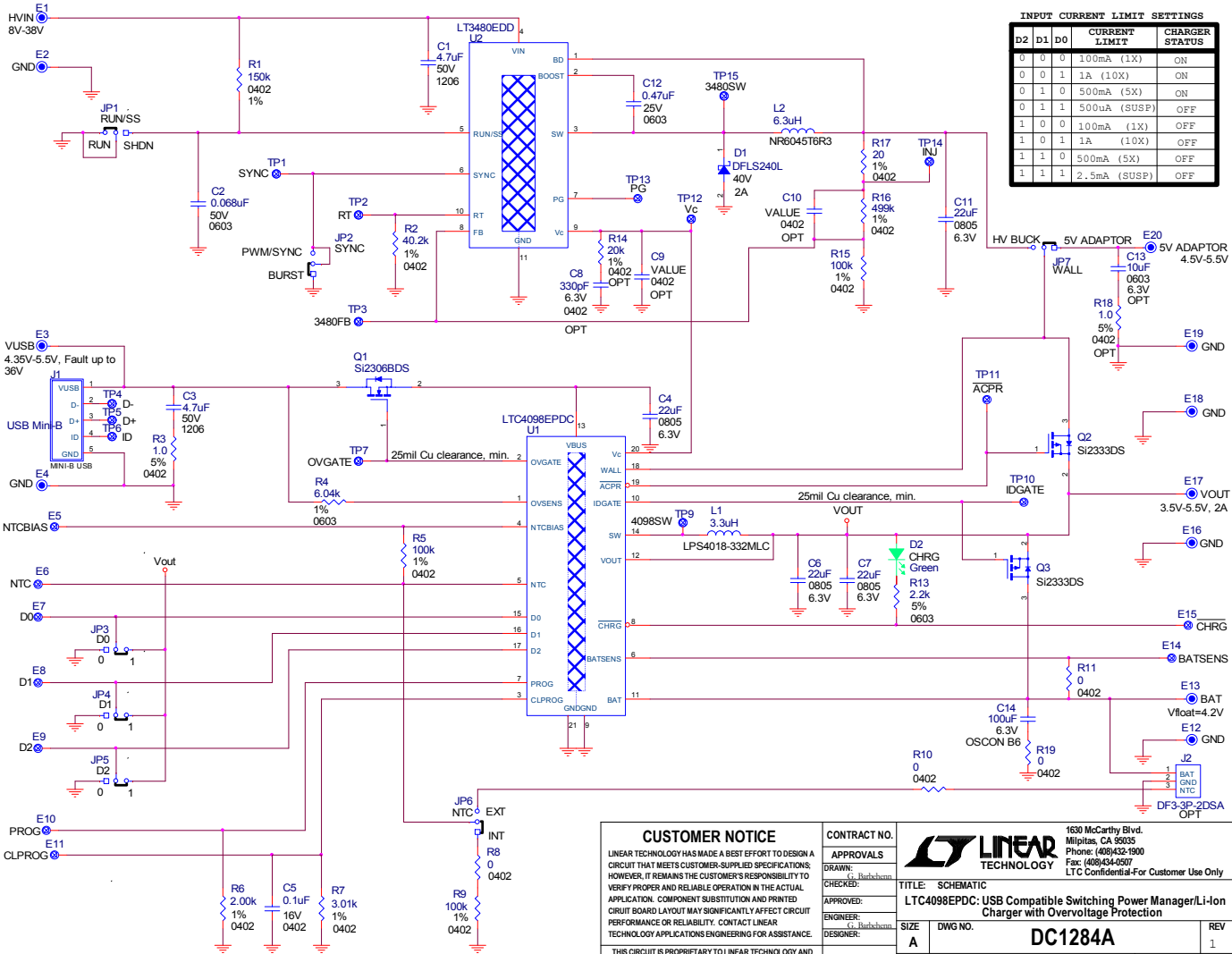

INPUT CURRENT LIMIT SETTINGS

D2	D1	D0	CURRENT LIMIT	CHARGER STATUS
0	0	0	100mA (1X)	ON
0	0	1	1A (10X)	ON
0	1	0	500mA (5X)	ON
0	1	1	500uA (SUSP)	OFF
1	0	0	100mA (1X)	OFF
1	0	1	1A (10X)	OFF
1	1	0	500mA (5X)	OFF
1	1	1	2.5mA (SUSP)	OFF

<p>CUSTOMER NOTICE</p> <p>LINEAR TECHNOLOGY HAS MADE A BEST EFFORT TO DESIGN A CIRCUIT THAT MEETS CUSTOMER-SUPPLIED SPECIFICATIONS. HOWEVER, IT REMAINS THE CUSTOMER'S RESPONSIBILITY TO VERIFY PROPER AND RELIABLE OPERATION IN THE ACTUAL APPLICATION. COMPONENT SUBSTITUTION AND PRINTED CIRCUIT BOARD LAYOUT MAY SIGNIFICANTLY AFFECT CIRCUIT PERFORMANCE OR RELIABILITY. CONTACT LINEAR TECHNOLOGY APPLICATIONS ENGINEERING FOR ASSISTANCE.</p> <p>THIS CIRCUIT IS PROPRIETARY TO LINEAR TECHNOLOGY AND SUPPLIED FOR USE WITH LINEAR TECHNOLOGY PARTS.</p>	<p>CONTRACT NO.</p>	<p>1630 McCarthy Blvd. Milpitas, CA 95035 Phone: (408)432-1900 Fax: (408)434-0507 LTC Confidential-For Customer Use Only</p>	
	<p>APPROVALS</p>		<p>TITLE: SCHEMATIC</p>
	<p>DRAWN: G. Burkham</p>		<p>LTC4098EPDC: USB Compatible Switching Power Manager/Li-Ion Charger with Overvoltage Protection</p>
	<p>CHECKED: G. Burkham</p>		<p>SIZE: A DWG NO. DC1284A REV 1</p>
	<p>DESIGNER: G. Burkham</p>		<p>DATE: Tuesday, November 27, 2007 SHEET 1 OF 1</p>

LTC4098EPDC

QUICK START GUIDE FOR DEMONSTRATION CIRCUIT 1284A
 USB Compatible Switching Power Manager/Li-Ion Charger
 with Overvoltage Protection

QUICK START GUIDE FOR DEMONSTRATION CIRCUIT 1284A
USB Compatible Switching Power Manager/Li-Ion Charger
with Overvoltage Protection

LTC4098EPDC

	Qty	Reference	Part Description	Manufacture / Part #
REQUIRED CIRCUIT COMPONENTS:				
1	1	C1	CAP, CHIP, X5R, 4.7 μ F, \pm 10%, 50V, 1206	MURATA, GRM31CR71H475KA12L
2	1	C2	CAP, CHIP, X5R, 0.068 μ F, \pm 10%, 50V, 0603	MURATA, GRM188R71H683K
3	3	C4,C7,C9	CAP, CHIP, X5R, 22 μ F, \pm 20%, 6.3V, 0805	TAIYO-YUDEN, JMK212BJ226MG
4	1	C5	CAP, CHIP, X7R, 0.1 μ F, \pm 10%, 16V, 0402	MURATA, GRM155R71C104KA88
5	1	C11	CAP, CHIP, X7R, 0.47 μ F, \pm 10%, 25V, 0603	MURATA, GRM188R71E474K
6	1	D1	DIODE, SCHOTTKY, 2A, 40V, PowerDI123	DIODES INC., DFLS240L
7	1	L1	IND, SMT, 3.3 μ H, 80m Ω , \pm 20%, 2.2A, 4mmX4mm	COILCRAFT, LPS4018-332MLC
8	1	L2	IND, SMT, 6.3 μ H, 38m Ω , \pm 30%, 3.8A, 6.0mmX6.0mm	TAIYO YUDEN, NR6045T6R3M
9	1	Q1	MOSFET, 30V, 65m Ω , 3.5A, SOT-23	VISHAY, Si2306BDS
10	1	Q2	MOSFET, -12V, 35m Ω , -5.3A, SOT-23	VISHAY, Si2333DS
11	1	R1	RES, CHIP, 150k Ω , \pm 1%, 1/16W, 0402	VISHAY, CRCW0402150KFKED
12	1	R2	RES, CHIP, 40.2k Ω , \pm 1%, 1/16W, 0402	VISHAY, CRCW040240K2FKED
13	1	R4	RES, CHIP, 6.04k Ω , \pm 1%, 1/10W, 0603	VISHAY, CRCW06036K04FKED
14	1	R6	RES, CHIP, 2.00k Ω , \pm 1%, 1/16W, 0402	VISHAY, CRCW04022K00FKED
15	1	R7	RES, CHIP, 3.01k Ω , \pm 1%, 1/16W, 0402	VISHAY, CRCW04023K01FKED
16	1	R14	RES, CHIP, 0 Ω jumper, 1/16W, 0402	VISHAY, CRCW04020000Z0ED
17	1	R17	RES, CHIP, 100k Ω , \pm 1%, 1/16W, 0402	VISHAY, CRCW0402100KFKED
18	1	R18	RES, CHIP, 499k Ω , \pm 1%, 1/16W, 0402	VISHAY, CRCW0402499KFKED
19	1	U1	USB Compatible Switching Power Manager/Li-Ion Charger with Overvoltage Protection	LINEAR TECH., LTC4098EPDC
20	1	U2	38V, 2A, 2.4MHz Step-Down Switching Regulator with 70 μ A Quiescent Current	LINEAR TECH., LT3480EDD
ADDITIONAL DEMO BOARD CIRCUIT COMPONENTS:				
1	1	C3	CAP, CHIP, X5R, 4.7 μ F, \pm 10%, 50V, 1206	MURATA, GRM31CR71H475KA12L
2	1	C6	CAP, CHIP, X5R, 100 μ F, \pm 20%, 6.3V, 1206	MURATA, GRM31CR60J107ME39L
3	0	C8-OPT	CAP, CHIP, 0402	User determined
4	1	C10	CAP, CHIP, X5R, 10 μ F, \pm 20%, 6.3V, 0603	TDK,C1608X5R0J106M
5	1	D2	DIODE, LED, GREEN, 1206	PANASONIC, LN1351-C-TR
6	1	Q3	MOSFET, -12V, 35m Ω , -5.3A, SOT-23	VISHAY, Si2333DS
7	5	R3,R11,R12,R13,R20	RES, CHIP, 1.0 Ω , \pm 5%, 1/16W, 0402	VISHAY, CRCW04021R00JNED
8	2	R5, R8	RES, CHIP, 100k Ω , \pm 1%, 1/16W, 0402	VISHAY, CRCW0402100KFKED
9	2	R9,R10	RES, CHIP, 0 Ω jumper, 1/16W, 0402	VISHAY, CRCW04020000Z0ED
10	1	R15	RES, CHIP, 1k Ω , \pm 5%, 1/10W, 0603	VISHAY, CRCW06031K00JNED
11	1	R16	RES, CHIP, 10k Ω , \pm 5%, 1/16W, 0402	VISHAY, CRCW040210K0JNED
12	1	R19	RES, CHIP, 20 Ω , \pm 5%, 1/16W, 0402	VISHAY, CRCW040220R0JNED
HARDWARE FOR DEMO BOARD ONLY:				
1	11	E1,E2,E4,E5,E10,E11,E14,E15,E16,E18,E19	Turret, 0.09"	MILL-MAX, 2501-2
2	8	E3,E6,E7,E8,E9,E12,E13,E17	Turret, 0.061"	MILL-MAX, 2308-2
3	1	J1	CONN, USB MINI-B	TYCO,1734035-2
4	0	J2-OPT	CONN, Battery	HIROSE, DF3-3P-2DSA
5	7	JP1,JP2,JP3,JP4,JP5,JP6,JP7	3 Pin Jumper, 2mm	SAMTEC, TMM-103-02-L-S
6	7	JP1,JP2,JP3,JP4,JP5,JP6,JP7	SHUNT 2mm	SAMTEC, 2SN-BK-G
7	4		STAND-OFF, NYLON 0.375" tall (SNAP ON)	KEYSTONE, 8832 (SNAP ON)

Figure 3: DC1284 BOM