



Chipsmall Limited consists of a professional team with an average of over 10 year of expertise in the distribution of electronic components. Based in Hongkong, we have already established firm and mutual-benefit business relationships with customers from,Europe,America and south Asia,supplying obsolete and hard-to-find components to meet their specific needs.

With the principle of “Quality Parts,Customers Priority,Honest Operation,and Considerate Service”,our business mainly focus on the distribution of electronic components. Line cards we deal with include Microchip,ALPS,ROHM,Xilinx,Pulse,ON,Everlight and Freescale. Main products comprise IC,Modules,Potentiometer,IC Socket,Relay,Connector.Our parts cover such applications as commercial,industrial, and automotives areas.

We are looking forward to setting up business relationship with you and hope to provide you with the best service and solution. Let us make a better world for our industry!



Contact us

Tel: +86-755-8981 8866 Fax: +86-755-8427 6832

Email & Skype: info@chipsmall.com Web: www.chipsmall.com

Address: A1208, Overseas Decoration Building, #122 Zhenhua RD., Futian, Shenzhen, China



DESCRIPTION

Demonstration Circuit 1314A is a Mean-Squared Power Detector featuring the LT[®]5581 IC.

The LT5581 is a wide dynamic range Mean Squared RF Power Detector, operational from 10MHz to 6GHz. The input dynamic range at 6GHz, with ± 1 dB nonlinearity, is 40dB (from -34 dBm to $+6$ dBm, single-ended 50Ω input). The detector output voltage slope is normally 31mV/dB, and the typical output variation over temperature is ± 0.5 dB at 880MHz.

The 1314A Demo Circuit is optimized for wide frequency range of 10MHz to 2.2GHz. However, input match can be optimized up to 6GHz with simple external matching.

Design files for this demo board are available. Call the LTC factory.

LTC is a trademark of Linear Technology Corporation

Typical Performance Summary ($V_{CC} = 3.3V$, $ENBL = 3.3V$, $T_A = 25^\circ C$, unless otherwise noted. Test circuit shown in Figure 1.)

PARAMETER	CONDITION	VALUE
Supply Voltage		2.7V to 5.25V
Supply Current		1.4mA
Shutdown Current	ENBL = Low	0.2 μ A
ENBL Voltage	Low, Chip Disabled HIGH, Chip Enabled	0.3V max 2V min
ENBL Input Current	$V_{ENBL} = 0V$ $V_{ENBL} = 5V$	0 μ A 20 μ A
Output Start Voltage	No Input Signal Present	0.2V
Rise Time	0.2V to 1.6V, 10% to 90%, $C_1 = 22nF$, $F_{RF} = 2140$ MHz	1 μ s
Fall Time	1.6V to 0.2V, 90% to 10%, $C_1 = 22nF$, $F_{RF} = 2140$ MHz	8 μ s
Input Frequency Range	Optimized for DC1314A demo board	10MHz to 6GHz
f = 450MHz		
Linear Dynamic Range	± 1 dB linearity error	40 dB
Slope		31mV/dB
Logarithmic Intercept		-42dBm
Output Variation vs Temperature	$P_{IN} = -34$ to $+6$ dBm	± 1 dB
Deviation from CW Response	12 dB peak-to-average ratio (4 carrier WCDMA)	± 0.5 dB
f = 5800MHz		
Linear Dynamic Range	± 1 dB linearity error	31dB
Slope		31mV/dB
Logarithmic Intercept		-33dBm
Output Variation vs Temperature	$P_{IN} = -25$ to $+6$ dBm	± 1 dB
Deviation from CW Response	WiMAX OFDM Burst; $P_{IN} = -25$ to $+6$ dBm	± 0.2 dB

QUICK START PROCEDURE

Demonstration Circuit 1314A is easy to set up to evaluate the performance of the LT5581. Refer to Figure 1 for measurement equipment setup and follow the procedure below:

Connect voltmeter's negative (-) lead to demo board GND test point (E4).

Connect voltmeter's positive (+) lead to the demo board OUTPUT test point (J2).

Connect DC power supply's negative (-) output to demo board GND test point (E3 and E4).

Connect DC power supply's positive (+) output (2.7V to 5.25V) to demo board V_{CC} test point (E1 and E2).

Do not exceed 5.5V, the absolute maximum supply voltage.

Connect signal generator's output to demo board INPUT port (SMA connector J1) via coaxial cable. A 3dB attenuator may be inserted to improve input match.

Using a jumper cable, connect demo board V_{CC} test point (E1) to ENBL test point (E2). Now the detector is enabled (on) and is ready for measurement.

NOTES:

- 1. The voltage on the EN test point must never exceed $V_{CC} + 0.3V$.**
- 2. For digitally modulated signals, an oscilloscope can be used to observe the AC components of the output.**
- 3. Pins 4, 5 and 6 are internally connected to ground. In the customer designs, the users have the choice to leave them as no connect as in the demo board, or connect them to ground.**

Pin 8, C_{SQ} is the Optional Low Frequency Range Extension Capacitor. Use this pin for frequencies below 250MHz. Connect 0.01uF from Pin 8 to ground for 10MHz operation.

Apply RF input signal and measure OUTPUT DC voltages.

Do not exceed +15dBm, the absolute maximum RF input power.

DEMO BOARD MODIFICATIONS:

Modifications at RF input port for other frequency ranges:

FREQUENCY RANGE	RF _{IN} MATCH	
	L1	C1
1GHz to 2.2GHz	2.2nH	1.5pF
2GHz to 2.6GHz	1.2nH	1.5pF
2.6GHz to 3.4GHz	0	1pF
3.8GHz to 5.5GHz	0	0.5pF
4.6GHz to 6GHz	0	0

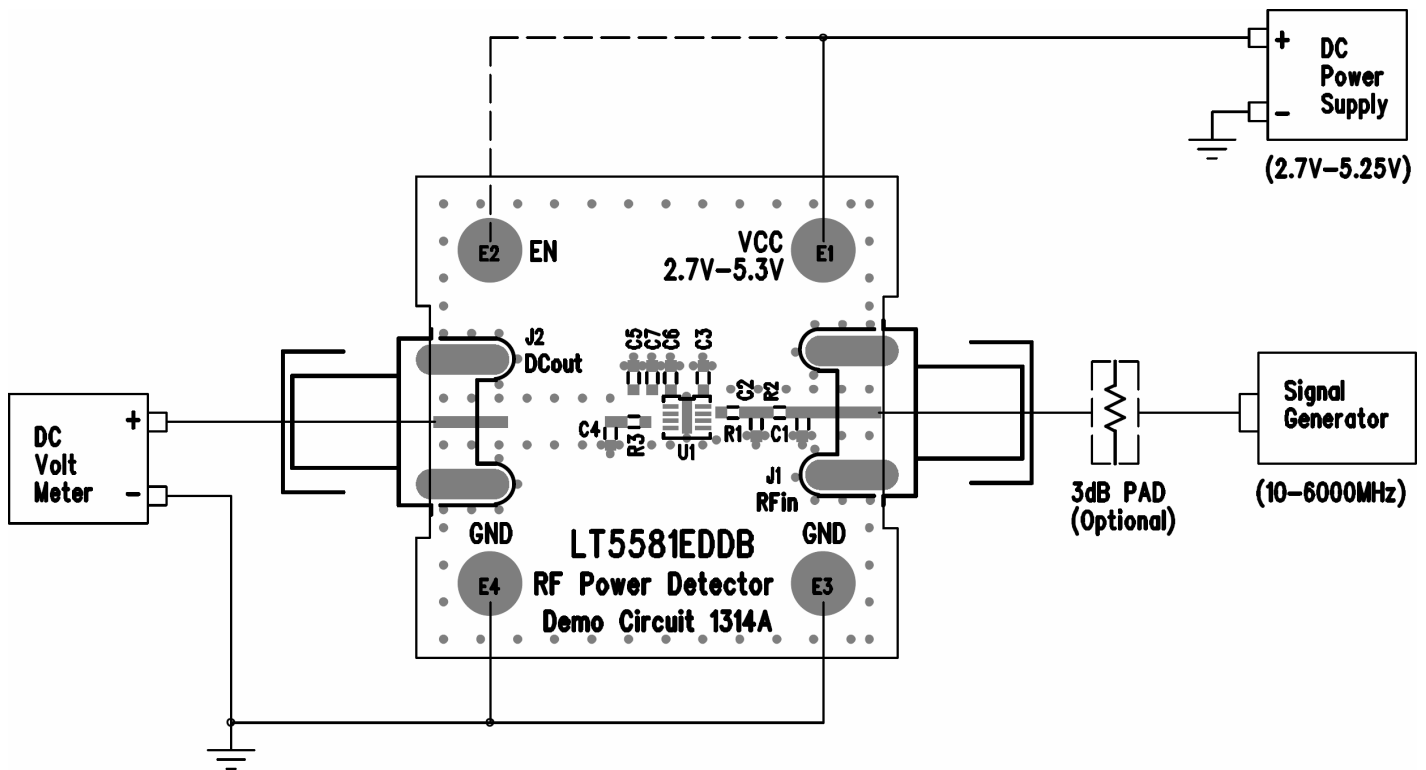
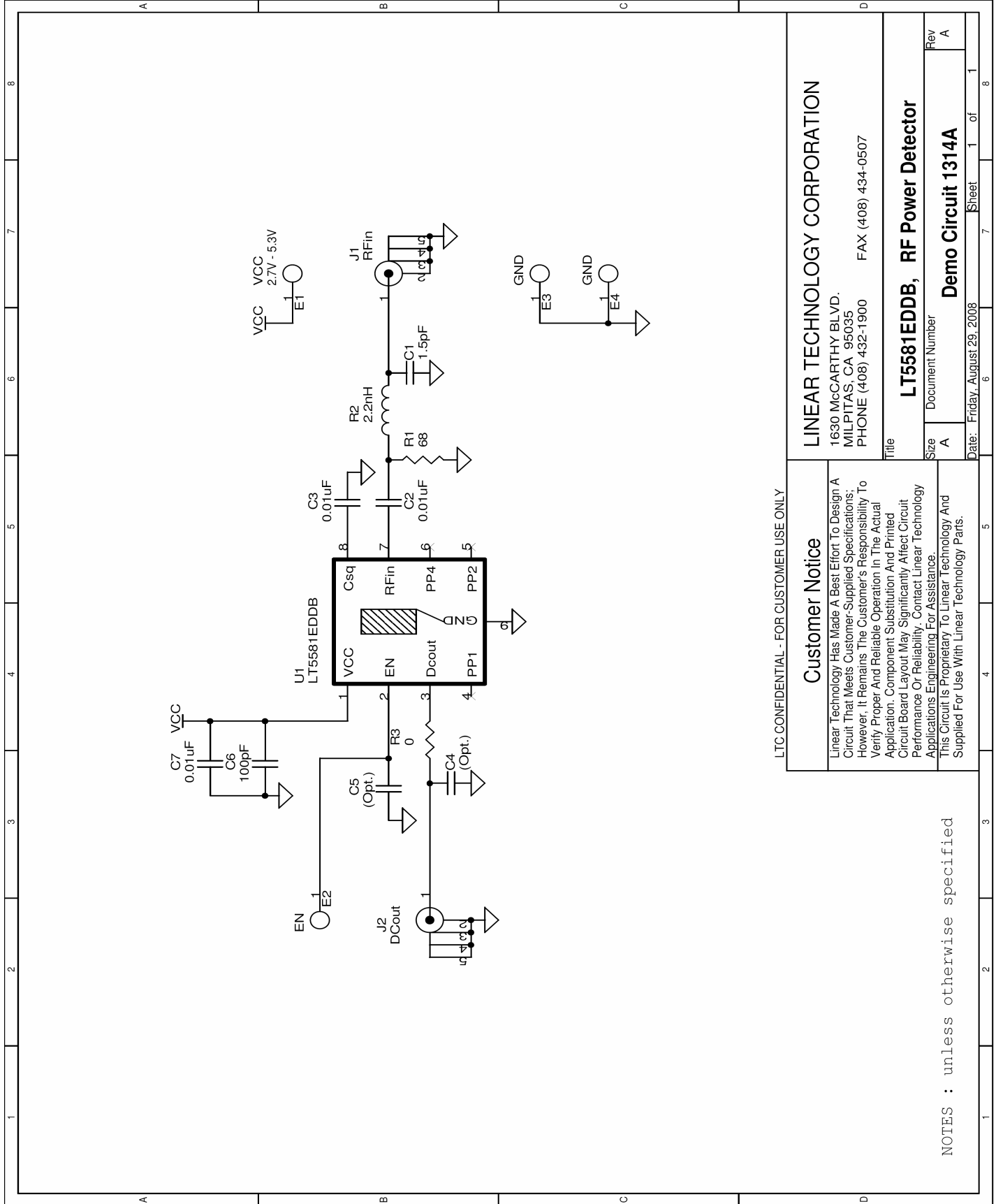

Figure 1. Proper Measurement Equipment Setup

QUICK START GUIDE FOR DEMONSTRATION CIRCUIT 1314A

RF POWER DETECTOR



LTC-CONFIDENTIAL - FOR CUSTOMER USE ONLY

Customer Notice

Linear Technology Has Made A Best Effort To Design A Circuit That Meets Customer-Supplied Specifications; However, It Remains The Customer's Responsibility To Verify Proper And Reliable Operation In The Actual Application. Component Substitution And Printed Circuit Board Layout May Significantly Affect Circuit Performance Or Reliability. Contact Linear Technology Applications Engineering For Assistance.
This Circuit Is Proprietary To Linear Technology And Supplied For Use With Linear Technology Parts.

LINEAR TECHNOLOGY CORPORATION

1630 McCARTHY BLVD.
MILPITAS, CA 95035
PHONE (408) 432-1900 FAX (408) 434-0507

LT5581EDDB, RF Power Detector

Title	
Size	Document Number
A	LT5581EDDB, RF Power Detector
Rev	Demo Circuit 1314A
Date: Friday, August 29, 2008	
Sheet	1 of 1

NOTES : unless otherwise specified