



Chipsmall Limited consists of a professional team with an average of over 10 year of expertise in the distribution of electronic components. Based in Hongkong, we have already established firm and mutual-benefit business relationships with customers from,Europe,America and south Asia,supplying obsolete and hard-to-find components to meet their specific needs.

With the principle of "Quality Parts,Customers Priority,Honest Operation,and Considerate Service",our business mainly focus on the distribution of electronic components. Line cards we deal with include Microchip,ALPS,ROHM,Xilinx,Pulse,ON,Everlight and Freescale. Main products comprise IC,Modules,Potentiometer,IC Socket,Relay,Connector.Our parts cover such applications as commercial,industrial, and automotives areas.

We are looking forward to setting up business relationship with you and hope to provide you with the best service and solution. Let us make a better world for our industry!



Contact us

Tel: +86-755-8981 8866 Fax: +86-755-8427 6832

Email & Skype: info@chipsmall.com Web: www.chipsmall.com

Address: A1208, Overseas Decoration Building, #122 Zhenhua RD., Futian, Shenzhen, China



HIGH DYNAMIC RANGE DOWNCONVERTING MIXER

DESCRIPTION

Demonstration Circuit 1431A-A is a 600MHz to 1.3GHz high dynamic range downconverting mixer featuring the LTC[®]5540. The LTC5540 is part of a family of high dynamic range, passive downconverting mixers covering the 600MHz to 4GHz frequency range. **The Demo Circuit 1431A-A and the LTC5540 are optimized for 600MHz to 1.3GHz RF applications. The LO frequency must fall within the 700MHz to 1.2GHz range for optimum performance.**

The LTC5540 is designed for 3.3V operation, however the IF amplifier can be powered by 5V for the highest P1dB. An integrated SPDT LO switch with fast switching accepts two active LO signals, while providing high isolation.

The LTC5540's high conversion gain and high dynamic range enable the use of lossy IF filters in high-selective receiver designs, while minimizing the total solution cost, board space and system-level variation.

High Dynamic Range Downconverting Mixer Family

DEMO #	IC PART #	RF RANGE	LO RANGE
DC1431A-A	LTC5540	600MHz-1.3GHz	700MHz-1.2GHz
DC1431A-B	LTC5541	1.3GHz-2.3GHz	1.4GHz-2.0GHz
DC1431A-C	LTC5542	1.6GHz-2.7GHz	1.7GHz-2.5GHz
DC1431A-D	LTC5543	2.3GHz-4.0GHz	2.4GHz-3.6GHz

Design files for this circuit board are available. Call the LTC factory.

 , LT, LTC, LTM, Linear Technology and the Linear Logo are registered trademarks of Linear Technology Corporation. All other trademarks are the property of their respective owners.

TABLE 1. TYPICAL PERFORMANCE SUMMARY

T_A = 25°C, V_{CC} = 3.3V, V_{CCIF} = 3.3V, SHDN = Low, P_{LO} = 0dBm, P_{RF} = -3dBm (Δf = 2MHz for two-tone IIP3 tests), unless otherwise noted.

PARAMETER	CONDITIONS	VALUE	UNITS
V _{CC} Supply Voltage Range		3.1 to 3.5	V
V _{CCIF} Supply Voltage Range		3.1 to 5.3	V
Total Supply Current (V _{CC} + V _{CCIF})		193	mA
Total Supply Current During Shutdown	SHDN = High	≤ 500	μA
SHDN Input Low Voltage (IC On)		< 0.3	V
SHDN Input High Voltage (IC Off)		> 3	V
LOSEL Input Low Voltage (LO1 Selected)		< 0.3	V
LOSEL Input High Voltage (LO2 Selected)		> 3	V
LO Input Frequency Range		700 to 1200	MHz
LO Input Return Loss	Z ₀ = 50Ω, f _{LO} = 700MHz to 1200MHz	> 12	dB
LO Input Power Range	f _{LO} = 700MHz to 1200MHz	-4 to 6	dBm
RF Input Frequency Range	Low-Side LO High-Side LO	800 to 1300 600 to 1100	MHz
RF Input Return Loss	Z ₀ = 50Ω, f _{RF} = 600MHz to 1300MHz	> 12	dB

LTC5540

TYPICAL PERFORMANCE SUMMARY, CONTINUED

$T_A = 25^\circ\text{C}$, $V_{CC} = 3.3\text{V}$, $V_{CCIF} = 3.3\text{V}$, SHDN = Low, $P_{LO} = 0\text{dBm}$, $P_{RF} = -3\text{dBm}$ ($\Delta f = 2\text{MHz}$ for two-tone IIP3 tests), unless otherwise noted.

IF Output Frequency (Can be re-matched for other frequencies.)		190	MHz
IF Output Return Loss		> 12	dB
LO to RF Leakage	$f_{LO} = 700\text{MHz}$ to 1200MHz	< -30	dBm
LO to IF Leakage	$f_{LO} = 700\text{MHz}$ to 1200MHz	< -37	dBm
LO Switch Isolation	LO1 Selected, $700\text{MHz} < f_{LO} < 1200\text{MHz}$ LO2 Selected, $700\text{MHz} < f_{LO} < 1200\text{MHz}$	> 50 > 47	dB
RF to LO Isolation	$f_{RF} = 600\text{MHz}$ to 1300MHz	> 55	dB
RF to IF Isolation	$f_{RF} = 600\text{MHz}$ to 1300MHz	> 37	dB

Low-Side LO Downmixer Application: RF = 800MHz to 1300MHz, IF = 190MHz, $f_{LO} = f_{RF} - f_{IF}$

PARAMETER	CONDITIONS	VALUE	UNITS
Conversion Gain	RF = 900MHz	7.0	dB
	RF = 1100MHz	7.8	
	RF = 1300MHz	8.0	
Input 3 rd Order Intercept	RF = 900MHz	24.4	dBm
	RF = 1100MHz	24.1	
	RF = 1300MHz	23.6	
SSB Noise Figure	RF = 900MHz	10.6	dB
	RF = 1100MHz	10.5	
	RF = 1300MHz	10.3	
SSB Noise Figure Under Blocking	$f_{RF} = 900\text{MHz}$, $f_{LO} = 710\text{MHz}$ $f_{BLOCK} = 1000\text{MHz}$, $P_{BLOCK} = 5\text{dBm}$	16.7	dB
2RF – 2LO Output Spurious Product ($f_{RF} = f_{LO} + f_{IF}/2$)	$f_{RF} = 805\text{MHz}$ at -10dBm , $f_{LO} = 710\text{MHz}$	-61.5	dBc
3RF – 3LO Output Spurious Product ($f_{RF} = f_{LO} + f_{IF}/3$)	$f_{RF} = 773.33\text{MHz}$ at -10dBm , $f_{LO} = 710\text{MHz}$	-68	dBc
Input 1dB Compression	RF = 900MHz, $V_{CCIF} = 3.3\text{V}$	11	dBm
	RF = 900MHz, $V_{CCIF} = 5\text{V}$	14	

High-Side LO Downmixer Application: RF = 600MHz to 1100MHz, IF = 190MHz, $f_{LO} = f_{RF} + f_{IF}$

PARAMETER	CONDITIONS	VALUE	UNITS
Conversion Gain	RF = 700MHz	7.6	dB
	RF = 900MHz	7.9	
	RF = 1100MHz	7.9	
Input 3 rd Order Intercept	RF = 700MHz	26.5	dBm
	RF = 900MHz	25.9	
	RF = 1100MHz	23.8	
SSB Noise Figure	RF = 700MHz	10.0	dB
	RF = 900MHz	9.9	
	RF = 1100MHz	10.4	
SSB Noise Figure Under Blocking	$f_{RF} = 900\text{MHz}$, $f_{LO} = 1090\text{MHz}$ $f_{BLOCK} = 800\text{MHz}$, $P_{BLOCK} = 5\text{dBm}$	16.2	dB
2LO – 2RF Output Spurious Product ($f_{RF} = f_{LO} - f_{IF}/2$)	$f_{RF} = 995\text{MHz}$ at -10dBm , $f_{LO} = 1090\text{MHz}$	-70	dBc
3LO – 3RF Output Spurious Product ($f_{RF} = f_{LO} - f_{IF}/3$)	$f_{RF} = 1026.67\text{MHz}$ at -10dBm , $f_{LO} = 1090\text{MHz}$	-75	dBc
Input 1dB Compression	RF = 900MHz, $V_{CCIF} = 3.3\text{V}$	11	dBm
	RF = 900MHz, $V_{CCIF} = 5\text{V}$	14.5	

APPLICATIONS NOTE

For detailed applications information, please refer to the LTC5540 datasheet.

ABSOLUTE MAXIMUM RATINGS

NOTE. Stresses beyond Absolute Maximum Ratings may cause permanent damage to the device. Exposure to any Absolute Maximum Rating condition for extended periods may affect device reliability and lifetime.

Mixer Supply Voltage (V_{CC1} , V_{CC2}).....	3.8V
LO Switch Supply Voltage (V_{CC3}).....	3.8V
IF Supply Voltage (IF+, IF-).....	5.5V
Shutdown Voltage (SHDN).....	-0.3V to $V_{CC} + 0.3V$
LO Select Voltage (LOSEL).....	-0.3V to $V_{CC} + 0.3V$
LO1, LO2 Input Power (0.2GHz to 2GHz).....	9dBm
LO1, LO2 Input DC Voltage.....	$\pm 0.5V$
RF Input Power (0.2GHz to 2GHz).....	15dBm
RF Input DC Voltage.....	$\pm 0.1V$
Operating Temperature Range.....	-40°C to 85°C

SUPPLY VOLTAGE RAMPING

Fast ramping of the supply voltage can cause a current glitch in the internal ESD protection circuits. Depending on the supply inductance, this could result in a supply voltage transient that exceeds the maximum rating. A supply voltage ramp time of greater than 1ms is recommended.

Do not clip powered test leads directly onto the demonstration circuit's VCC and VCC_IF terminals. Instead, make all necessary connections with power supplies turned off, then increase to operating voltage.

SHUTDOWN FEATURE

When the SHDN voltage is logic Low (<0.3V), the chip is enabled. When the SHDN voltage is logic High (>3V), the chip is disabled, and the current consumption is reduced to below 500 μ A. The SHDN must be pulled Low or High. If left floating, the On/Off state of the IC will be indeterminate. A logic table for the SHDN is shown in Table 2.

TABLE 2. SHDN LOGIC TABLE

SHDN	IC STATE
Low	On
High	Off

LO SWITCH

The LTC5540 features an integrated SPDT switch designed for high isolation and fast (<50ns) switching. The LO switch is controlled by the LOSEL logic control. The LOSEL must be pulled Low or High. If left floating, the LO selection will be indeterminate. A logic table for the LO switch is shown in Table 3.

TABLE 3. LO SWITCH LOGIC TABLE

LOSEL	ACTIVE LO INPUT
Low	LO1
High	LO2

RF INPUT

The RF input of Demonstration Circuit 1431A-A is matched to 50 Ω from 600MHz to 1.3GHz with better than 12dB return loss. **For the RF input to be matched, the selected LO input must be driven.** The RF input impedance is somewhat dependent on LO frequency and, to a lesser extent, LO input power.

LO INPUTS

The LTC5540's LO amplifiers are optimized for the 700MHz to 1.2GHz LO frequency range. LO frequencies above and below this frequency range may be used with degraded performance.

The LO1 and LO2 inputs are always 50 Ω -matched when V_{CC} is applied to the chip, even when the chip is shutdown. The DC resistance of the selected LO input is approximately 23 Ω , and the unselected input is approximately 50 Ω .

The nominal LO input level is 0dBm. The LO input power range is between -4dBm and 6dBm. LO input power greater than 6dBm may cause conduction of the internal ESD diodes and should be avoided.

IF OUTPUT

Demonstration Circuit 1431A-A features a single-ended, 50Ω-matched IF output for 190MHz. The impedance matching is realized with a bandpass topology using an IF transformer as shown in Figure 1.

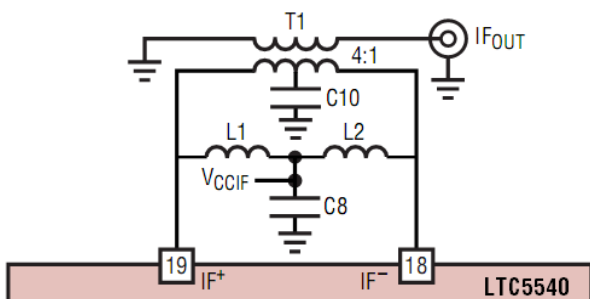

Figure 1. IF Output with Bandpass Matching

Demonstration Circuit 1431A-A can be easily re-configured for other IF frequencies by simply replacing inductors L1 and L2. L1 and L2 values for several common IF frequencies are presented in Table 4, and return losses are plotted in Figure 2.

TABLE 4. L1, L2 vs. IF FREQUENCIES

IF FREQUENCY (MHz)	L1, L2 (nH)
140	270
190	150
240	100
380	33
450	22

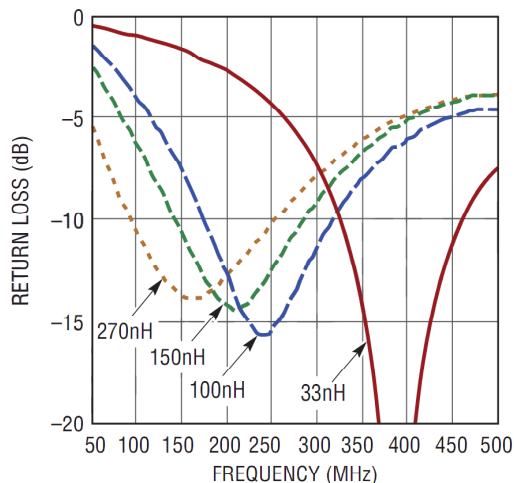

Figure 2. IF Output Return Loss

For IF frequencies below 70MHz, the values of L1 and L2 become unreasonably high, and the lowpass topology shown in Figure 3 is preferred. See the LTC5540 datasheet for details.

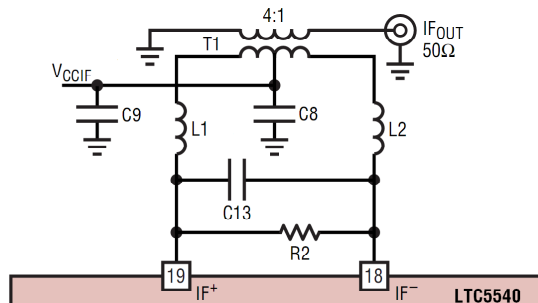

Figure 3. IF Output with Lowpass Matching

Demonstration Circuit 1431A-A's IF output can be converted to lowpass matching with minimal modifications. Follow the procedures below, and refer to Figure 4.

- Remove existing L1, L2, and C10.
- Cut the traces leading to the IF transformer close to the pads of L1 and L2.
- Insert series inductors on the cut traces.
- Install a 0Ω jumper between the pads of C8 and C10.
- Install R2 at location R2.
- Install C13 next to, or on top of, R2.

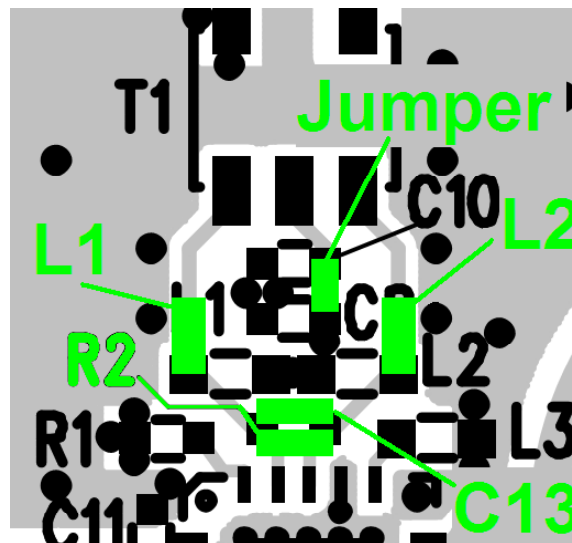

Figure 4. Modifications for Lowpass Matching

MEASUREMENT EQUIPMENT AND SETUP

The LTC5540 is a high dynamic range downconverting mixer IC with very high input 3rd order intercept. Accuracy of its performance measurement is highly dependent on equipment setup and measurement technique. The recommended measurement setups are presented in Figure 5, Figure 6, and Figure 7. The following precautions should be observed:

1. Use high performance signal generators with low harmonic output and low phase noise, such as the Rohde & Schwarz SME06. Filters at the signal generators' outputs may also be used to suppress higher-order harmonics.
2. A high quality RF power combiner that provide broadband 50 Ω -termination on all ports and have good port-to-port isolation should be used, such as the MCLI PS2-17.
3. Use high performance amplifiers with high IP3 and high reverse isolation, such as the Mini-Circuits ZHL-1042J, on the outputs of the RF signal generators to improve source isolation to prevent the sources from modulating each other and generating intermodulation products.
4. Use attenuator pads with good VSWR on the demonstration circuit's input and output ports to improve source and load match to reduce reflections, which may degrade measurement accuracy.
5. A high dynamic range spectrum analyzer, such as the Rohde & Schwarz FSEM30 should be used for linearity measurement.
6. Use narrow resolution bandwidth (RBW) and engage video averaging on the spectrum analyzer to lower the displayed average noise level (DANL) in order to improve sensitivity and to increase dynamic range. However, the trade off is increased sweep time.
7. Spectrum analyzers can produce significant internal distortion products if they are over-driven. Generally, spectrum analyzers are designed to operate at their best with about -30dBm at their input filter or preselector. Sufficient spectrum analyzer input attenuation should be used to avoid saturating the instrument, but too much attenuation reduces sensitivity and dynamic range.
8. Before taking measurements, the system performance should be evaluated to ensure that:
 - a. Clean input signals can be produced. The two-tone signals' OIP3 should be at least 15dB better than the DUT's IIP3.
 - b. The spectrum analyzer's internal distortion is minimized.
 - c. The spectrum analyzer has enough dynamic range and sensitivity. The measurement system's IIP3 should be at least 15dB better than the DUT's OIP3.
 - d. The system is accurately calibrated for power and frequency.

A SPECIAL NOTE ABOUT RF TERMINATION

The LTC5540 consists of a high linearity passive double-balanced mixer core and IF buffer amplifier. Due to the bi-directional nature of all passive mixers, LO \pm IF mixing product is always present at the RF input, typically at a level of 12dB below the RF input signal. If the LO \pm IF "Pseudo-Image Spur" is not properly terminated, it may interfere with the source signals, and can degrade the measured linearity and noise figure significantly. To avoid interference from the LO \pm IF "Pseudo-Image Spur", terminate the RF input port with an isolator, diplexer, or attenuator. In the recommended measurement setups presented in Figure 6 and Figure 7, the 6dB attenuator pad at the demonstration circuit's RF input serves this purpose.

QUICK START PROCEDURE

Demonstration circuit 1431A-A is easy to set up to evaluate the performance of the LTC5540. Refer to Figure 5, Figure 6, and Figure 7 for proper equipment connections and follow the procedure below:

NOTE. Care should be taken to never exceed absolute maximum input ratings. Make all connections with RF and DC power off.

RETURN LOSS MEASUREMENTS

1. Configure the Network Analyzer for return loss measurement, set appropriate frequency range, and set the test signal to -3dBm.
2. Calibrate the Network Analyzer.
3. Connect all test equipment as shown in Figure 5 with the signal generator and the DC power supply turned off.
4. Increase VCC supply voltage to 3.3V, and verify that the current consumption is approximately 193mA with the LO signal applied. The supply voltage should be confirmed at the demo board VCC and GND terminals to account for lead ohmic losses.
5. With the LO signal applied, and the unused demo board ports terminated in 50Ω, measure return losses of the RF input and IF output ports.
6. Set the test signal to 0dBm, and re-calibrate the Network Analyzer.
7. Terminate the RF input, the IF output, and the unused LO port in 50Ω. Measure return losses of the LO input ports.

RF PERFORMANCE MEASUREMENTS

1. Connect all test equipment as shown in Figure 6 with the signal generators and the DC power supply turned off.
2. Increase VCC supply voltage to 3.3V, and verify that the current consumption is approximately 193mA with the LO signal applied. The supply voltage should be confirmed at the

demo board VCC and GND terminals to account for lead ohmic losses.

3. Set the LO source (Signal Generator 1) to provide a 0dBm, CW signal to the selected demo board LO input port at appropriate LO frequency.
4. Set the RF sources (Signal Generators 2 and 3) to provide two -3dBm CW signals, 2MHz apart, to the demo board RF input port at the appropriate RF frequency.
5. Measure the resulting IF output on the Spectrum Analyzer:
 - a. The wanted two-tone IF output signals are at:

$$f_{IF1} = f_{RF1} - f_{LO}, \text{ and}$$

$$f_{IF2} = f_{RF2} - f_{LO} \text{ for low-side LO,}$$
 and

$$f_{IF1} = f_{LO} - f_{RF1}, \text{ and}$$

$$f_{IF2} = f_{LO} - f_{RF2} \text{ for high-side LO}$$
 - b. The 3rd order intermodulation products which are closest to the wanted IF signals are used to calculate the Input 3rd Order Intercept:

$$f_{IM3,1} = f_{RF1} - f_{LO} - \Delta_{IF}, \text{ and}$$

$$f_{IM3,2} = f_{RF2} - f_{LO} + \Delta_{IF} \text{ for low-side LO,}$$
 and

$$f_{IM3,1} = f_{LO} - f_{RF1} + \Delta_{IF}, \text{ and}$$

$$f_{IM3,2} = f_{LO} - f_{RF2} - \Delta_{IF} \text{ for high-side LO}$$
 Where $\Delta_{IF} = f_{RF2} - f_{RF1}$.
6. Calculate Input 3rd Order Intercept:

$$IIP3 = (\Delta_{IM3})/2 + P_{RF}$$

Where $\Delta_{IM3} = P_{IF} - P_{IM3}$. P_{IF} is the lowest IF output signal power at either f_{IF1} or f_{IF2} . P_{IM3} is the highest 3rd order intermodulation product power at either $f_{IM3,1}$ or $f_{IM3,2}$. P_{RF} is the per-tone RF input power.

7. Turn off one of the RF signal generators, and measure Conversion Gain, RF to IF isolation, LO to IF leakage, and Input 1dB compression point.

NOISE FIGURE MEASUREMENT

1. Configure and calibrate the noise figure meter for mixer measurements.
2. Connect all test equipment as shown in Figure 7 with the signal generator and the DC power supply turned off.
3. Increase VCC supply voltage to 3.3V, and verify that the current consumption is approximately 193mA with the LO signal applied. The supply voltage should be confirmed at the demo board VCC and GND terminals to account for lead ohmic losses.
4. Measure the single-sideband noise figure.

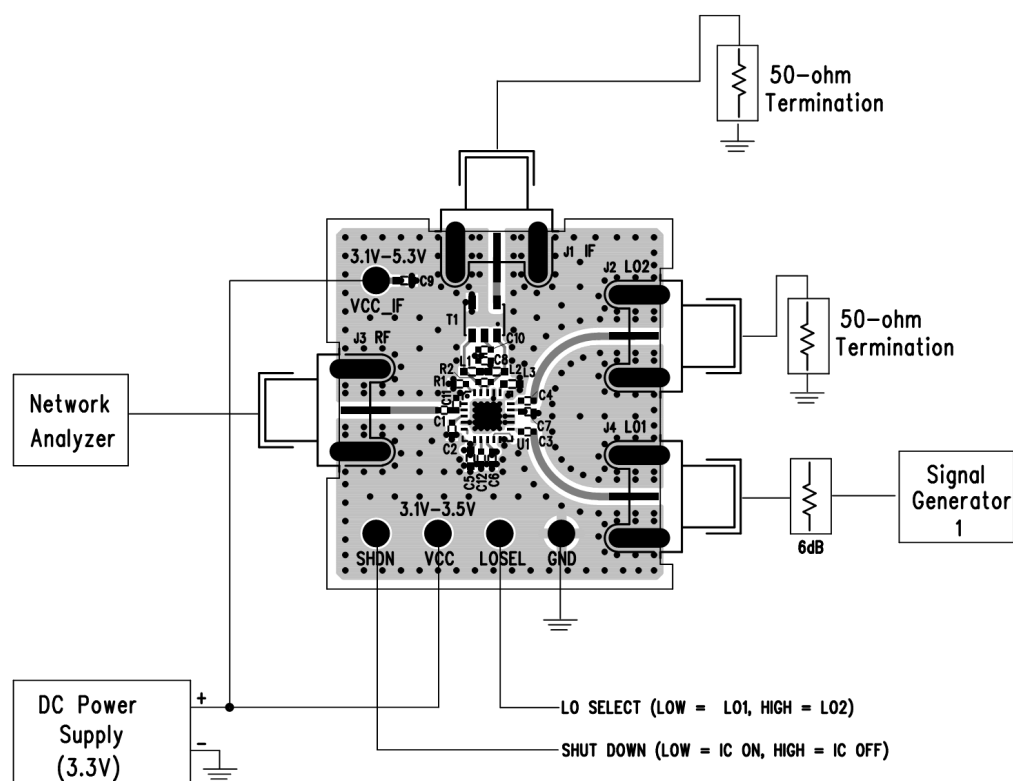

Figure 5. Proper Equipment Setup for Return Loss Measurements

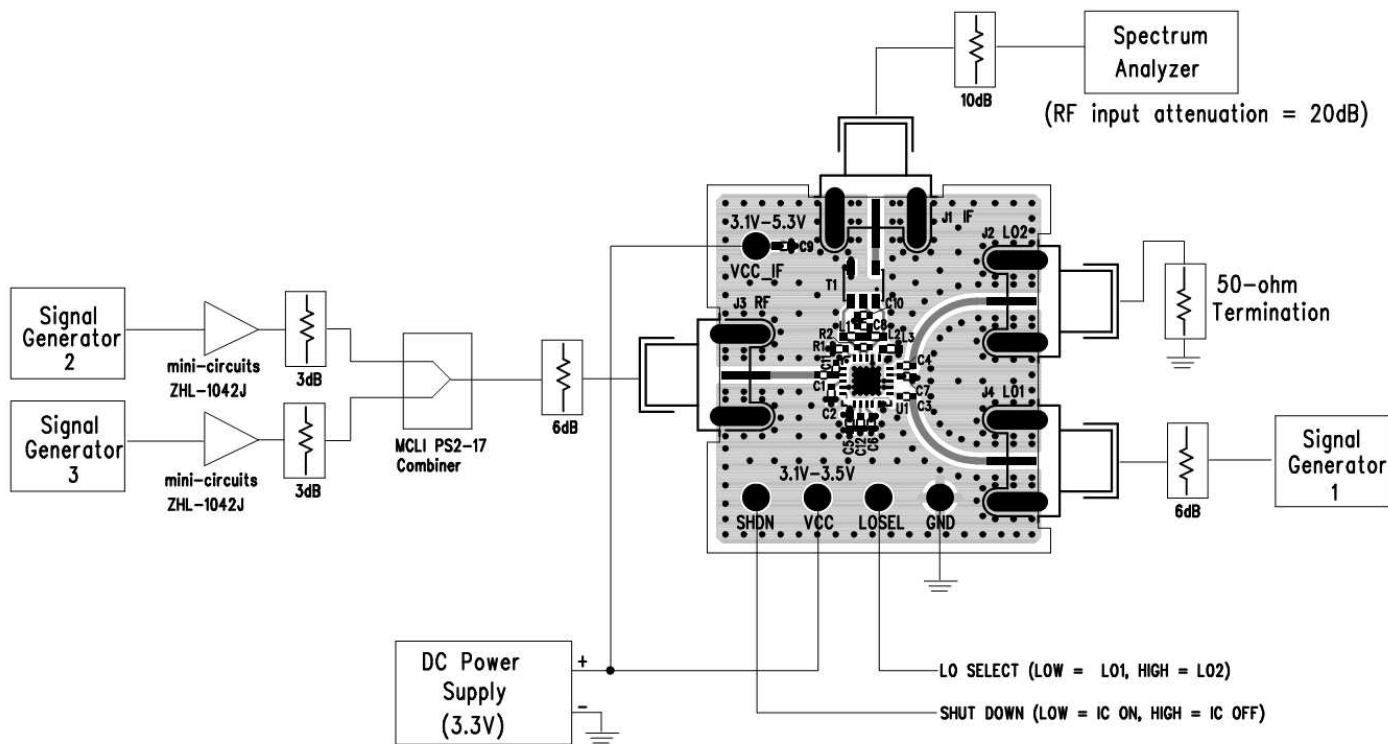

Figure 6. Proper Equipment Setup for RF Performance Measurements

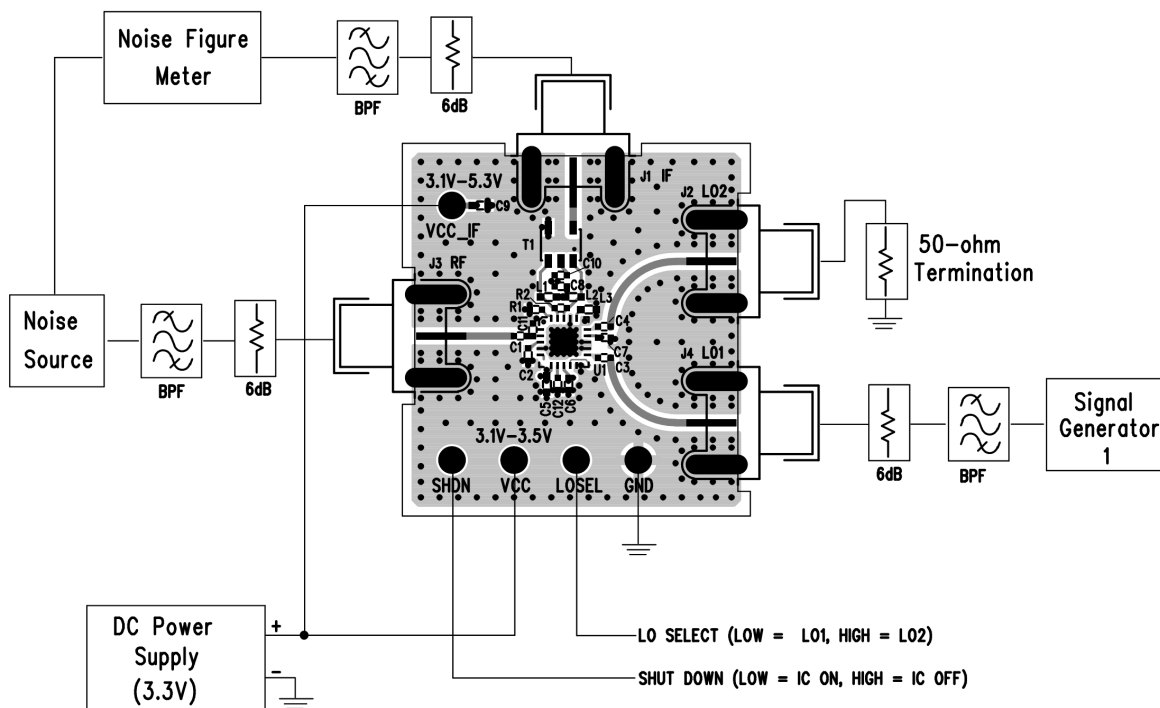

Figure 7. Proper Equipment Setup for Noise Figure Measurement

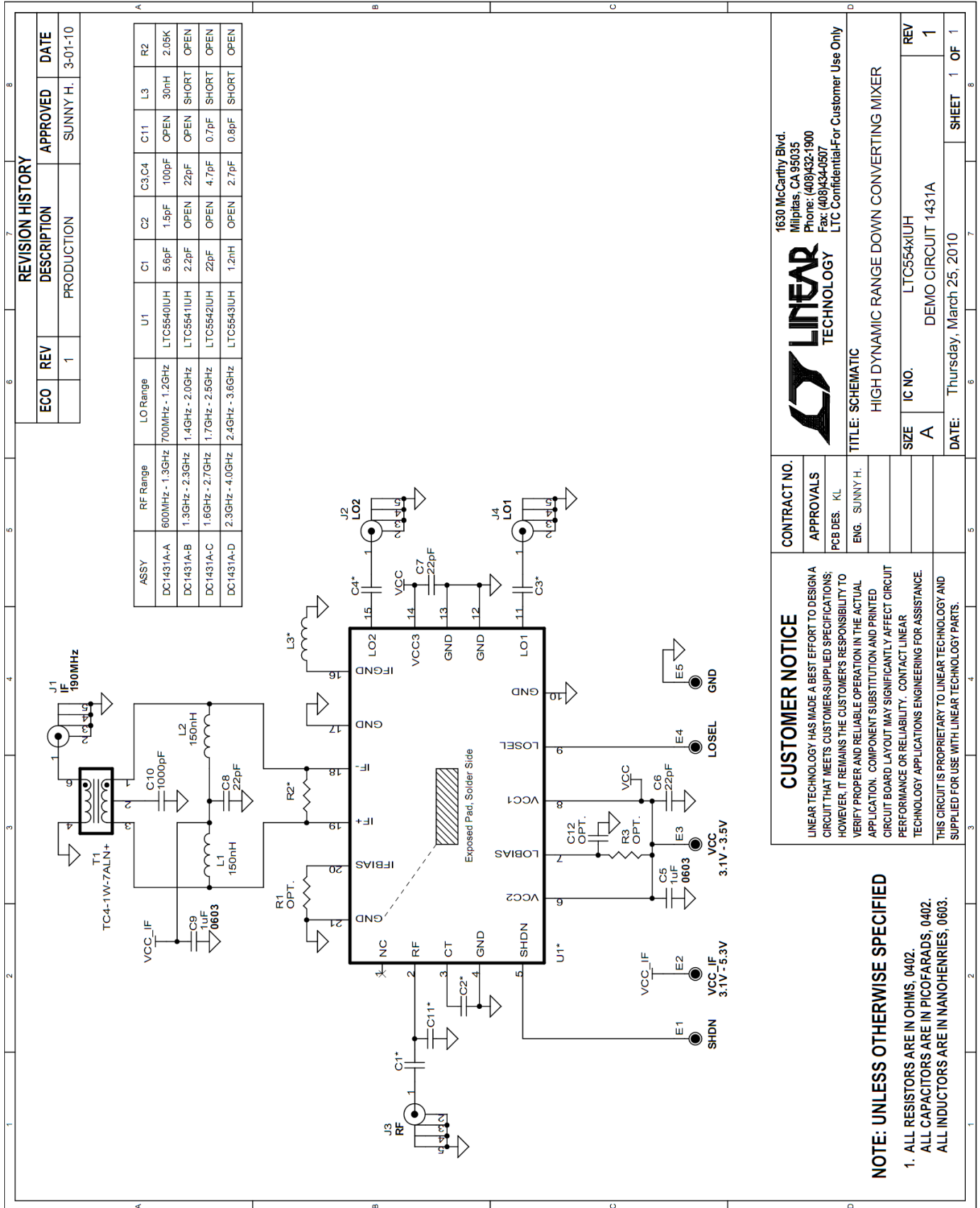

Figure 8. Demonstration Circuit schematic

CONTRACT NO.

APPROVALS

PCB DES: KL

ENG: SUNNY H.

1630 McCarthy Blvd.
Milpitas, CA 95035
Phone: (408)432-1900
Fax: (408)434-0507
LTC Confidential/For Customer Use Only

LINEAR TECHNOLOGY

TITLE: SCHEMATIC

HIGH DYNAMIC RANGE DOWN CONVERTING MIXER

CUSTOMER NOTICE

LINEAR TECHNOLOGY HAS MADE A BEST EFFORT TO DESIGN A CIRCUIT THAT MEETS CUSTOMER-SUPPLIED SPECIFICATIONS; HOWEVER, IT REMAINS THE CUSTOMER'S RESPONSIBILITY TO VERIFY PROPER AND RELIABLE OPERATION IN THE ACTUAL APPLICATION. COMPONENT SUBSTITUTION AND PRINTED CIRCUIT BOARD LAYOUT MAY SIGNIFICANTLY AFFECT CIRCUIT PERFORMANCE OR RELIABILITY. CONTACT LINEAR TECHNOLOGY APPLICATIONS ENGINEERING FOR ASSISTANCE.

THIS CIRCUIT IS PROPRIETARY TO LINEAR TECHNOLOGY AND SUPPLIED FOR USE WITH LINEAR TECHNOLOGY PARTS.

NOTE: UNLESS OTHERWISE SPECIFIED

1. ALL RESISTORS ARE IN OHMS, 0402.
ALL CAPACITORS ARE IN PICOFARADS, 0402.
ALL INDUCTORS ARE IN NANOHENRIES, 0603.

SIZE: A

IC NO.: LTC554xIUH

DATE: Thursday, March 25, 2010

REV: 1

DEMO CIRCUIT 1431A

SHEET 1 OF 1