



Chipsmall Limited consists of a professional team with an average of over 10 year of expertise in the distribution of electronic components. Based in Hongkong, we have already established firm and mutual-benefit business relationships with customers from,Europe,America and south Asia,supplying obsolete and hard-to-find components to meet their specific needs.

With the principle of “Quality Parts,Customers Priority,Honest Operation,and Considerate Service”,our business mainly focus on the distribution of electronic components. Line cards we deal with include Microchip,ALPS,ROHM,Xilinx,Pulse,ON,Everlight and Freescale. Main products comprise IC,Modules,Potentiometer,IC Socket,Relay,Connector.Our parts cover such applications as commercial,industrial, and automotives areas.

We are looking forward to setting up business relationship with you and hope to provide you with the best service and solution. Let us make a better world for our industry!



Contact us

Tel: +86-755-8981 8866 Fax: +86-755-8427 6832

Email & Skype: info@chipsmall.com Web: www.chipsmall.com

Address: A1208, Overseas Decoration Building, #122 Zhenhua RD., Futian, Shenzhen, China



5A, Low Noise, Programmable Output, 85mV Dropout Linear Regulator with Analog Margin

DESCRIPTION

Demonstration circuit 1434 is an adjustable 5A linear regulator featuring LT3071. LT3071 is a low dropout voltage, UltraFast™ transient response linear regulator. The device supplies up to 5A of output current with a typical dropout voltage of 85mV. A 0.01μF reference bypass capacitor decreases output voltage noise to 25μV_{RMS}. The LT3071's high bandwidth permits the use of low ESR ceramic capacitors.

Output voltage is digitally selectable in 50mV increments over a 0.8V to 1.8V range. An analog margining function allows the user to adjust system output voltage over a continuous ±10% range. To maintain proper performance and regulation, the BIAS supply voltage must be higher than the IN supply voltage. For a given V_{OUT}, the BIAS voltage must satisfy the following conditions:

$$2.2 \leq V_{BIAS} \leq 3.6V \text{ and } V_{BIAS} \geq (1.25 \cdot V_{OUT} + 1V).$$

For V_{OUT} ≤ 0.95V, the minimum bias voltage is limited to 2.2V.

The IC incorporates a unique tracking function to control buck regulator powering the LT3071's input. This tracking function drives the buck regulator to maintain the LT3071's input voltage to V_{OUT} + 300mV, minimizing power dissipation. It has internal protection includes UVLO, reverse-current protection, precision current limiting with power fold-back and thermal shutdown.

The LT3071 regulator is available in a thermally enhanced 28-lead, 4mm×5mm QFN package.

The LT3071 datasheet gives a complete description of the part, operation and application information. The datasheet must be read in conjunction with this quick start guide for demo circuit 1434.

Design files for this circuit board are available. Call the LTC factory.

LT, LTC and LT are registered trademarks of Linear Technology Corporation. UltraFast is a trade mark of Linear Technology Corporation. All other trademarks are the property of their respective owners.

Performance Summary (T_A = 25°C)

PARAMETER	CONDITION	VALUE
Minimum Input Voltage	V _{OUT} =1.2V, I _{OUT} = 5A	1.32V
Maximum Input Voltage		3V
Minimum Bias Voltage	V _{OUT} =1.2V	2.5V
Maximum Bias Voltage		3.6V
Output Voltage V _{OUT}	JP1=LOW, JP2=HIGH, JP3=HIGH	1.2V ±1%
Maximum Output Current	V _{IN} - V _{out} < 0.5V	5A

QUICK START PROCEDURE

Demonstration circuit 1434 is easy to set up to evaluate the performance of the LT3071. Refer to Figure 1 for proper measurement equipment setup and follow the procedure below:

1. Place JP5 on the ON position.

2. Use JP1, JP2, JP3 and MAGRA voltage to set the desired output voltage.
3. With power off, connect the input power supply to Vin and GND.
4. Connect the bias voltage to Vbias and GND.
5. Turn on the power at the input and the bias pin.
6. Check for the proper output voltage.
7. Once the proper output voltage is established, adjust the load within the operating range and observe the output voltage regulation, efficiency and other parameters.

NOTE . Make sure that the input voltage does not exceed 3V and the bias voltage is within its limit.

6. Check for the proper output voltage.

NOTE . If there is no output, temporarily disconnect the load to make sure that the load is not set too high.

NOTE . Make sure that the power dissipation is limited below the thermal limit.

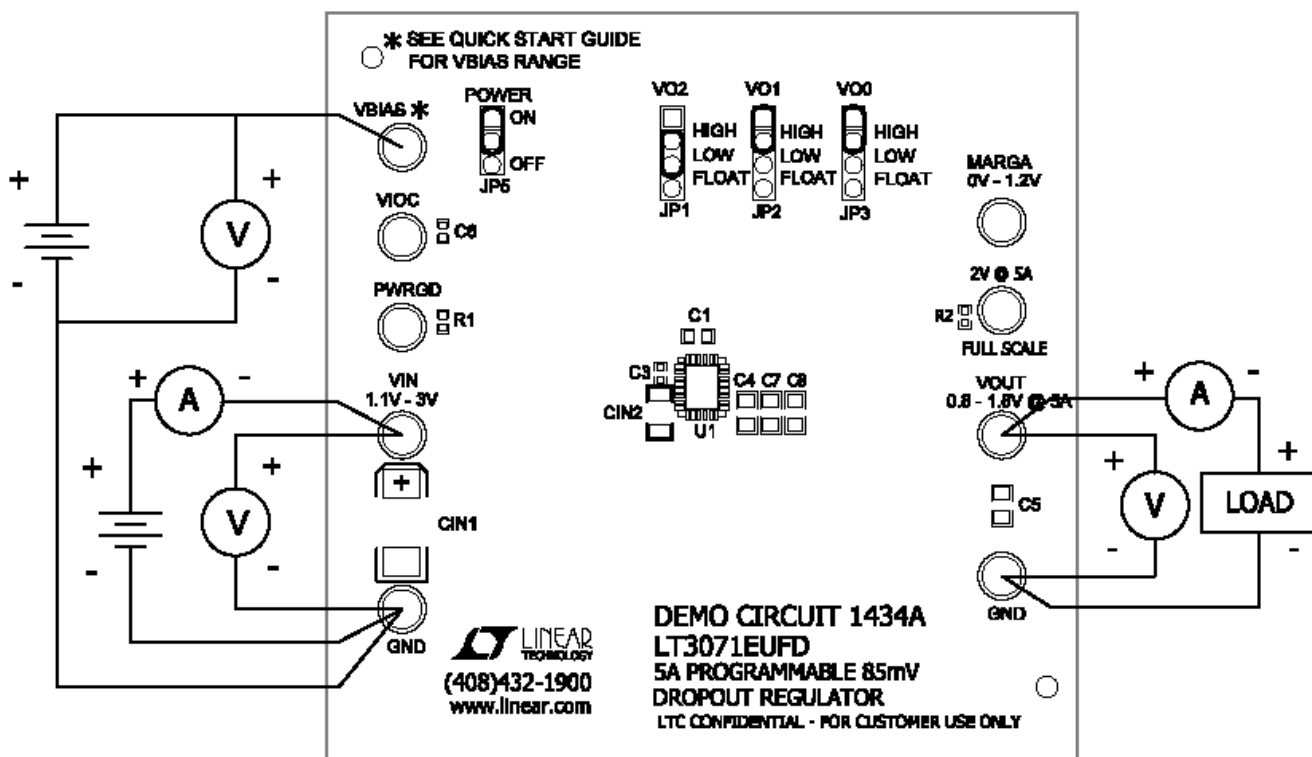

Figure 1. Proper Measurement Equipment Setup

* SEE QUICK START GUIDE
FOR VBIAS RANGE

