



Chipsmall Limited consists of a professional team with an average of over 10 year of expertise in the distribution of electronic components. Based in Hongkong, we have already established firm and mutual-benefit business relationships with customers from,Europe,America and south Asia,supplying obsolete and hard-to-find components to meet their specific needs.

With the principle of "Quality Parts,Customers Priority,Honest Operation,and Considerate Service",our business mainly focus on the distribution of electronic components. Line cards we deal with include Microchip,ALPS,ROHM,Xilinx,Pulse,ON,Everlight and Freescale. Main products comprise IC,Modules,Potentiometer,IC Socket,Relay,Connector.Our parts cover such applications as commercial,industrial, and automotives areas.

We are looking forward to setting up business relationship with you and hope to provide you with the best service and solution. Let us make a better world for our industry!



Contact us

Tel: +86-755-8981 8866 Fax: +86-755-8427 6832

Email & Skype: info@chipsmall.com Web: www.chipsmall.com

Address: A1208, Overseas Decoration Building, #122 Zhenhua RD., Futian, Shenzhen, China



DESCRIPTION

Demonstration circuit 1492 features the LTC2462, a 16 bit high performance $\Delta\Sigma$ analog-to-digital converter (ADC) with an SPI interface. The input is bipolar with a range of $\pm \text{REF}/2$. The modulator's proprietary sampling technique reduces the average input current to less than 50nA – orders of magnitude lower than typical delta sigma ADCs.

DC1492 is a member of Linear Technology's QuickEval™ family of demonstration boards. It is designed to allow easy evaluation of the LTC2462 and may be connected directly to the target application's analog signals while using

the DC590 USB Serial Controller board and supplied software to measure performance. The exposed ground planes allow proper grounding to prototype circuitry. After evaluating with Linear Technology's software, the digital signals can be connected to the end application's processor / controller for development of the serial interface.

Design files for this circuit board are available. Call the LTC factory.

LTC is a trademark of Linear Technology Corporation

Figure 1. Proper Measurement Equipment Setup

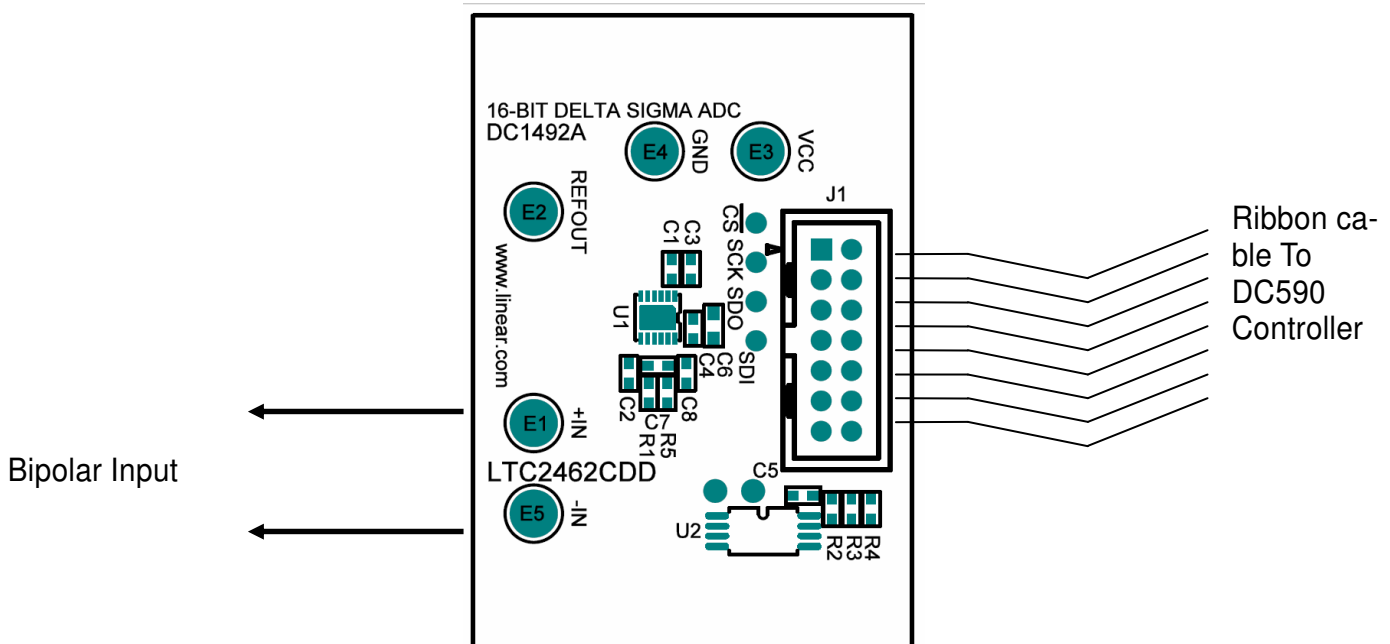

QUICK START PROCEDURE

Connect DC1492 to a DC590 USB Serial Controller using the supplied 14 conductor ribbon cable. Connect DC590 to host PC with a standard USB A/B cable. Run the evaluation software supplied with DC590 or downloaded from <http://www.linear.com/software>. The correct program will be loaded automatically. Click the COLLECT button to start reading the input volt-

age. Details on software features are documented in the control panel's help menu.

Tools are available for logging data, changing reference voltage, changing the number of points in the strip chart and histogram, and changing the number of points averaged for the DVM display.

Figure 2. Software Screenshot

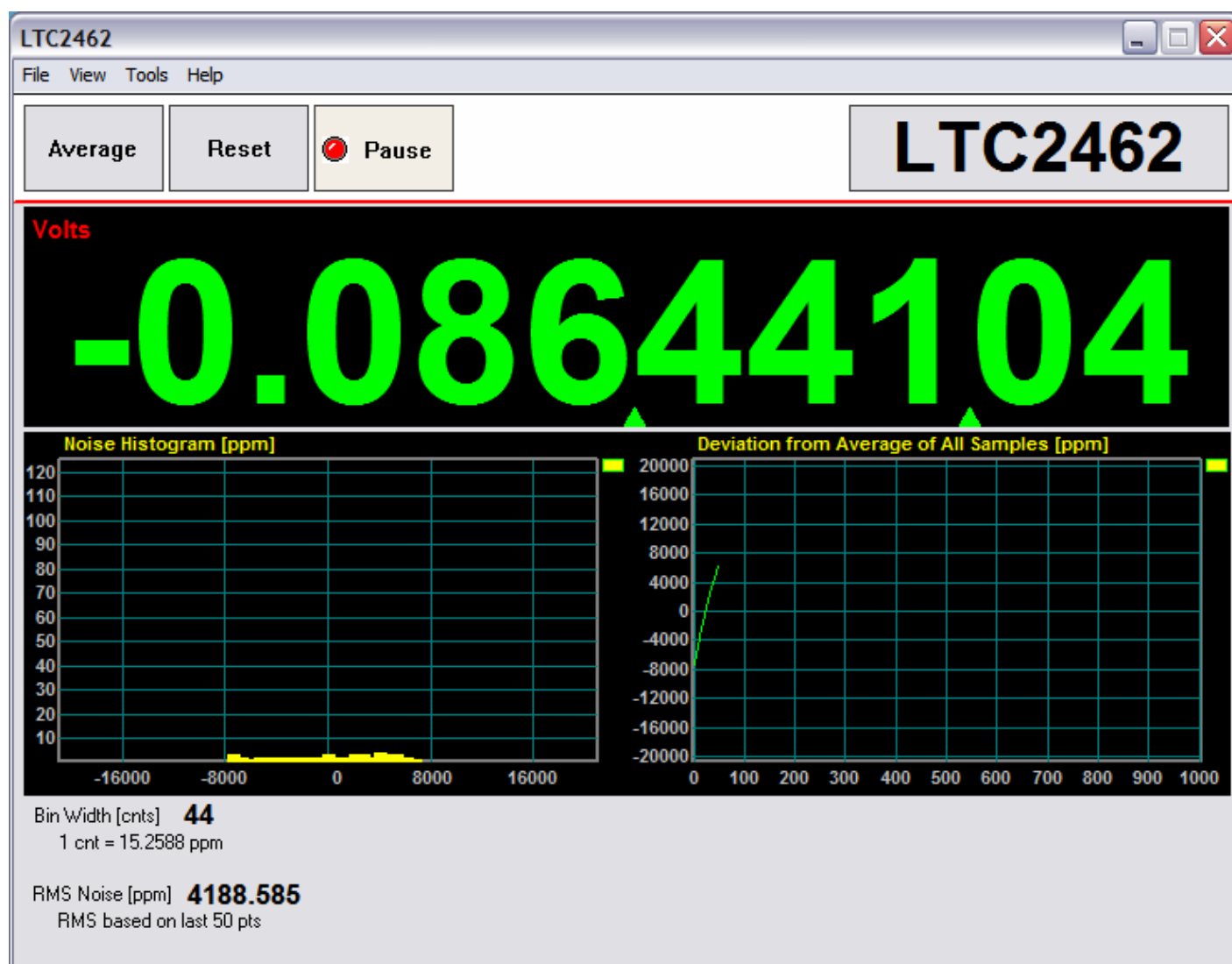

HARDWARE SET-UP

CONNECTION TO DC590 SERIAL CONTROLLER

J1 is the power and digital interface connector. Connect to DC590 serial controller with supplied 14 conductor ribbon cable.

ANALOG CONNECTIONS

Analog signal connections are made via the row of turret posts along the edge of the board. Also, when connecting the board to an existing circuit the exposed ground planes along the edges of the board may be used to form a solid connection between grounds.

GND – This turret is connected directly to the internal ground planes.

VCC – This is the supply and reference voltage for the ADC. Do not draw any power from this point.

IN+ – This is the positive input to the ADC

IN- – This is the negative input to the ADC.

Refout – This turret is used as the reference voltage for the LTC2462.

QUICK START GUIDE FOR DEMONSTRATION CIRCUIT 1492 16 BIT, DIFFERENTIAL, DELTA SIGMA ADC WITH SPI INTERFACE

