



Chipsmall Limited consists of a professional team with an average of over 10 year of expertise in the distribution of electronic components. Based in Hongkong, we have already established firm and mutual-benefit business relationships with customers from,Europe,America and south Asia,supplying obsolete and hard-to-find components to meet their specific needs.

With the principle of “Quality Parts,Customers Priority,Honest Operation,and Considerate Service”,our business mainly focus on the distribution of electronic components. Line cards we deal with include Microchip,ALPS,ROHM,Xilinx,Pulse,ON,Everlight and Freescale. Main products comprise IC,Modules,Potentiometer,IC Socket,Relay,Connector.Our parts cover such applications as commercial,industrial, and automotives areas.

We are looking forward to setting up business relationship with you and hope to provide you with the best service and solution. Let us make a better world for our industry!



## Contact us

Tel: +86-755-8981 8866 Fax: +86-755-8427 6832

Email & Skype: info@chipsmall.com Web: www.chipsmall.com

Address: A1208, Overseas Decoration Building, #122 Zhenhua RD., Futian, Shenzhen, China



## LTC2393-16/LTC2392-16/ LTC2391-16: 16-Bit, 1MSPS/ 0.5MSPS/0.25MSPS Low Noise ADCs

### DESCRIPTION

The LTC<sup>®</sup>2393/LTC2392/LTC2391-16 are low noise high speed ADCs with both parallel and serial outputs that can operate from a single 5V supply. The following text refers to the LTC2393-16 but applies to all three parts. The only difference being the maximum sample rates. The LTC2393-16 supports a large  $\pm 4.096V$  fully differential input range. This makes it ideal for high performance applications that require maximum dynamic range. Demonstration circuit 1500A provides the user a means of evaluating the

performance of the LTC2393-16 in both parallel and serial modes and is intended to demonstrate recommended grounding, component placement and selection, routing and bypassing for this ADC. Also several suggested driver circuits for the analog inputs will be presented.

**Design files for this circuit board are available at [www.linear.com/demo](http://www.linear.com/demo).**

LT, LTC, LTM, Linear Technology and the Linear logo are registered trademarks of Linear Technology Corporation. All other trademarks are the property of their respective owners.

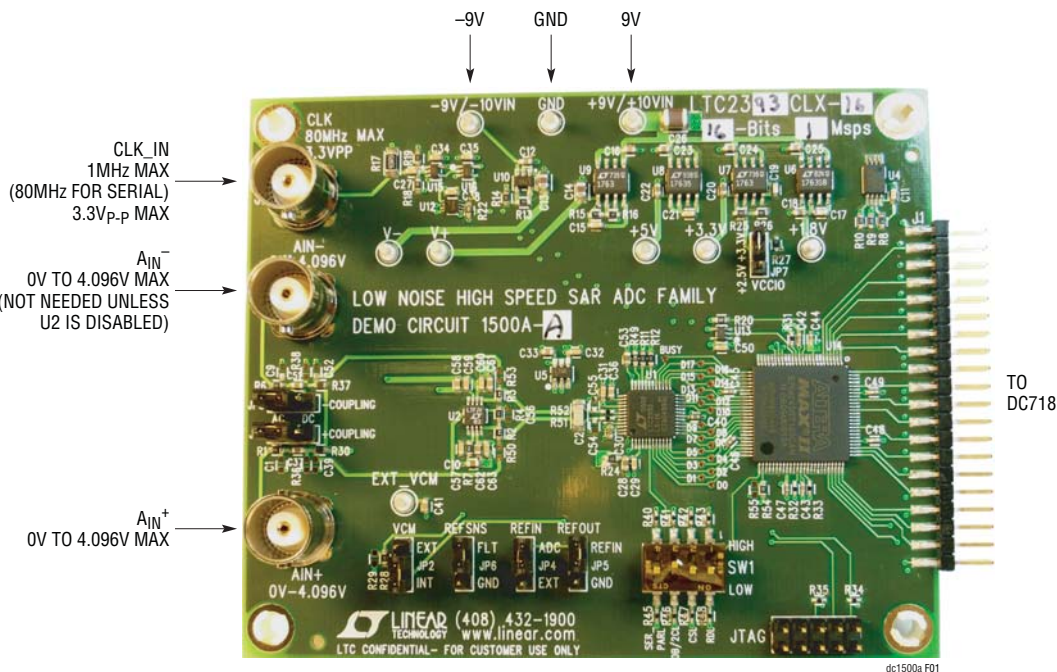

Figure 1. DC1500A Connection Diagram

Table 1

ASSEMBLY VERSION	PART NUMBER	MAX CONVERSION RATE	MAX PARALLEL CLK IN FREQUENCY	MAX SERIAL CLK IN FREQUENCY
DC1500A-A	LTC2393CLX-16	1MSPS	1MHz	80MHz
DC1500A-B	LTC2392CLX-16	0.5MSPS	500kHz	40MHz
DC1500A-C	LTC2391CLX-16	0.25MSPS	250kHz	20MHz

## QUICK START PROCEDURE

Check to make sure that all switches and jumpers are set as shown in the connection diagram of Figure 1. The default connections configure the ADC for parallel operation with the output data in offset binary format. The analog input is AC-coupled and the internal reference of the ADC is used.

Connect DC1500A to a DC718B/C USB High Speed Data Collection Board using connector J1. Connect DC718B/C to a host PC with a standard USB A/B cable. Apply  $\pm 9V$  to the indicated terminals. Apply a low jitter signal source to J3 (AIN<sup>+</sup>). The default setup uses a single ended to differential converter so that it is only necessary to apply an input signal to J3. Connect a low jitter 1MHz 3.3V<sub>P-P</sub> sine wave or square wave to connector J2 (CLK). Note that J2 has a 50 $\Omega$  termination resistor to ground.

Run the QuickEval-II software (Pscope.exe version K66 or later) supplied with DC718B/C or download it from [www.linear.com](http://www.linear.com).

Complete software documentation is available from the Help menu. Updates can be downloaded from the Tools menu. Check for updates periodically as new features may be added.

The Pscope software should recognize DC1500A and configure itself automatically.

Click the Collect button (see Figure 6) to begin acquiring data. The Collect button then changes to Pause, which can be clicked to stop data acquisition.

---

## SETUP

### DC Power

DC1500A requires  $\pm 9VDC$  at approximately 100mA. Most of the supply current is consumed by the CPLD, op amps, regulators and discreet logic on the board. The  $\pm 9VDC$  input voltage powers the ADC through LT1763 regulators which provide protection against accidental reverse bias. Additional regulators provide power for the CPLD and op amps. See Figure 1 for connection details.

### Clock Source

You must provide a low jitter 3.3V<sub>P-P</sub> sine or square wave to J2. The clock input is AC-coupled so the DC level of the clock signal is not important. A generator like the HP8644 or similar is recommended. Even a good generator can start to produce noticeable jitter at low frequencies. Therefore it is recommended for lower sample rates to divide down a higher frequency clock to the desired sample rate. One way to do this is by placing the ADC in the serial mode. This can be accomplished by setting the SER/PARL position of SW1 to the high position. In the serial mode the ratio of clock frequency to conversion rate is 80:1. In the parallel mode there is a 1:1 ratio of clock frequency to conversion rate. If the clock input is to be driven with logic, it is recommended that the 50 $\Omega$  terminator (R17)

be removed. Slow rising edges may compromise SNR of the converter in the presence of high amplitude higher frequency input signals.

### Data Output

Parallel data output from this board (0V to 3.3V default), if not connected to DC718, can be acquired by a logic analyzer, and subsequently imported into a spreadsheet, or mathematical package depending on what form of digital signal processing is desired. Alternatively, the data can be fed directly into an application circuit. Use pin 3 of J1 to latch the data. The data can be latched using either edge of this signal. The data output signal levels at J1 can also be reduced to 0V to 2.5V if the application circuit cannot tolerate the higher voltage. This is accomplished by moving JP7 to the 2.5V position.

### Reference

JP4, JP5 and JP6 allow you to select an on chip reference or an external LT1790A-4.096 as the reference. The worst case initial accuracy and drift specifications of the external reference are better than the on chip reference. To use the internal reference set JP6 to FLT, JP4 to ADC and JP5 to REFIN. To use the LT1790A-4.096 set JP5 and JP6 to GND and JP4 to EXT.

## SETUP

### Analog Input

The default driver for the analog inputs of the LTC2393-16 on DC1500A is shown in Figure 2. This circuit converts a single-ended 0V to 4.096V input signal applied at  $A_{IN}$  into a differential signal with a swing of  $\pm 4.096V$  between the  $+IN$  and  $-IN$  inputs of the ADC. In addition this circuit band limits the input frequencies to approximately 100kHz which is the useful linear bandwidth of the LTC2393-16.

Alternatively, if your application circuit produces a differential signal which can drive the ADC but you need to level shift the input signal, the circuits of Figure 3 and Figure 4 can be used. The circuit of Figure 3 AC-couples the input signal and is usable down to about 10kHz. The lower frequency limit can be extended by increasing C37 and C51. The circuit of Figure 3 can be implemented on DC1500A by putting JP1 and JP3 in the AC position and moving R2 and R3 to the R50 and R53 positions. At this point it will be necessary to drive both  $A_{IN}^+$  and  $A_{IN}^-$ . One of these RC pairs can be attached to the input of the circuit in Figure 2. This allows a single-ended input signal to be level shifted. This is the default condition for DC1500A. One of the most asked for ADC driver circuits is one that allows the input voltage to go below ground with a single supply ADC. Figure 4's input driver allows the input voltage range to go below ground. It DC-couples and level shifts the analog input at the expense of attenuating the input level by a factor of 2. The circuit of Figure 4 can be implemented on DC1500A by setting  $V_{CM}$  to External and biasing the external pin to 4.096V. Then replace R1 and R6 with 1k, put JP1 and JP3 in the DC position and move R2 and R3 to the R50 and R53 positions.

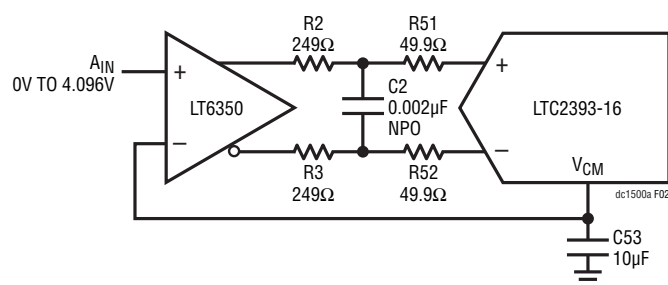

Figure 2. Single-Ended to Differential Driver

### Data Collection

For SINAD, THD or SNR testing a low noise, low distortion generator such as the B&K Type 1051 or Stanford Research DS360 should be used. A low jitter RF oscillator such as the HP8644 is used as the clock source.

This demo board is tested in house by attempting to duplicate the FFT plot shown on the front page of the LTC2393-16 data sheet. This involves using a 1MHz clock source, along with a sinusoidal generator at a frequency of 20kHz. The input signal level is approximately  $-1dBfs$ . The input is filtered with a 20kHz single pole RC filter shown in Figure 5. The FFT shown in the data sheet is a 16384-point FFT. A typical FFT obtained with DC1500A is shown in Figure 6. Note that to calculate the real SNR, the signal level (F1 amplitude =  $-1.117dB$ ) has to be added back to the SNR that PScope displays. With the example shown in Figure 6, this means that the actual SNR would be 94.237dB instead of the 93.12dB that PScope displays. Taking the RMS sum of the recalculated SNR and the THD yields a SINAD of 93.68 dB which is fairly close to the typical value for this ADC.

There are a number of scenarios that can produce misleading results when evaluating an ADC. One that is common is feeding the converter with a frequency, that is a sub-multiple of the sample rate, and which will only exercise a small subset of the possible output codes. The proper method is to pick an  $M/N$  frequency for the input sine wave frequency.  $N$  is the number of samples in the FFT.  $M$  is a prime number between one and  $N/2$ . Multiply  $M/N$  by the sample rate to obtain the input sine wave frequency. Another scenario that can yield poor results is if you do not have a signal generator capable of ppm levels of frequency accuracy or if it cannot be slaved to the clock frequency. You can use an FFT with windowing to reduce the "leakage" or spreading of the fundamental, to get a close approximation of the ADC performance. If an amplifier or clock source with poor phase noise is used, the windowing will not improve the SNR.

## SETUP

### Layout

As with any high performance ADC, this part is sensitive to layout. The area immediately surrounding the ADC on DC1500A should be used as a guideline for placement, and routing of the various components associated with the ADC. Here are some things to remember when laying out a board for the LTC2393-16. A ground plane is necessary to obtain maximum performance. Keep bypass capacitors as close to supply pins as possible. Use individual low impedance returns for all bypass capacitors. Use of a symmetrical layout around the analog inputs will minimize the effects of parasitic elements. Shield analog input traces with ground to minimize coupling from other traces. Keep traces as short as possible.

### Component Selection

When driving a low noise, low distortion ADC such as the LTC2393-16, component selection is important so as to not degrade performance. Resistors should have low values to minimize noise and distortion. Metal film resistors are recommended to reduce distortion caused by self heating. Because of their low voltage coefficients, which can reduce distortion NPO or silver mica capacitors should be used. Any buffer used to drive the LTC2393-16 should have low distortion, low noise and a fast settling time such as the LT6350.

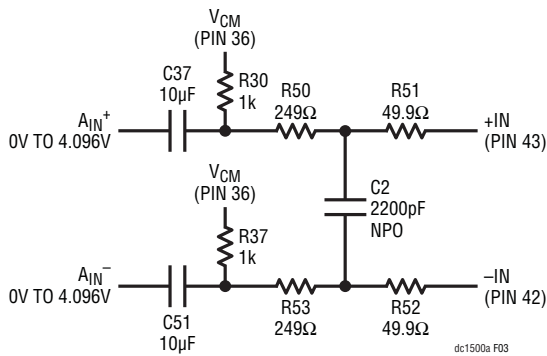

Figure 3. AC-Coupled Differential Driver

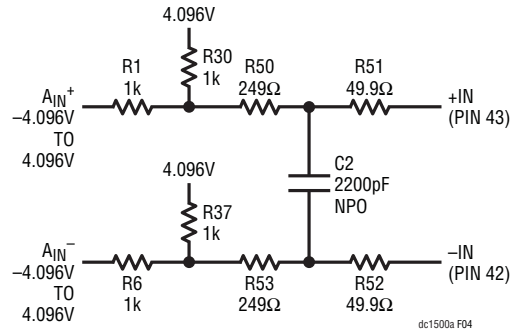

Figure 4. DC-Coupled Differential Driver

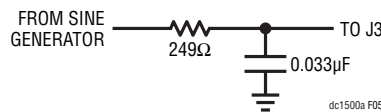

Figure 5. 20kHz RC Filter

## SETUP

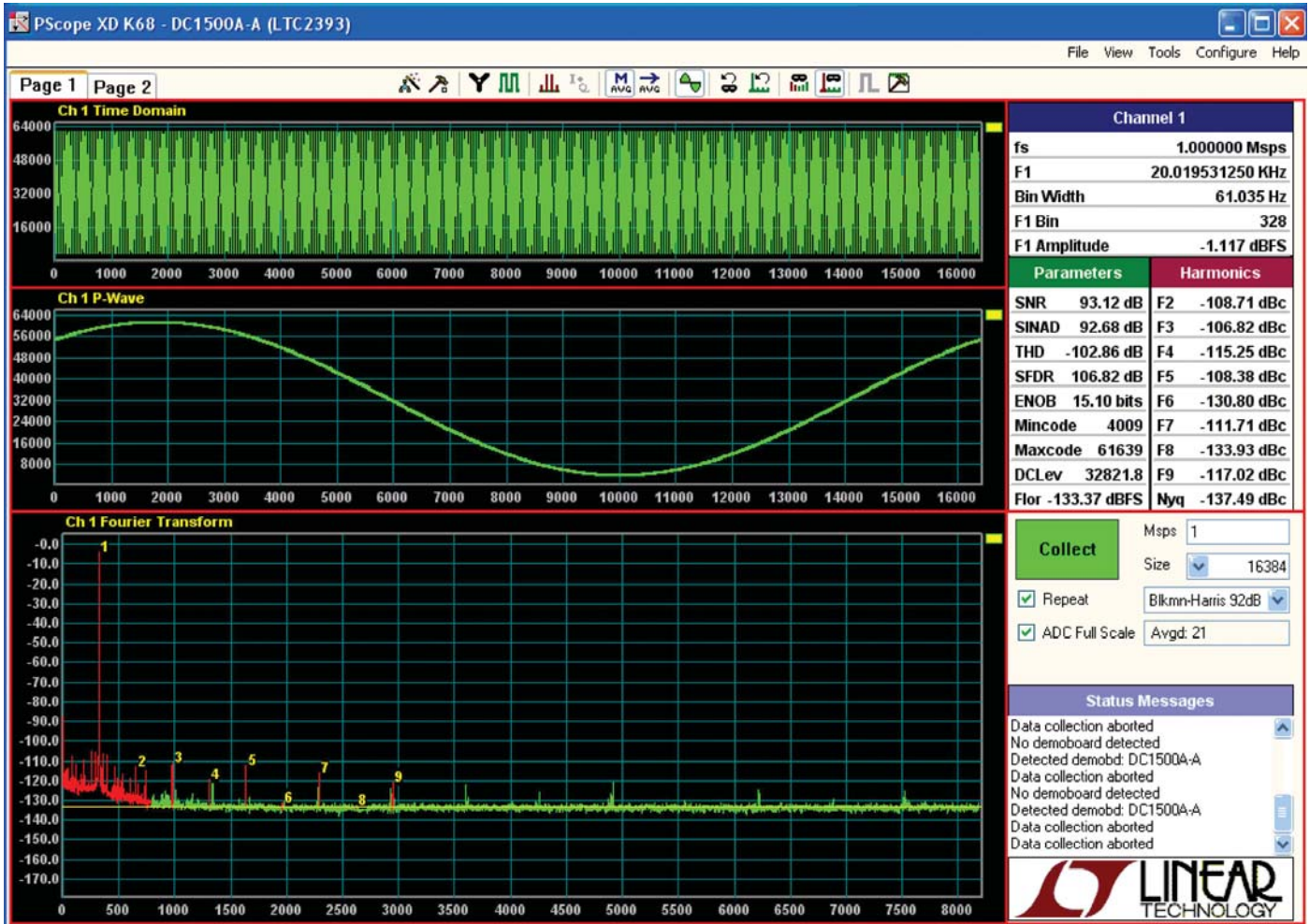

Figure 6. Pscope Screenshot

## MISCELLANEOUS DIP SWITCHES AND JUMPERS

### Definitions

**JP2:**  $V_{CM}$  sets the DC bias for  $A_{IN}^+$  and  $A_{IN}^-$  when the inputs are AC-coupled. INT is the default position.

**SW1:**

**SER\_PARL:** Selects serial or parallel operation. Default position is parallel. In parallel mode  $f_S = f_{CLK}$ . In serial mode  $f_S = f_{CLK}/80$ .

**OB/2CL:** Selects offset binary or two's complement data format for ADC output word. The default is offset binary.

**CSL:** This pin must be kept low for normal operation.

**RDL:** This pin must be kept low for normal operation.

# DEMO MANUAL DC1500A

## PARTS LIST

### LTC23xxCLX Family, DC1500A-1 General BOM

ITEM	QUANTITY	REFERENCE DESIGNATOR	DESCRIPTION	MANUFACTURERS PART NUMBER
1	0	C1, C9, C39, C52, C54, C55, C56	Capacitor, 0603	OPT
2	1	C2	Capacitor, NP0, 2200pF, 25V, 5% 1206	AVX, 12063A222JAT2A
3	9	C10, C18, C20, C22, C28, C30, C37, C51, C53	Capacitor, X5R, 10µF, 6.3V, 20% 0603	Taiyo Yuden, JMK107BJ106MA (2rls, PbF)
4	13	C11, C27, C29, C31, C32, C34, C35, C38, C50, C57, C59, C60, C63	Capacitor, X7R, 0.1µF, 25V, 10% 0603	AVX, 06033C104KAT2A
5	11	C12, C16, C23, C24, C25, C33, C36, C41, C58, C61, C62	Capacitor, X7R, 1µF, 16V, 10% 0603	AVX, 0603YC105KAT2A
6	2	C13, C14	Capacitor, X5R, 10µF, 10V, 20% 0805	Taiyo Yuden, LMK212BJ106MG
7	4	C15, C17, C19, C21	Capacitor, X7R, 0.01µF, 50V, 10% 0603	AVX, 06035C103KAT2A
8	1	C26	Capacitor, X5R, 47µF, 16V, 20% 1210	Taiyo Yuden, EMK325BJ476MM
9	1	C40	Capacitor, X5R, 4.7µF, 4V, 20% 0402	Taiyo Yuden, AMK105BJ475MV-F
10	8	C42, C43, C44, C45, C46, C47, C48, C49	Capacitor, X5R, 0.1µF, 10V, 10% 0402	AVX, 0402ZD104KAT2A
11	9	E1, E2, E3, E4, E5, E6, E7, E8, E9	Test Point, Turret, .064"	Mill-Max, 2308-2-00-80-00-00-07-0
12	6	JP1, JP2, JP3, JP4, JP5, JP6	JMP, 1 × 3, 0.1"	Samtec, TSW-103-07-L-S
13	6	Shunts On JP1 to JP6 Pins 1 and 2	Shunt, 0.1" Center	Samtec, SNT-100-BK-G
14	1	JP7	JMP, 1 × 3, 0.079CC	Samtec, TMM-103-02-L-S
15	1	Shunt On JP7 Pins 1 and 2	Shunt, 0.079" Center	Samtec, 2SN-BK-G
16	1	JTAG	Header, 2 × 5, 0.1"	Samtec, TSW-105-07-L-D
17	1	J1	Header, 0.1 × 0.1 CNTRS, 40 Pin	Samtec, TSW-120-07-L-S
18	3	J2, J3, J4	Connection, BNC, 5 Pins	Connex, 112404
19	3	R1, R4, R6	Resistor, Chip, 0Ω, 1/10W, 0603	Vishay, CRCW06030000Z0EA
20	2	R2, R3	Resistor, Chip, 249Ω, 1/10W, 1% 0603	Vishay, CRCW0603249RFKEA
21	1	R7	Resistor, Chip, 499Ω, 1/10W, 1% 0603	Vishay, CRCW0603499RFKEA
22	3	R8, R9, R10	Resistor, Chip, 4.99k, 1/10W, 1% 0603	Vishay, CRCW06034K99FKEA
23	9	R11, R12, R14, R16, R18, R19, R28, R30, R37	Resistor, Chip, 1k, 1/10W, 5% 0603	Vishay, CRCW06031K00JNEA
24	2	R13, R15	Resistor, Chip, 3.92k, 1/10W, 1% 0603	Vishay, CRCW06033K92FKEA
25	1	R17	Resistor, Chip, 49.9Ω, 1/4W, 1% 1206	Vishay, CRCW120649R9FKEA
26	3	R20, R22, R49	Resistor, Chip, 33Ω, 1/10W, 5% 0603	Vishay, CRCW060333R0JNEA
27	1	R24	Resistor, Chip, 1Ω, 1/10W, 5% 0603	Vishay, CRCW06031R00JNEA
28	1	R25	Resistor, Chip, 1.69k, 1/10W, 1% 0603	Vishay, CRCW06031K69FKEA
29	1	R26	Resistor, Chip, 1.54k, 1/10W, 1% 0603	Vishay, CRCW06031K54FKEA
30	1	R27	Resistor, Chip, 2.80k, 1/10W, 1% 0603	Vishay, CRCW06032K80FKEA
31	0	R29, R36, R38, R50, R53, R55	Resistor, Chip, 0603	OPT
32	4	R31, R32, R33, R34	Resistor, Chip, 1k, 1/16W, 5% 0402	Vishay, CRCW04021K00JNED
33	5	R35, R40, R41, R42, R43	Resistor, Chip, 10k, 1/16W, 5% 0402	Vishay, CRCW040210K0JNED
34	4	R45, R46, R47, R48	Resistor, Chip, 300Ω, 1/16W, 5% 0402	Vishay, CRCW0402300RJNED
35	2	R51, R52	Resistor, Chip, 49.9Ω, 1/16W, 1% 0402	Vishay, CRCW040249R9FKED
36	1	R54	Resistor, Chip, 10k, 1/10W, 5% 0603	Vishay, CRCW060310K0JNEA

## PARTS LIST

ITEM	QUANTITY	REFERENCE DESIGNATOR	DESCRIPTION	MANUFACTURERS PART NUMBER
37	1	SW1	Switch, 219-4MST	CTS Electronic Components, 219-4MST
38	1	U2	IC., LT6350CMS8, MS8	Linear Tech., LT6350CMS8
39	1	U4	IC., 24LC025, TSSOP-8	Microchip, 24LC025-T/ST
40	1	U5	IC., LT1790ACS6-4.096, SOT23-6	Linear Tech., LT1790ACS6-4.096#PBF
41	1	U6	IC., LT1763CS8-1.8, SO8	Linear Tech., LT1763CS8-1.8#PBF
42	2	U7, U9	IC., LT1763CS8, SO8	Linear Tech., LT1763CS8#PBF
43	1	U8	IC., LT1763CS8-5, SO8	Linear Tech., LT1763CS8-5#PBF
44	1	U10	IC., LT1964ES5-SD, SOT23-5	Linear Tech., LT1964ES5-SD#PBF
45	1	U12	IC., NL17SZ74, US8	On Semi., NL17SZ74USG
46	1	U13	IC., NC7ST04P5X, SC70-5t	Fairchild, NC7ST04P5X
47	1	U14	IC., EPM240GT100C5N, TQFP100	Altera Corp., EPM240GT100C5N
48	1	U15	IC., NC7SZ04P5X, SC70-5	Fairchild, NC7SZ04P5X
49	1	U16	IC., NC7SVU04P5X, SC70-5	Fairchild, NC7SVU04P5X
50	4	Stand-Off at 4 Corners	Stand-Off, Nylon 0.25"	Keystone, 8831(SNAP ON)
51	1		Stencil for Top Side Only	DC1500A-1

### LTC2393CLX Family, Demo Circuit 1500A-A

ITEM	QUANTITY	REFERENCE DESIGNATOR	DESCRIPTION	MANUFACTURERS PART NUMBER
1	1	DC1500A-1	General BOM	
2	1	U1	IC., LTC2393CLX-16, LQFP48-7X7	Linear Tech., LTC2393CLX-16#PBF

### LTC2392CLX-16, Demo Circuit 1500A-B

ITEM	QUANTITY	REFERENCE DESIGNATOR	DESCRIPTION	MANUFACTURERS PART NUMBER
1	1	DC1500A-1	General BOM	
2	1	U1	IC., LTC2392CLX-16, LQFP48-7X7	Linear Tech., LTC2392CLX-16#PBF

### LTC2391CLX-16, Demo Circuit 1500A-C

ITEM	QUANTITY	REFERENCE DESIGNATOR	DESCRIPTION	MANUFACTURERS PART NUMBER
1	1	DC1500A-1	General BOM	
2	1	U1	IC., LTC2391CLX-16, LQFP48-7X7	Linear Tech., LTC2391CLX-16#PBF



SCHEMATIC DIAGRAM  
DEMO MANUAL DC1500A

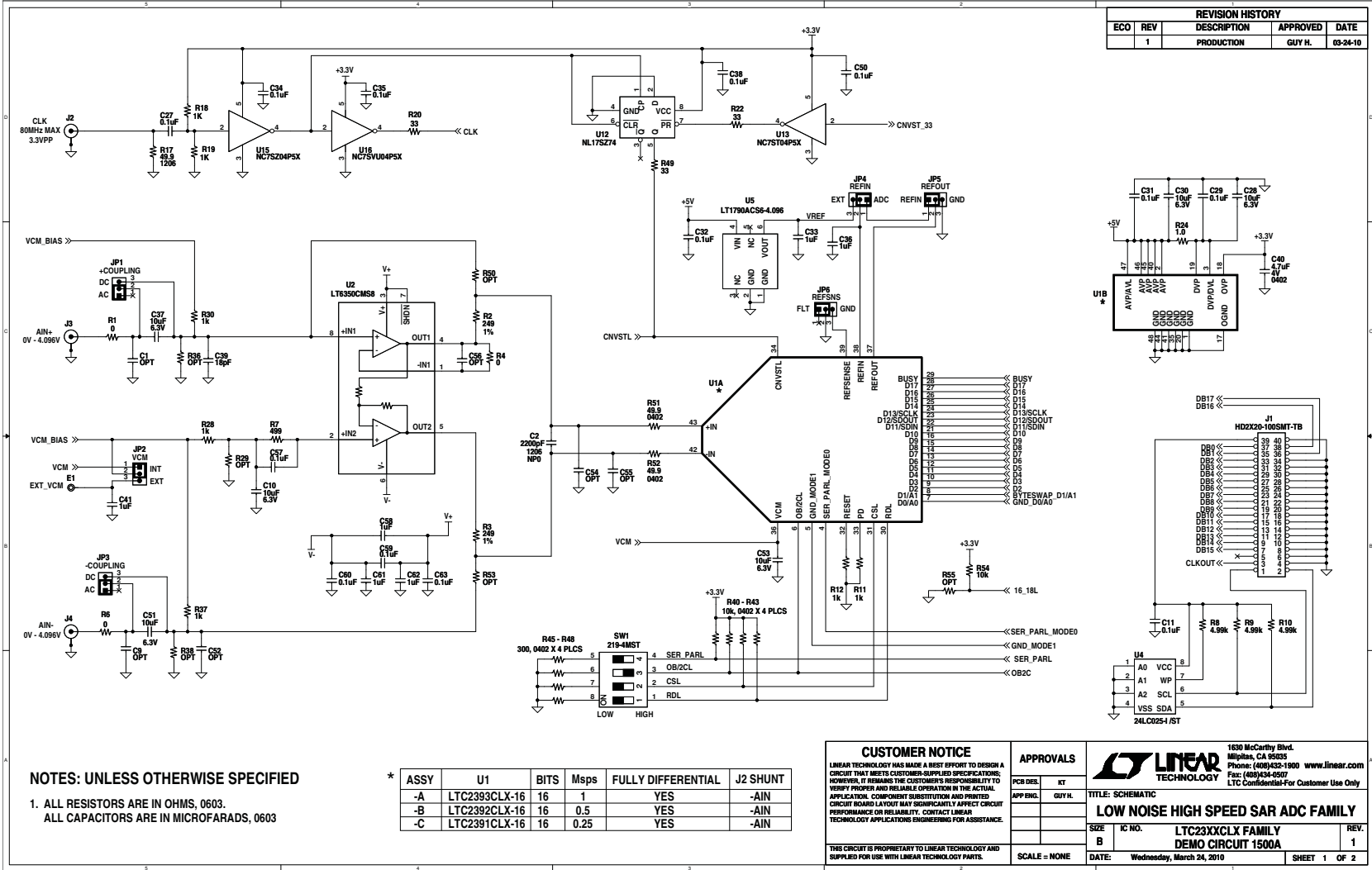

REVISION HISTORY				
ECO	REV	DESCRIPTION	APPROVED	DATE
	1	PRODUCTION	GUY H.	03-24-10

NOTES: UNLESS OTHERWISE SPECIFIED

1. ALL RESISTORS ARE IN OHMS, 0603.  
ALL CAPACITORS ARE IN MICROFARADS, 0603

ASSY	U1	BITS	MSPS	FULLY DIFFERENTIAL	J2 SHUNT
-A	LTC2393CLX-16	16	1	YES	-AIN
-B	LTC2392CLX-16	16	0.5	YES	-AIN
-C	LTC2391CLX-16	16	0.25	YES	-AIN

**CUSTOMER NOTICE**  
LINEAR TECHNOLOGY HAS MADE A BEST EFFORT TO DESIGN A CIRCUIT THAT MEETS CUSTOMER-SUPPLIED SPECIFICATIONS; HOWEVER, IT REMAINS THE CUSTOMER'S RESPONSIBILITY TO VERIFY PROPER AND RELIABLE OPERATION IN THE ACTUAL APPLICATION. COMPONENT SUBSTITUTION AND PRINTED CIRCUIT BOARD LAYOUT MAY SIGNIFICANTLY AFFECT CIRCUIT PERFORMANCE OR RELIABILITY. CONTACT LINEAR TECHNOLOGY APPLICATIONS ENGINEERING FOR ASSISTANCE.  
THIS CIRCUIT IS PROPRIETARY TO LINEAR TECHNOLOGY AND SUPPLIED FOR USE WITH LINEAR TECHNOLOGY PARTS.

APPROVALS	
PCB DES.	KT
APP ENG.	GUY H.

1630 McCarthy Blvd.  
Milpitas, CA 95035  
Phone: (408)432-1900 www.linear.com  
Fax: (408)434-6507  
LTC Confidential-For Customer Use Only

**LINEAR TECHNOLOGY**

TITLE: SCHEMATIC  
**LOW NOISE HIGH SPEED SAR ADC FAMILY**

SIZE B IC NO. LTC23XXCLX FAMILY REV. 1  
DEMO CIRCUIT 1500A

SCALE: NONE DATE: Wednesday, March 24, 2010 SHEET 1 OF 2

REVISION HISTORY				
ECO	REV	DESCRIPTION	APPROVED	DATE
	1	1ST PROTOTYPE	G. HOOVER	12-01-09

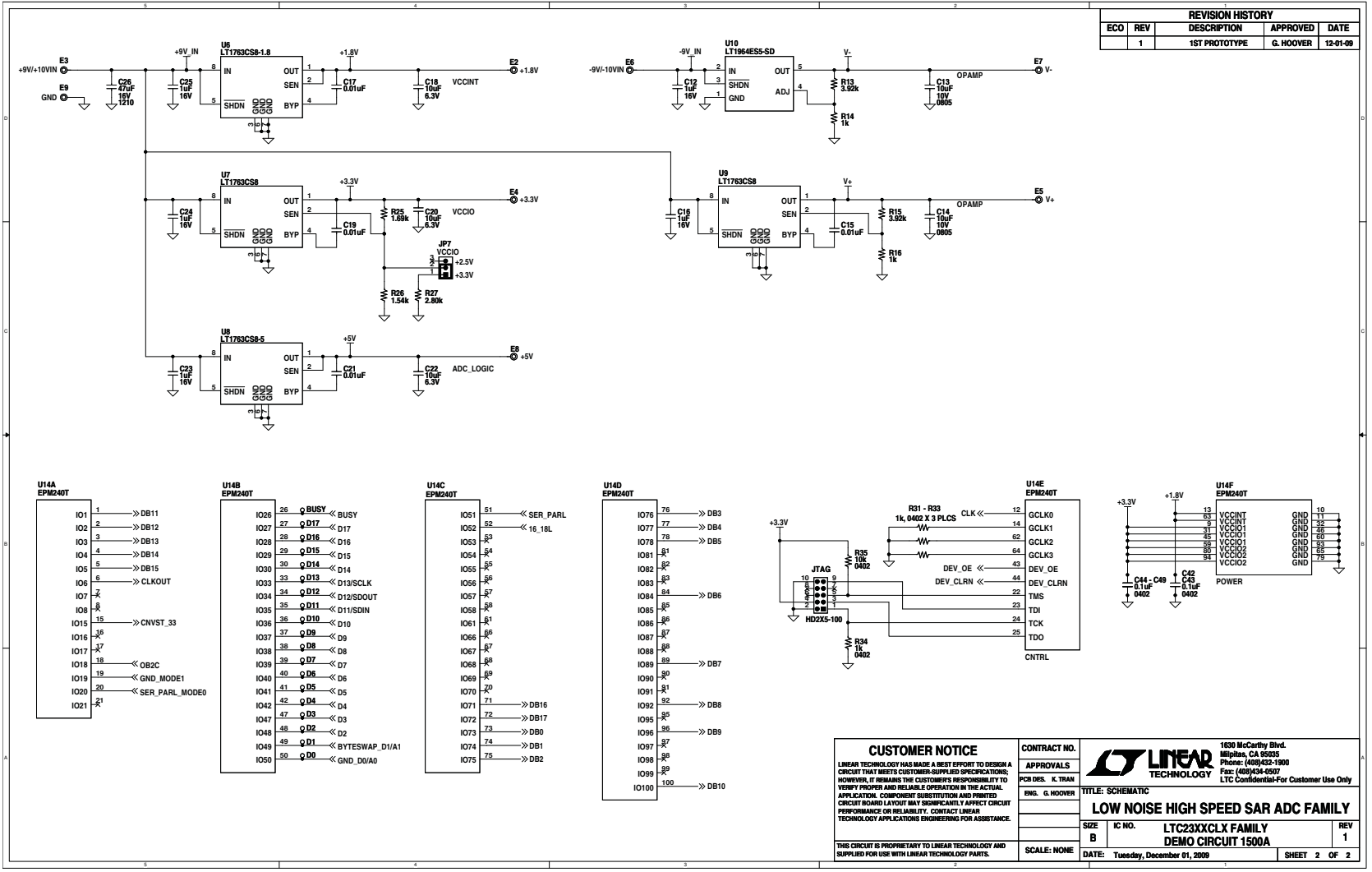

<b>CUSTOMER NOTICE</b> LINEAR TECHNOLOGY HAS MADE A BEST EFFORT TO DESIGN A CIRCUIT THAT MEETS CUSTOMER-SUPPLIED SPECIFICATIONS; HOWEVER, IT REMAINS THE CUSTOMER'S RESPONSIBILITY TO VERIFY PROPER AND RELIABLE OPERATION IN THE ACTUAL APPLICATION. COMPONENT SUBSTITUTION AND PRINTED CIRCUIT BOARD LAYOUT MAY SIGNIFICANTLY AFFECT CIRCUIT PERFORMANCE OR RELIABILITY. CONTACT LINEAR TECHNOLOGY APPLICATIONS ENGINEERING FOR ASSISTANCE.		CONTRACT NO. APPROVALS PCB DES. K. TRAN ENGR. G. HOOVER	<p>1630 McCarthy Blvd. Milpitas, CA 95035 Phone: (408)521-1900 Fax: (408)434-0507 LTC Confidential-For Customer Use Only</p>
<p><b>LOW NOISE HIGH SPEED SAR ADC FAMILY</b></p> <p>IC NO. <b>LTC23XXCLX FAMILY</b> REV <b>1</b></p> <p>DEMO CIRCUIT 1500A</p>		<p>DATE: Tuesday, December 01, 2009</p> <p>SHEET 2 OF 2</p>	

## ASSEMBLY DRAWINGS

REVISION HISTORY			
ECO	REV	DESCRIPTION	DATE
	1	1ST PROTOTYPE	12-01-09

**NOTES: UNLESS OTHERWISE SPECIFIED**

1. WORKMANSHIP SHALL BE IN ACCORDANCE WITH IPC-A-610.
2. INSTALL SHUNTS AS SHOWN.
3. DEPANELIZE BOARDS AFTER ASSEMBLY AND ROUTE-OUT THE BREAKOUT TABS ON FOUR SIDES OF THE BOARD EDGE.
4. ASSEMBLY PROCESS SHALL INCLUDE: REFLOW SOLDER TOP SIDE SMD.
5. INSTALL 4 STANDOFFS AT 4 CORNERS AS SHOWN BELOW:

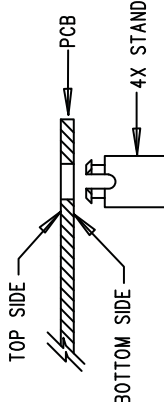

TOP SIDE  
BOTTOM SIDE  
4X STANDOFF, NYLON, SNAP ON.

**6.** MARK EACH LTC PART NUMBER AND ASSEMBLY TYPE WITH BLACK PERMANENT MARKER AS SHOWN IN TABLE BELOW:

ASSY	U1	Bits	MspS
A	LTC2393CLX-16	16	1
B	LTC2392CLX-16	16	0.5
C	LTC2391CLX-16	16	0.25

**7.** SW1 DEFAULT SETUP:  
SET LOW FOR: SER\_PARL; CSI; RDL.  
SET HIGH FOR: OB/2CL

**APPROVALS**

PCB DES.	KT
APP ENG.	GUY H.
SCALE = NONE	FILENAME: DC1500A-1.PCB
SHT 1 of 1	

**LINEAR TECHNOLOGY**  
1630 MCCARTHY BLVD  
MILPITAS, CA 95035  
PH: (408)432-9000  
LTC CONFIDENTIAL -  
FOR CUSTOMER USE ONLY

TITLE: TOP ASSEMBLY DRAWING  
LOW NOISE HIGH SPEED SAR ADC FAMILY

SIZE	IC NO.	LTC23XXCLX FAMILY	REV.
N/A		DEMO CIRCUIT 1500A	1

**APPROVALS**

PCB DES.	KT
APP ENG.	GUY H.
SCALE = NONE	FILENAME: DC1500A-1.PCB
SHT 1 of 1	

**LOW NOISE HIGH SPEED SAR ADC FAMILY**  
**DEMO CIRCUIT 1500A**

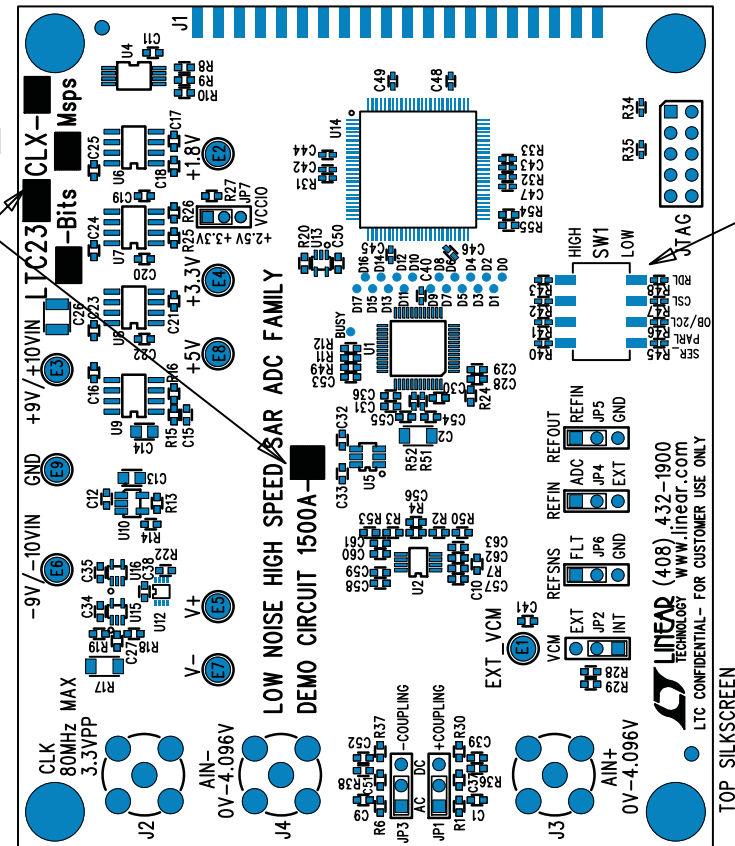

LINEAR (408) 432-1900  
www.linear.com  
LTC CONFIDENTIAL - FOR CUSTOMER USE ONLY

TOP SILKSCREEN  
LINEAR TECHNOLOGY  
DC1500A-LTC23XXCLX FAMILY  
DATE: 11-19-09

## PCB LAYOUT AND FILM

### Top Silkscreen

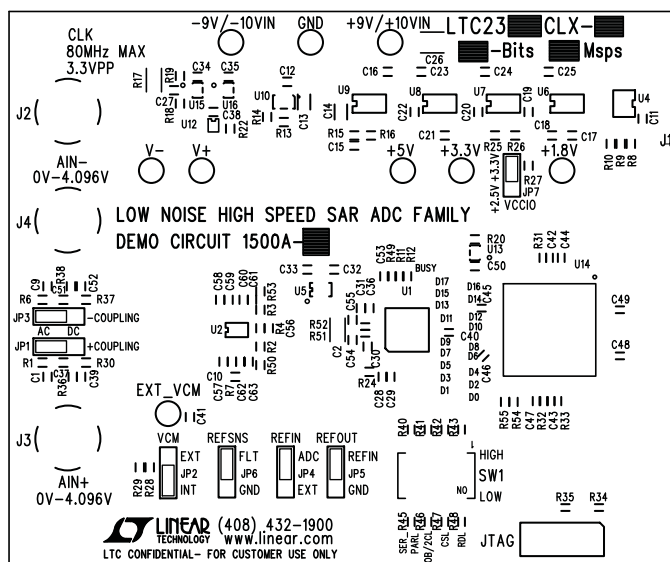

TOP SILKSCREEN  
 LINEAR TECHNOLOGY  
 DC1500A-LTC23XXCLX FAMILY  
 LOW NOISE HIGH SPEED SAR ADC FAMILY  
 DATE: 11-19-09

### Top Solder Paste

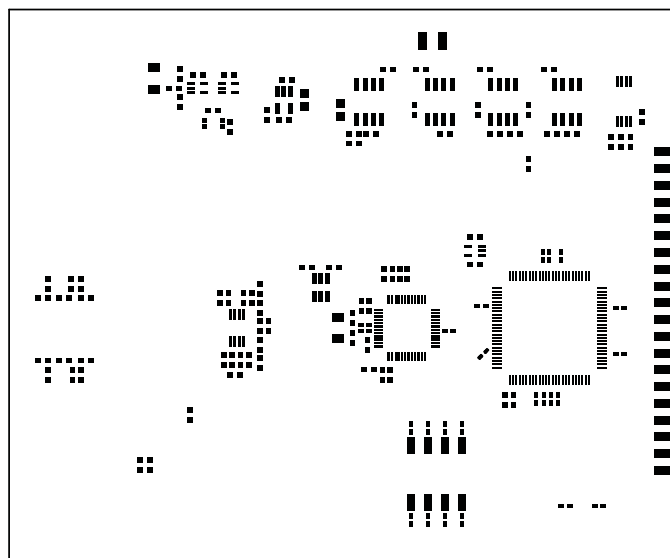

TOP SOLDER PASTE  
 LINEAR TECHNOLOGY  
 DC1500A-LTC23XXCLX FAMILY  
 LOW NOISE HIGH SPEED SAR ADC FAMILY  
 DATE: 11-02-09

## Top Solder Mask

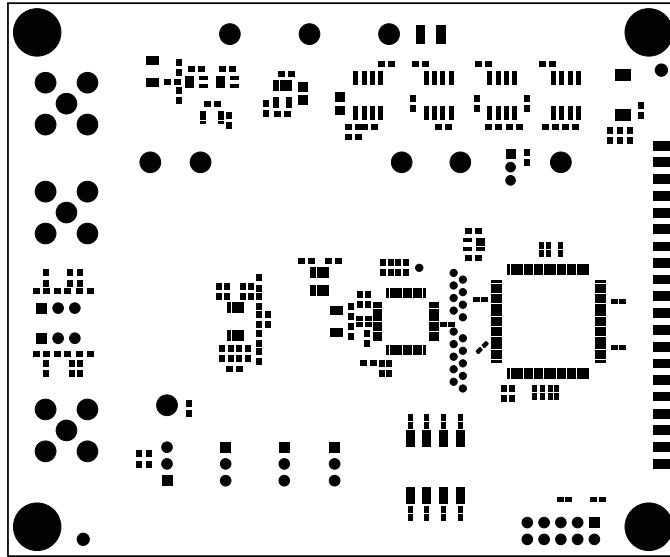

TOP SOLDER MASK  
LINEAR TECHNOLOGY  
DC1500A-LTC23XXCLX FAMILY

LOW NOISE HIGH SPEED SAR ADC FAMILY  
DATE: 11-02-09

## Top Layer

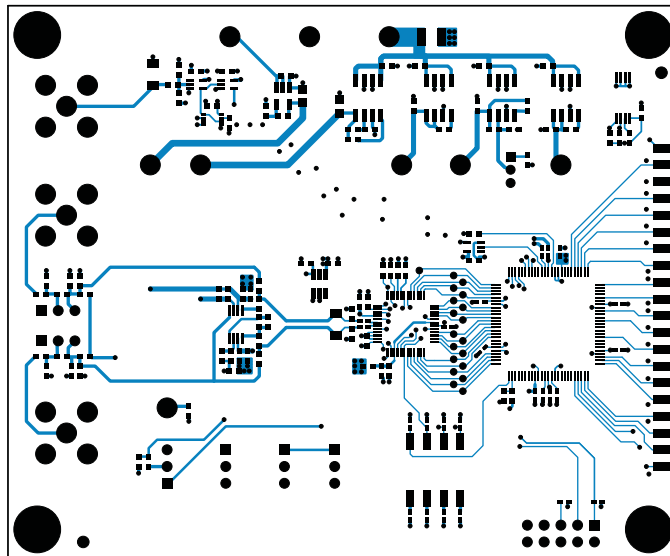

LAYER 1 - TOP LAYER  
LINEAR TECHNOLOGY  
DC1500A-LTC23XXCLX FAMILY

LOW NOISE HIGH SPEED SAR ADC FAMILY  
DATE: 11-02-09

PCB LAYOUT AND FILM

GND Plane 1

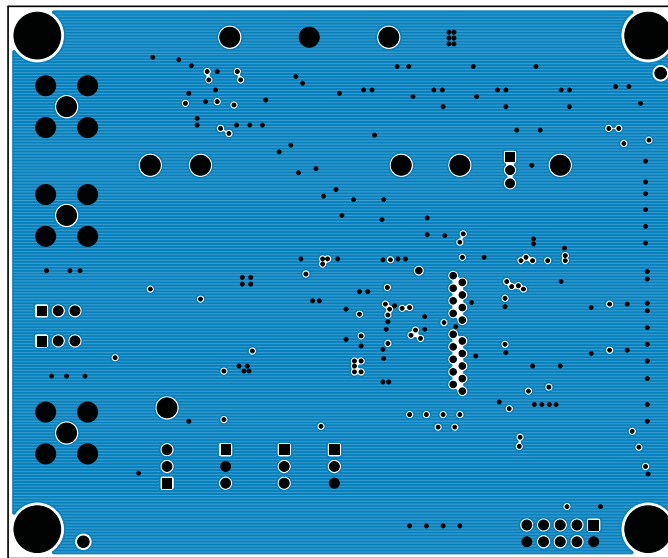

LAYER 2 - GND PLANE 1  
LINEAR TECHNOLOGY  
DC1500A-LTC23XXCLX FAMILY  
LOW NOISE HIGH SPEED SAR ADC FAMILY  
DATE: 11-02-09

GND Plane 2

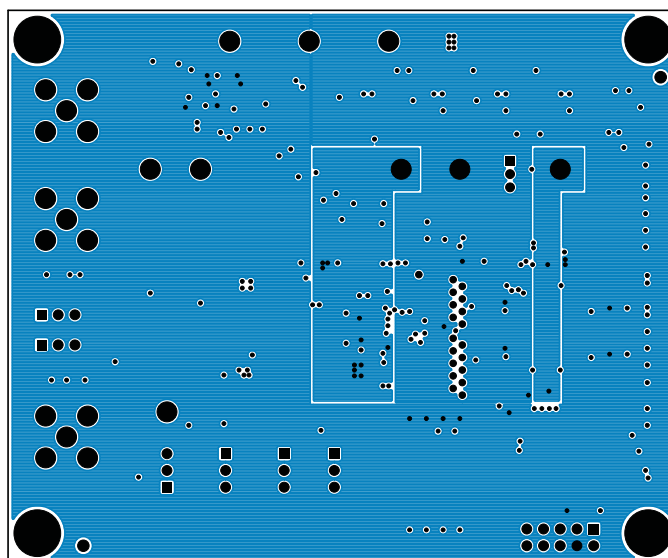

LAYER 3 - GND PLANE 2  
LINEAR TECHNOLOGY  
DC1500A-LTC23XXCLX FAMILY  
LOW NOISE HIGH SPEED SAR ADC FAMILY  
DATE: 11-02-09

## PCB LAYOUT AND FILM

Bottom Layer

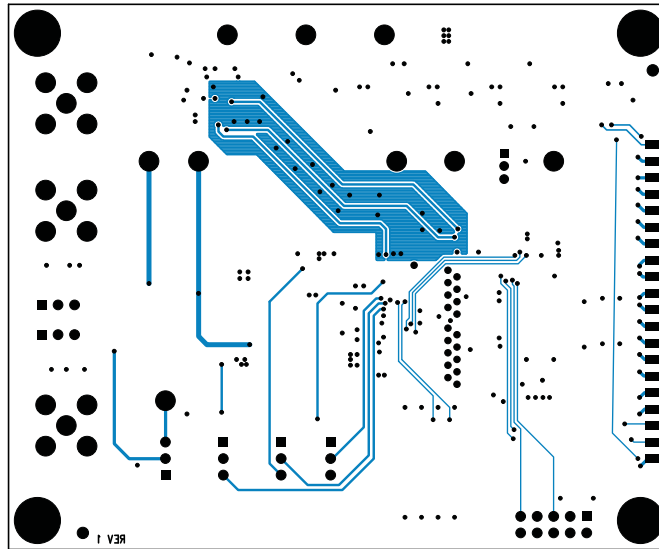

LAYER 4 - BOTTOM LAYER  
LINEAR TECHNOLOGY  
DC1500A-LTC23XXCLX FAMILY  
LOW NOISE HIGH SPEED SAR ADC FAMILY  
DATE: 11-02-09

Bottom Solder Mask

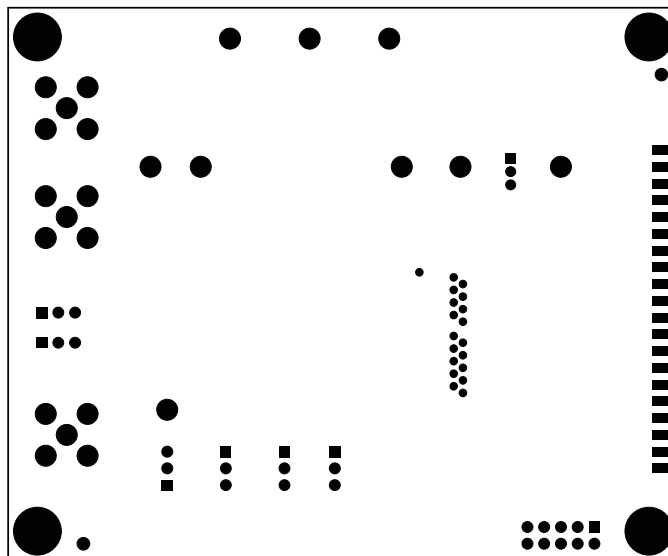

BOTTOM SOLDER MASK  
LINEAR TECHNOLOGY  
DC1500A-LTC23XXCLX FAMILY  
LOW NOISE HIGH SPEED SAR ADC FAMILY  
DATE: 11-02-09

FABRICATION DRAWINGS

REVISION HISTORY			
ECO REV	DESCRIPTION	APPR	DATE
1	1ST PROTOTYPE	G. HOOVER	11-02-09

SIZE	QTY	SYM	PLATED	TOL
0.07	2	+	NO	+/-0.003"
0.055	15	□	YES	+/-0.003"
0.01	214	◇	YES	+/-0.003"
0.035	31	⊠	YES	+/-0.003"
0.02	19	⊕	YES	+/-0.003"
0.188	4	⊕	YES	+/-0.003"
0.064	9	⊕	YES	+/-0.003"

**NOTES: UNLESS OTHERWISE SPECIFIED**

- FAB PER IPC-A-600.
- MATERIAL: -EPOXY FIBERGLASS, NEMA GRADE FR-4  
 -FINISHED THICKNESS TO BE 0.062" +/- .005"  
 -TOTAL OF 4 LAYERS WITH 2 OZ. CU ON THE OUTER LAYERS AND 1 OZ. CU ON THE INNER LAYERS.  
 -FLAMMABILITY RATING: 94 V-0 MINIMUM.  
 -CUT TO DIMENSIONS AND TOLERANCES SHOWN. 0.00" ARE PRIMARY DATUMS.
- DRILLING: -DRILL HOLES PER SCHEDULE. PLATE THROUGH HOLES WITH COPPER, 0.001" THICK MIN.  
 -ALL HOLE SIZES ARE SPECIFIED AFTER PLATING.  
 -HOLE LOCATION TOLERANCES ARE +/-0.003" IN RELATION TO CENTER
- FINISH: -SNOBC USING LPI BOTH SIDES, COLOR GREEN.  
 -GOLD IMMERSION BOTH SIDES.  
 (LEAD FREE SOLDER CAN BE USED FOR PROTOTYPE)  
 -FOR SILKSCREEN: BOTH SIDES USE WHITE NON-CONDUCTIVE INK.
- DO NOT ALTER ARTWORK e.g. TO ADD LOGO OR DATE CODE.  
 PAD SIZE CAN BE MODIFIED TO MEET END FINISH.
- PCBS ARE TO BE ROHS COMPLIANT.
- SCORING FOR PANELIZED PCB:

**LAYER STRUCTURE**

UNLESS OTHERWISE SPECIFIED DIMENSIONS ARE IN INCHES TOLERANCES ON ANGLE ±°	
0.24" = ±0.01"	
0.24" = ±0.005" TOL PER ASME Y14.5M-1994	
THIRD ANGLE PROJECTION	

APPROVALS	
NAME	DATE
PCB DES. K. TRAN	11-02-09
ENG. G. HOOVER	11-02-09

	<b>LINEAR TECHNOLOGY</b>
TITLE: FABRICATION DRAWING	
LOW NOISE HIGH SPEED SAR ADC FAMILY	
SIZE A	IC NO. LTC23XXCLX FAMILY REV. 1
FILENAME: DC1500A.PCB	SHT 1 of 1



# DEMO MANUAL DC1500A

---

## DEMONSTRATION BOARD IMPORTANT NOTICE

Linear Technology Corporation (LTC) provides the enclosed product(s) under the following **AS IS** conditions:

This demonstration board (DEMO BOARD) kit being sold or provided by Linear Technology is intended for use for **ENGINEERING DEVELOPMENT OR EVALUATION PURPOSES ONLY** and is not provided by LTC for commercial use. As such, the DEMO BOARD herein may not be complete in terms of required design-, marketing-, and/or manufacturing-related protective considerations, including but not limited to product safety measures typically found in finished commercial goods. As a prototype, this product does not fall within the scope of the European Union directive on electromagnetic compatibility and therefore may or may not meet the technical requirements of the directive, or other regulations.

If this evaluation kit does not meet the specifications recited in the DEMO BOARD manual the kit may be returned within 30 days from the date of delivery for a full refund. **THE FOREGOING WARRANTY IS THE EXCLUSIVE WARRANTY MADE BY THE SELLER TO BUYER AND IS IN LIEU OF ALL OTHER WARRANTIES, EXPRESSED, IMPLIED, OR STATUTORY, INCLUDING ANY WARRANTY OF MERCHANTABILITY OR FITNESS FOR ANY PARTICULAR PURPOSE. EXCEPT TO THE EXTENT OF THIS INDEMNITY, NEITHER PARTY SHALL BE LIABLE TO THE OTHER FOR ANY INDIRECT, SPECIAL, INCIDENTAL, OR CONSEQUENTIAL DAMAGES.**

The user assumes all responsibility and liability for proper and safe handling of the goods. Further, the user releases LTC from all claims arising from the handling or use of the goods. Due to the open construction of the product, it is the user's responsibility to take any and all appropriate precautions with regard to electrostatic discharge. Also be aware that the products herein may not be regulatory compliant or agency certified (FCC, UL, CE, etc.).

No License is granted under any patent right or other intellectual property whatsoever. **LTC assumes no liability for applications assistance, customer product design, software performance, or infringement of patents or any other intellectual property rights of any kind.**

LTC currently services a variety of customers for products around the world, and therefore this transaction **is not exclusive**.

**Please read the DEMO BOARD manual prior to handling the product.** Persons handling this product must have electronics training and observe good laboratory practice standards. **Common sense is encouraged.**

This notice contains important safety information about temperatures and voltages. For further safety concerns, please contact a LTC application engineer.

Mailing Address:

Linear Technology  
1630 McCarthy Blvd.  
Milpitas, CA 95035

Copyright © 2004, Linear Technology Corporation