

Chipsmall Limited consists of a professional team with an average of over 10 year of expertise in the distribution of electronic components. Based in Hongkong, we have already established firm and mutual-benefit business relationships with customers from,Europe,America and south Asia,supplying obsolete and hard-to-find components to meet their specific needs.

With the principle of “Quality Parts,Customers Priority,Honest Operation,and Considerate Service”,our business mainly focus on the distribution of electronic components. Line cards we deal with include Microchip,ALPS,ROHM,Xilinx,Pulse,ON,Everlight and Freescale. Main products comprise IC,Modules,Potentiometer,IC Socket,Relay,Connector.Our parts cover such applications as commercial,industrial, and automotives areas.

We are looking forward to setting up business relationship with you and hope to provide you with the best service and solution. Let us make a better world for our industry!



Contact us

Tel: +86-755-8981 8866 Fax: +86-755-8427 6832

Email & Skype: info@chipsmall.com Web: www.chipsmall.com

Address: A1208, Overseas Decoration Building, #122 Zhenhua RD., Futian, Shenzhen, China

LTC4070EDDB: Simple Low-Iq Battery Charger/Protector With NTC Thermistor Input

DESCRIPTION

Demonstration Circuit DC1584A is a Simple Low-Iq Battery Charger/Protector With NTC Thermistor featuring the LTC[®]4070EDDB.

PERFORMANCE SUMMARY Specifications are at $T_R = 25^\circ\text{C}$

SYMBOL	PARAMETER	CONDITIONS	MIN	TYP	MAX	UNITS
VBUS	Input voltage	$R_{LIMIT} = 169\Omega$	10	12	16	V
V(BAT)	Battery Float Voltage	'VFLOAT' jumper on 4.1V, Constant Voltage Mode. $T_{NTC} = 25^\circ\text{C}$	4.059		4.141	V
I(BAT)	Battery Charge Current	Constant Current Mode, $V_{in} = 12\text{V}$, $V_{CC} = 3.8\text{V}$		49.7		mA

QUICK START PROCEDURE

Refer to Figure 1 for the proper measurement equipment setup and jumper settings and follow the procedure below.

NOTE. When measuring the input or output voltage ripple, care must be taken to avoid a long ground lead on the oscilloscope probe. Measure the input or output voltage ripple by touching the probe tip directly across the VBUS or Vcc and GND terminals. See Figure 2 for proper scope probe technique.

1. Set PS1 = 12V, PS2 = 3.6V, "VFLOAT" (JP2) to 4.1V. Observe I(VBUS) (AM1). The voltage on the battery is below the LTC4070EDDB's float voltage. So all the current is flowing into the battery, and that current is $(12\text{V} - 3.6\text{V}) / 169(R1) = 49.7\text{mA}$.
2. If "LBO" LED lit, decrease PS2 until off. Observe BAT (VM2). The LBO output goes high when the battery voltage is below 3.2V, but it has 200-300mV of hysteresis. So it may not go low until 3.5V, with Vcc \uparrow .
3. Increase PS2 until LBO is lit. Observe BAT (VM2).
4. Increase PS2 until HBO lit. Observe BAT (VM2). The HBO LED will light when the battery voltage is within ~50mV of the float voltage.
5. Disconnect PS2, AM2, and 3.6 Ω resistor. Observe BAT (VM2). The only limit to the Vcc voltage now is the LTC4070, so the voltage will rise to the float voltage.
6. Reset the Jumpers to their default position.

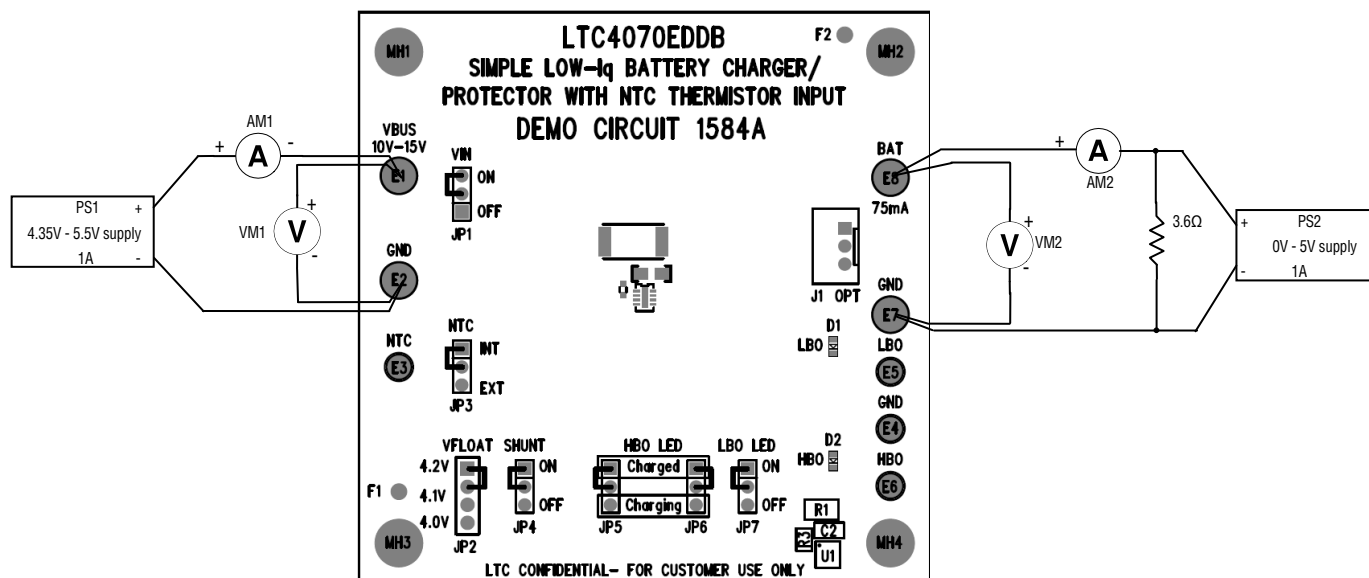

Note: All connections from equipment should be Kelvin connected directly to the board pins which they are connected on this diagram and any input or output leads should be twisted pair.

Figure 1. Proper Measurement Equipment Setup for DC1584A

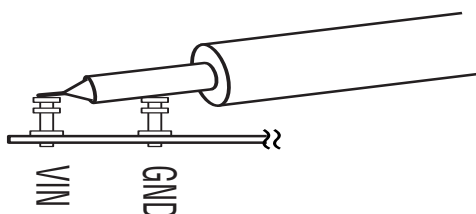
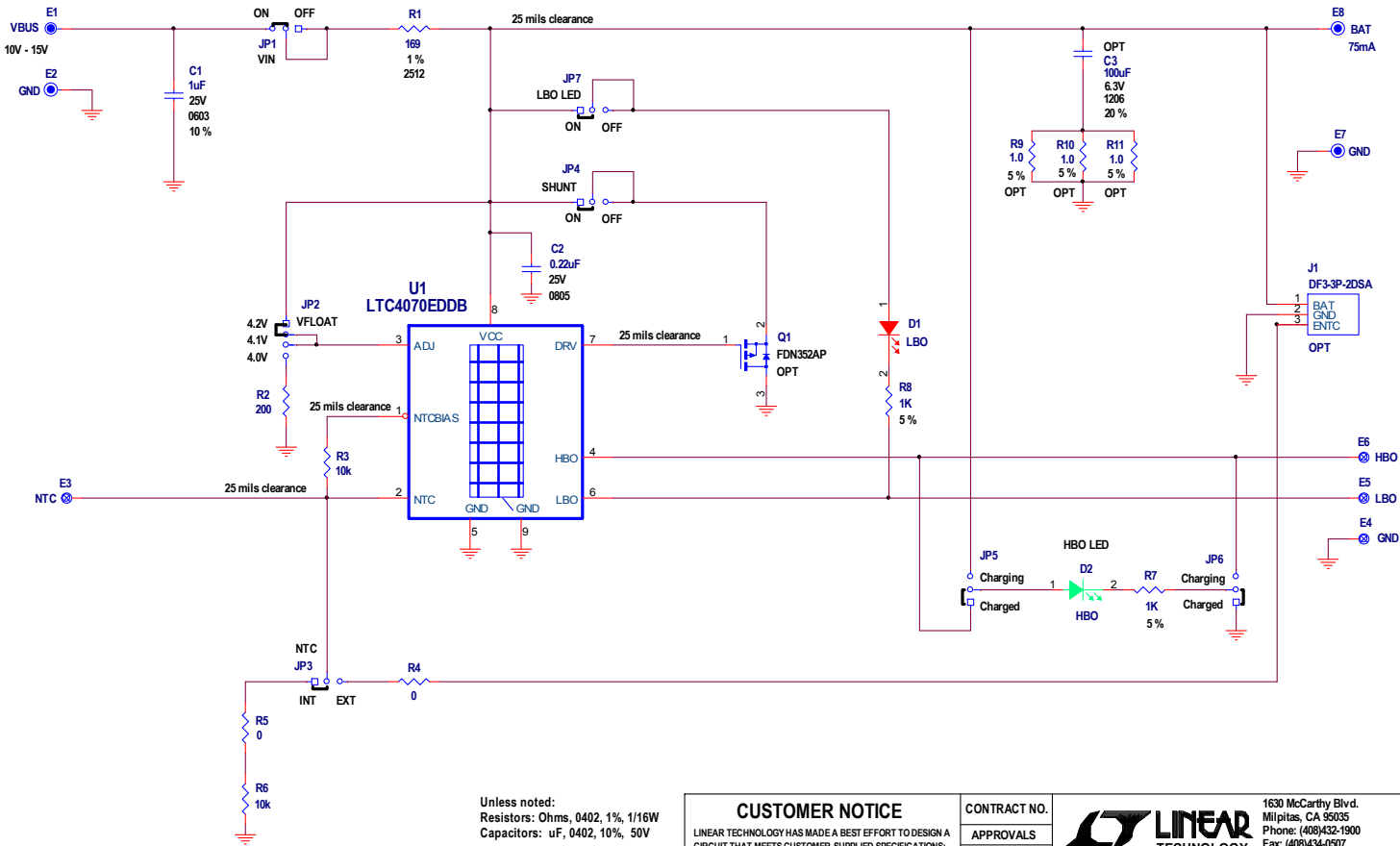

Figure 2. Measuring Input or Output Ripple

REVISION HISTORY				
ECO	REV	DESCRIPTION	APPROVED	DATE
	A	PRODUCTION RELEASE	NJC	10/15/09

Figure 3. Schematic



Unless noted:
Resistors: Ohms, 0402, 1%, 1/16W
Capacitors: µF, 0402, 10%, 50V

CUSTOMER NOTICE		CONTRACT NO.		 1630 McCarthy Blvd. Milpitas, CA 95035 Phone: (408)432-1900 Fax: (408)434-0507 LTC Confidential-For Customer Use Only	
LINEAR TECHNOLOGY HAS MADE A BEST EFFORT TO DESIGN A CIRCUIT THAT MEETS CUSTOMER-SUPPLIED SPECIFICATIONS. HOWEVER, IT REMAINS THE CUSTOMER'S RESPONSIBILITY TO VERIFY PROPER AND RELIABLE OPERATION IN THE ACTUAL APPLICATION. COMPONENT SUBSTITUTION AND PRINTED CIRCUIT BOARD LAYOUT MAY SIGNIFICANTLY AFFECT CIRCUIT PERFORMANCE OR RELIABILITY. CONTACT LINEAR TECHNOLOGY APPLICATIONS ENGINEERING FOR ASSISTANCE.		APPROVALS DRAWN: G. Barbehenn CHECKED: APPROVED: ENGINEER: G. Barbehenn DESIGNER:		TITLE: LTC4070EDDB: SIMPLE LOW - Iq BATTERY CHARGER / PROTECTOR WITH NTC THERMISTOR INPUT	
THIS CIRCUIT IS PROPRIETARY TO LINEAR TECHNOLOGY AND SUPPLIED FOR USE WITH LINEAR TECHNOLOGY PARTS.		SIZE X		DWG NO. DC1584A	
		DATE: Wednesday, November 04, 2009		REV A	
				SHEET 1 OF 1	

Qty	Reference	Part Description	Manufacture / Part #
REQUIRED CIRCUIT COMPONENTS:			
1	C1	CAP, CHIP, X5R, 1 μ F, \pm 20%, 25V, 0603	AVX, 06033D105MAT2A
2	C2	CAP, CHIP, X7R, 0.22 μ F, \pm 10%, 25V, 0805	VISHAY, VJ0805Y224KXXA
3	R1	RES, CHIP, 169 Ω , \pm 1%, 1W, 2512	VISHAY, CRCW2512169RFKED
4	R2	RES, CHIP, 200 Ω , \pm 1%, 1/16W, 0402	VISHAY, CRCW0402200RFKED
5	R3, R6	RES, CHIP, 10k Ω , \pm 1%, 1/16W, 0402	VISHAY, CRCW040210K0FKED
6	R4, R5	RES, CHIP, 0 Ω jumper, 1/16W, 0402	VISHAY, CRCW04020000Z0ED
7	R7, R8	RES, CHIP, 1k Ω , \pm 5%, 1/16W, 0402	VISHAY, CRCW04021K00JNED
8	U1	IC, SMT, SIMPLE LOW-Iq BATTERY CHARGER / PROTECTOR WITH NTC THERMISTOR INPUT	LINEAR TECH., LTC4070EDDB
ADDITIONAL DEMO BOARD CIRCUIT COMPONENTS:			
1	C3-OPT	CAP, CHIP, X5R, 100 μ F, \pm 20%, 6.3V, 1206	MURATA, GRM31CR60J107ME39L
2	D1	DIODE, LED, RED, 0603	Panasonic, LNJ208R8ARA
3	D2	DIODE, LED, GREEN, 0603	LITE-ON, LTST-C190KGKT
4	Q1-OPT	MOSFET, P-channel, -30V, -1.1A, 0.30 Ω , SSOT-23	FAIRCHILD, FDN352AP
5	R9-OPT, R10-OPT, R11-OPT	RES, CHIP, 1 Ω , \pm 5%, 1/16W, 0402	VISHAY, CRCW04021R00JNED
HARDWARE FOR DEMO BOARD ONLY:			
1	E1-2, E7-8	TURRET, 0.09 DIA	MILL-MAX, 2501-2-00-80-00-00-07-0
2	E3-6	TURRET, 0.061 DIA	MILL-MAX, 2308-2-00-80-00-00-07-0
3	J1-OPT	CONN, 3 Pin Polarized	HIROSE, DF3-3P-2DSA
4	JP1, JP3-7	3 Pin Jumper, 2mm	SAMTEC, TMM-103-02-L-S
5	JP2	4 Pin Jumper, 2mm	SAMTEC, TMM-104-02-L-S
6	JP1-7	SHUNT, 2mm	SAMTEC, 2SN-KB-G
7		STAND-OFF, NYLON, 0.375"	KEYSTONE, 8832

Figure 4. Bill of Materials