



Chipsmall Limited consists of a professional team with an average of over 10 year of expertise in the distribution of electronic components. Based in Hongkong, we have already established firm and mutual-benefit business relationships with customers from,Europe,America and south Asia,supplying obsolete and hard-to-find components to meet their specific needs.

With the principle of "Quality Parts,Customers Priority,Honest Operation,and Considerate Service",our business mainly focus on the distribution of electronic components. Line cards we deal with include Microchip,ALPS,ROHM,Xilinx,Pulse,ON,Everlight and Freescale. Main products comprise IC,Modules,Potentiometer,IC Socket,Relay,Connector.Our parts cover such applications as commercial,industrial, and automotives areas.

We are looking forward to setting up business relationship with you and hope to provide you with the best service and solution. Let us make a better world for our industry!



Contact us

Tel: +86-755-8981 8866 Fax: +86-755-8427 6832

Email & Skype: info@chipsmall.com Web: www.chipsmall.com

Address: A1208, Overseas Decoration Building, #122 Zhenhua RD., Futian, Shenzhen, China



LTC6417

1.6GHz Low Noise Differential 16-Bit ADC Buffer

DESCRIPTION

Demonstration circuit 1660B features the LTC®6417 differential 16-bit ADC buffer. The demo board incorporates a variety of passive components to allow for direct connection to a two-port network analyzer or other single-ended 50Ω test system.

The demo board is easily configured to control common-mode voltage V_{CM} , clamp voltage CLHI, power adjust

PWRADJ, and SHUTDOWN pins. Other simple PCB modifications can accommodate differential input/output signals.

Design files for this circuit board are available at <http://www.linear.com/demo>

LT, LT, LTC, LTM, Linear Technology and the Linear Logo are registered trademarks of Linear Technology Corporation. All other trademarks are the property of their respective owners.

QUICK START PROCEDURE

DC1660B is easy to set up to evaluate the performance of the LTC6417. Refer to Figure 1 for proper measurement equipment setup and follow the procedure below:

1. Connect SMA cables to IN⁺ and OUT⁺ ports.
2. Apply 5.0V between V⁺ and GND turrets.

Tie PWRADJ (TURRET E4) to V⁺. Limit supply current to approximately 150mA.

3. V_{CM} , CLHI and SHDN turrets may be left floating.

This procedure contains a critical sequence. The user must apply supply voltage before applying signal power to the inputs or forcing a voltage to any other turrets. The user must also remove the signal from the input ports and voltages on any other turret before turning down the supply voltage. This proper sequence will prevent excessive current through the ESD diodes from any pin

to the positive supply V⁺. Table 1 shows the function of each SMA connector on the board. Only J1, J3 and J5 are used in the default configuration. J2 and J4 provide flexibility for differential input/output signals.

Table 1. DC1660B SMA Connectors

CONNECTOR	FUNCTION
J1 (IN ⁺)	Differential input connected to input balun for single-ended operation. Drive from a 50Ω signal source. No external termination needed.
J2 (IN ⁻)	Differential Input. Not connected by default. Remove capacitor C12 to drive the input balun differentially.
J3 (OUT ⁺)	Differential output connected to balun for single-ended operation. Connect to a 50Ω network/spectrum analyzer input.
J4 (OUT ⁻)	Differential Output. Not connected by default. Remove capacitor C11 to drive the input balun differentially.
J5 (OR)	Overrange Output. Connect to oscilloscope for monitoring the output signal.

QUICK START PROCEDURE

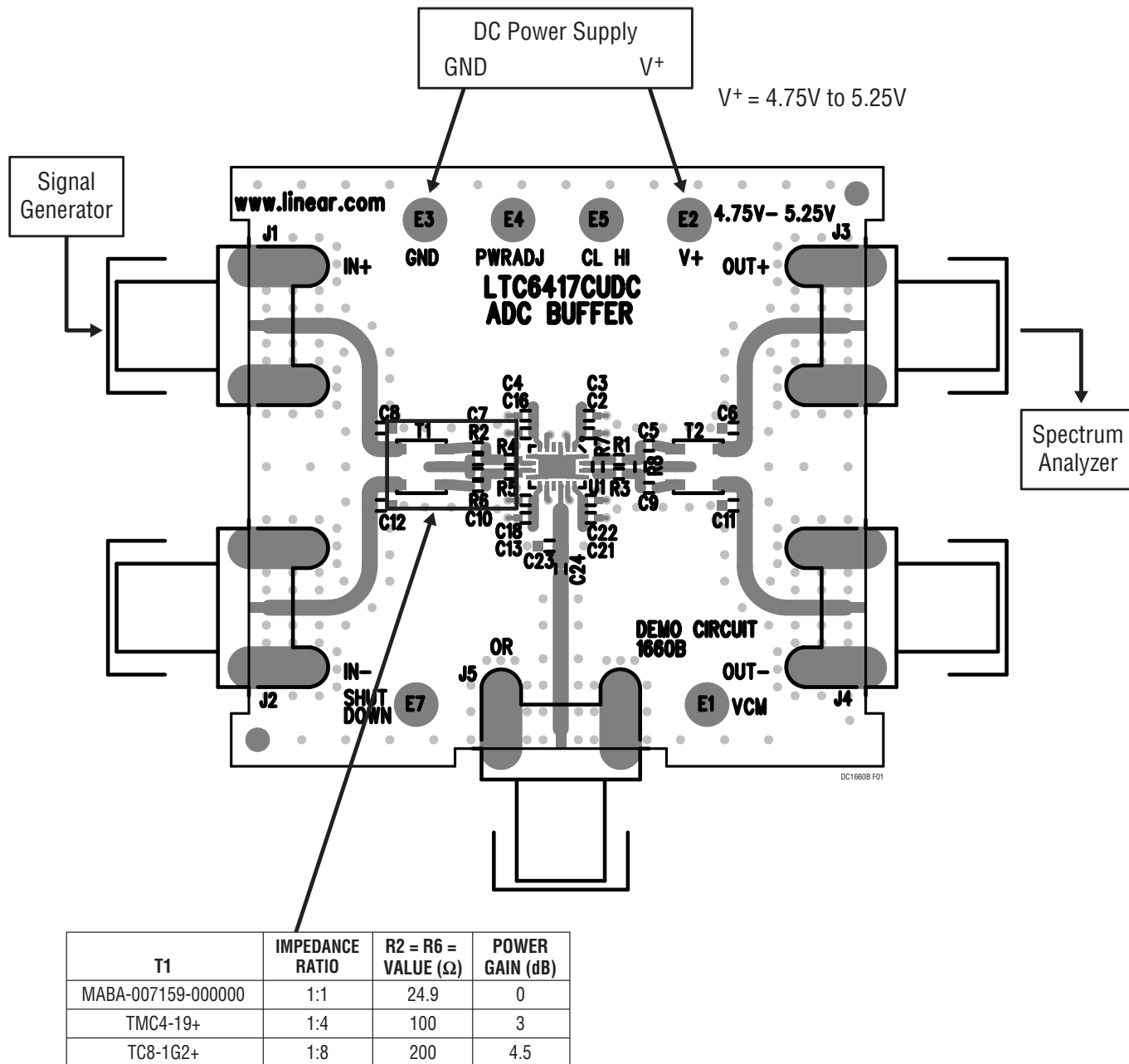

Figure 1. Proper Measurement Equipment Setup

APPLICATIONS INFORMATION

Input

Demo board DC1660B's single-ended input is AC-coupled at port J1. The balun transformer T1 has a 1:4 impedance ratio and it is matched to 50Ω at its input, when resistors R2 and R6 are equal to 100Ω.

To drive the inputs differentially, remove capacitor C12.

To DC-couple the inputs, replace DC blocking capacitors C7 and C10 with 0Ω resistors.

Output

The board's output transformer T2 has a 1:1 impedance ratio. T2 converts the LTC6417's differential output signals to a single-ended output.

To match T2 to 50Ω, change output series resistors R1 and R3 to 23.7Ω each.

For differential outputs, remove capacitor C11.

To DC-couple the outputs, replace DC blocking capacitors C5 and C9 with a 0Ω resistor.

Additional Information

The demo board DC1660B is ready to use out of the box. The demo board is shipped with the default configuration as single ended input and output. However, it has features that you can access by adding, removing or changing components on the board. Refer to LTC6417 data sheet for more information.

Output Common Mode Adjustment

Turret E1, labeled V_{CM} , controls the output common mode voltage of the LTC6417.

This function can be used to set the DC output voltage for optimum system performance.

In the default configuration, C5 and C9 block the DC output voltages. Replace these capacitors with 0Ω jumpers, and the transmission-line type transformer T2 will couple the DC voltages to the output port J3. If turret E1 is left floating, the LTC6417 will self-bias the V_{CM} pin to 1.25V on a 5.0V supply. The V_{CM} pin has a voltage range from 0.85V to 1.65V.

CLHI

Turret E5, labeled CLHI, controls the high side clamping voltage of the LTC6417. If turret E5 is left floating, the LTC6417 will self-bias the CLHI pin to 2.5V on a 5.0V supply. The internal low side clamping voltage and CLHI is symmetric with respect to V_{CM} . When CLHI = 2.5V, and $V_{CM} = 1.25V$, internal low side clamp will be 0V. Either output will be limited by these clamp voltages. See the LTC6417 data sheet for more information.

PWRADJ

Turret E4, labeled PWRADJ, scales the supply current of the LTC6417. If turret E4 is left floating, the LTC6417 will self-bias the PWRADJ pin to 1.6V on a 5.0V supply with a supply current of approximately 115mA.

Shutdown

Turret E7, labeled SHUTDOWN, puts the LTC6417 into sleep mode when pulled high, significantly reducing supply current (~25mA). If turret E7 is left floating, the LTC6417 will pull the SHUTDOWN pin to GND potential and remain enabled.

Schematic Note

The schematic included at the end of this Quick Start Guide includes approximate power gains at various points along DC1660B's signal chain. The power gains (PG1 – PG4) assume single-ended 50Ω test system and the LTC6417 is operating in a small-signal region. If the output load is a high-impedance load, the power gains PG3 – PG4 will vary from the schematic.

DEMO MANUAL DC1660B

PARTS LIST

ITEM	QTY	REFERENCE	PART DESCRIPTION	MANUFACTURER/PART NUMBER
1	15	C1, C3, C4, C5, C7, C9, C10, C13-C15, C17, C19-C21, C24	CAP., X5R, 0.1 μ F, 16V, 10% 0402	AVX, 0402YD104KAT2A
2	4	C2, C16, C18, C22	CAP., X7R, 680pF, 50V, 10% 0402	AVX, 04025C681KAT2A
3	2	C11, C12	CAP., X7R, 0.1 μ F, 25V, 20% 0603	AVX, 06033C104MAT2A
4	0	C6, C8, C23	CAP., OPT 0603	(OPT)
5	6	E1, E2, E3, E4, E5, E7	TESTPOINT TURRET, .061" PBF	MILL-MAX, 2308-2-00-80-00-00-07-0
6	5	J1, J2, J3, J4, J5	CON., SMA 50 Ω EDGE-LAUNCH	E.F JOHNSON, 142-0701-851/132357
7	2	R2, R6	RES., CHIP, 100 Ω , 1/16W, 1% 0402	VISHAY CRCW0402100RFKED
8	4	R1, R3, R4, R5	RES., CHIP, 0 Ω , 1/16W, 1% 0402	VISHAY, CRCW04020000Z0ED
9	0	R7, R8	RES., CHIP OPT 0402	(OPT)
10	1	T1	TRANSFORMER, TCM4-19+ SM-22	MINI-CIRCUITS TCM4-19+
11	1	T2	TRANSFORMER, ETC1-1-13, SM-22	M/A-COM, MABA-007159-000000 (PBF)
12	1	U1	I.C. LTC6417CUDC UDC 20 PIN (3 \times 4)	LINEAR, LTC6417CUDC#PBF
13	1		FAB, PRINTED CIRCUIT BOARD	DEMO CIRCUIT 1660B
14	2		STENCILS TOP AND BOTTOM	STENCIL DC1660B

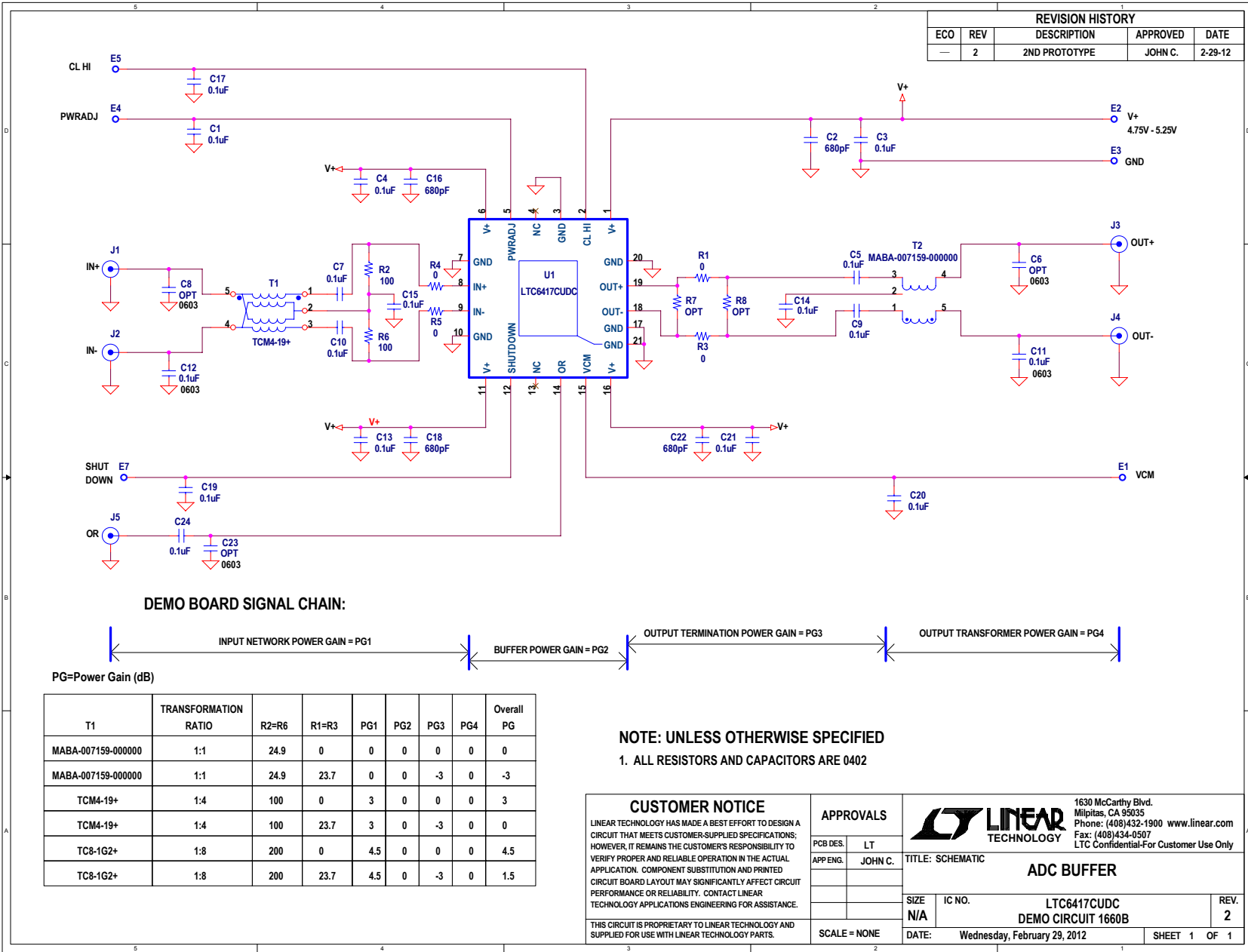

DEMO MANUAL DC1660B

DEMONSTRATION BOARD IMPORTANT NOTICE

Linear Technology Corporation (LTC) provides the enclosed product(s) under the following **AS IS** conditions:

This demonstration board (DEMO BOARD) kit being sold or provided by Linear Technology is intended for use for **ENGINEERING DEVELOPMENT OR EVALUATION PURPOSES ONLY** and is not provided by LTC for commercial use. As such, the DEMO BOARD herein may not be complete in terms of required design-, marketing-, and/or manufacturing-related protective considerations, including but not limited to product safety measures typically found in finished commercial goods. As a prototype, this product does not fall within the scope of the European Union directive on electromagnetic compatibility and therefore may or may not meet the technical requirements of the directive, or other regulations.

If this evaluation kit does not meet the specifications recited in the DEMO BOARD manual the kit may be returned within 30 days from the date of delivery for a full refund. **THE FOREGOING WARRANTY IS THE EXCLUSIVE WARRANTY MADE BY THE SELLER TO BUYER AND IS IN LIEU OF ALL OTHER WARRANTIES, EXPRESSED, IMPLIED, OR STATUTORY, INCLUDING ANY WARRANTY OF MERCHANTABILITY OR FITNESS FOR ANY PARTICULAR PURPOSE. EXCEPT TO THE EXTENT OF THIS INDEMNITY, NEITHER PARTY SHALL BE LIABLE TO THE OTHER FOR ANY INDIRECT, SPECIAL, INCIDENTAL, OR CONSEQUENTIAL DAMAGES.**

The user assumes all responsibility and liability for proper and safe handling of the goods. Further, the user releases LTC from all claims arising from the handling or use of the goods. Due to the open construction of the product, it is the user's responsibility to take any and all appropriate precautions with regard to electrostatic discharge. Also be aware that the products herein may not be regulatory compliant or agency certified (FCC, UL, CE, etc.).

No License is granted under any patent right or other intellectual property whatsoever. **LTC assumes no liability for applications assistance, customer product design, software performance, or infringement of patents or any other intellectual property rights of any kind.**

LTC currently services a variety of customers for products around the world, and therefore this transaction **is not exclusive**.

Please read the DEMO BOARD manual prior to handling the product. Persons handling this product must have electronics training and observe good laboratory practice standards. **Common sense is encouraged.**

This notice contains important safety information about temperatures and voltages. For further safety concerns, please contact a LTC application engineer.

Mailing Address:

Linear Technology
1630 McCarthy Blvd.
Milpitas, CA 95035

Copyright © 2004, Linear Technology Corporation