



Chipsmall Limited consists of a professional team with an average of over 10 year of expertise in the distribution of electronic components. Based in Hongkong, we have already established firm and mutual-benefit business relationships with customers from,Europe,America and south Asia,supplying obsolete and hard-to-find components to meet their specific needs.

With the principle of "Quality Parts,Customers Priority,Honest Operation,and Considerate Service",our business mainly focus on the distribution of electronic components. Line cards we deal with include Microchip,ALPS,ROHM,Xilinx,Pulse,ON,Everlight and Freescale. Main products comprise IC,Modules,Potentiometer,IC Socket,Relay,Connector.Our parts cover such applications as commercial,industrial, and automotives areas.

We are looking forward to setting up business relationship with you and hope to provide you with the best service and solution. Let us make a better world for our industry!



Contact us

Tel: +86-755-8981 8866 Fax: +86-755-8427 6832

Email & Skype: info@chipsmall.com Web: www.chipsmall.com

Address: A1208, Overseas Decoration Building, #122 Zhenhua RD., Futian, Shenzhen, China



LT3791

Four-Switch Buck-Boost LED Driver Controller

DESCRIPTION

Demonstration circuit DC1666A is a synchronous four-switch buck-boost LED driver controller. It accepts an input voltage from 4.7V to 60V, and drives up to 25V of LEDs at 2A. DC1666A features both PWM and analog dimming of the LED string. It has an OPENLED flag that indicates when the LED string has been removed and it has a SHORTLED flag that indicates that the output has been shorted to GND. In both cases, the IC remains in control and well protected.

DC1666A features very high efficiency at 300kHz switching frequency and continuous conduction mode (C_{CM}). The synchronous four-switch topology both steps up and steps down voltage while regulating up to 50W of constant LED output current at efficiencies up to 98%. The circuit can be altered for applications requiring over 100W of LEDs. An optional SYNC terminal is provided for synchronizing to an external clock and CLKOUT terminal provides a source to sync another converter to the internal clock of the LT[®]3791.

Three sense resistors provide constant output current control and monitoring, peak switch current control, and DC input current limit and monitoring. The I_{SMON} and I_{VINMON} outputs tell the user how much current is flowing through the output and input sense resistors.

Small ceramic input and output capacitors are used to save space and cost. The open LED overvoltage protection uses the IC's constant voltage regulation loop to limit the output to approximately 28.3V if the LED string is opened.

For low input voltage operation, the CTRL pin voltage is reduced as the input voltage drops below 6.5V, reducing

LED brightness and restraining the peak switch currents in order to limit inductor and switch size. UVLO turns the LEDs off when V_{IN} drops below 4.7V. When input rises above 57.6V, overvoltage lockout turns the switches off to protect them and they turn back on when V_{IN} drops below 56.2V.

DC1666A PWM dimming is simple. The PWM dimming MOSFET turns the LED string on and off with an input to the PWM dimming terminal. For the highest PWM dimming ratio, it is recommended to use 100Hz as a PWM dimming frequency. Information regarding PWM dimming ratios and performance can be found in the Applications Information section of the LT3791 data sheet. Analog dimming is also simple with a simple voltage source on the CTRL terminal.

Modifications can be made to DC1666A in order to convert the board to higher or lower power or from an LED driver to a constant voltage regulator or battery charger. Please consult the factory or the LT3791 data sheet for details.

The LT3791 data sheet gives a complete description of the part, operation and applications information. The data sheet must be read in conjunction with this demo manual for demonstration circuit DC1666A. The LT3791 is assembled in a 38-lead plastic TSSOP package with a thermally enhanced ground pad. Proper board layout is essential for maximum thermal performance. See the Layout Considerations section in the data sheet.

Design files for this circuit board are available at <http://www.linear.com/demo>

LT, LT, LTC, LTM, Linear Technology and the Linear logo are registered trademarks of Linear Technology Corporation. All other trademarks are the property of their respective owners.

DEMO MANUAL DC1666A

PERFORMANCE SUMMARY (T_A = 25°C)

PARAMETER	CONDITION	VALUE (TYPICAL)
Input Voltage PV _{IN} Range*	Operating	4.7V to 60V*
Switching Frequency	R12 = 86.6k	300kHz
I _{LED}	CTRL = Float, 7V < PV _{IN} < 57.6V	2.0A
V _{LED} Range	R7 = 1M, R9 = 44.2k	9.5V < V _{LED} < 25.5V
Open LED Voltage	R7 = 1M, R9 = 44.2k	28.3V
Typical Efficiency Boost Region	PVIN = 20V, V _{LED} = 25V, I _{LED} = 2A	97.5%
Typical Efficiency Buck-Boost Region	PVIN = 24V, V _{LED} = 25V, I _{LED} = 2A	96.8%
Typical Efficiency Buck Region	PVIN = 30V, V _{LED} =25V, I _{LED} = 2A	97.3%
Undervoltage Lockout (Falling Turn-Off)	R13 = 332k and R6 = 115k	4.7V
Undervoltage Lockout (Rising Turn-On)	R13 = 332k and R6 = 115k	5.7V
Overvoltage Lockout (Rising Turn-Off)	R11 = 54.9k, R19 = 1M	57.6V
Overvoltage Lockout (Falling Turn-On)	R11 = 54.9k, R19 = 1M	56.2V
Peak Switch Current Limit Boost Region	RS = 0.004Ω	11A
Valley Switch Current Limit Buck Region	RS = 0.004Ω	10A

* The guaranteed input voltage range of the LT3791 is 4.7V to 60V. Overvoltage lockout is set externally at 57.6V on this demo circuit to protect the 60V MOSFETs M1 and M2. Overvoltage lockout is adjustable.

QUICK START PROCEDURE

Demonstration circuit DC1666A is easy to set up to evaluate the performance of the LT3791. Follow the procedure below:

NOTE: PWM must be pulled high to run. If PWM is not used, connect PWM to a 5V source or to INTV_{CC} on the PCB using 0Ω resistor R22.

1. Connect a string of LEDs that will run with forward voltage less than 25.5V, but greater than 9.5V, to the LED⁺ and LED⁻ terminals on the PCB as shown in Figure 1.
2. Connect the EN/UVLO terminal to GND.
3. With power off, connect the input power supply to the PVIN and GND terminals. Make sure that the PVIN DC input voltage will not exceed 60V.
4. Connect the PWM terminal. If PWM is not used, connect PWM to a 5V source or to INTV_{CC} on the PCB using 0Ω resistor R22. PWM must be pulled high to run.
5. Turn the input power supply on and make sure the voltage is between 4.7V and 60V.
6. Release the EN/UVLO to GND connection.
7. Observe the LED string running at the programmed LED current.
8. For PWM dimming, connect a PWM (100Hz or higher is recommended) signal to the PWM terminal. For analog dimming, connect a DC voltage between 0V and 2V to the CTRL terminal.
9. Observe the reduction of brightness in the LED string when PWM or analog dimming.

QUICK START PROCEDURE

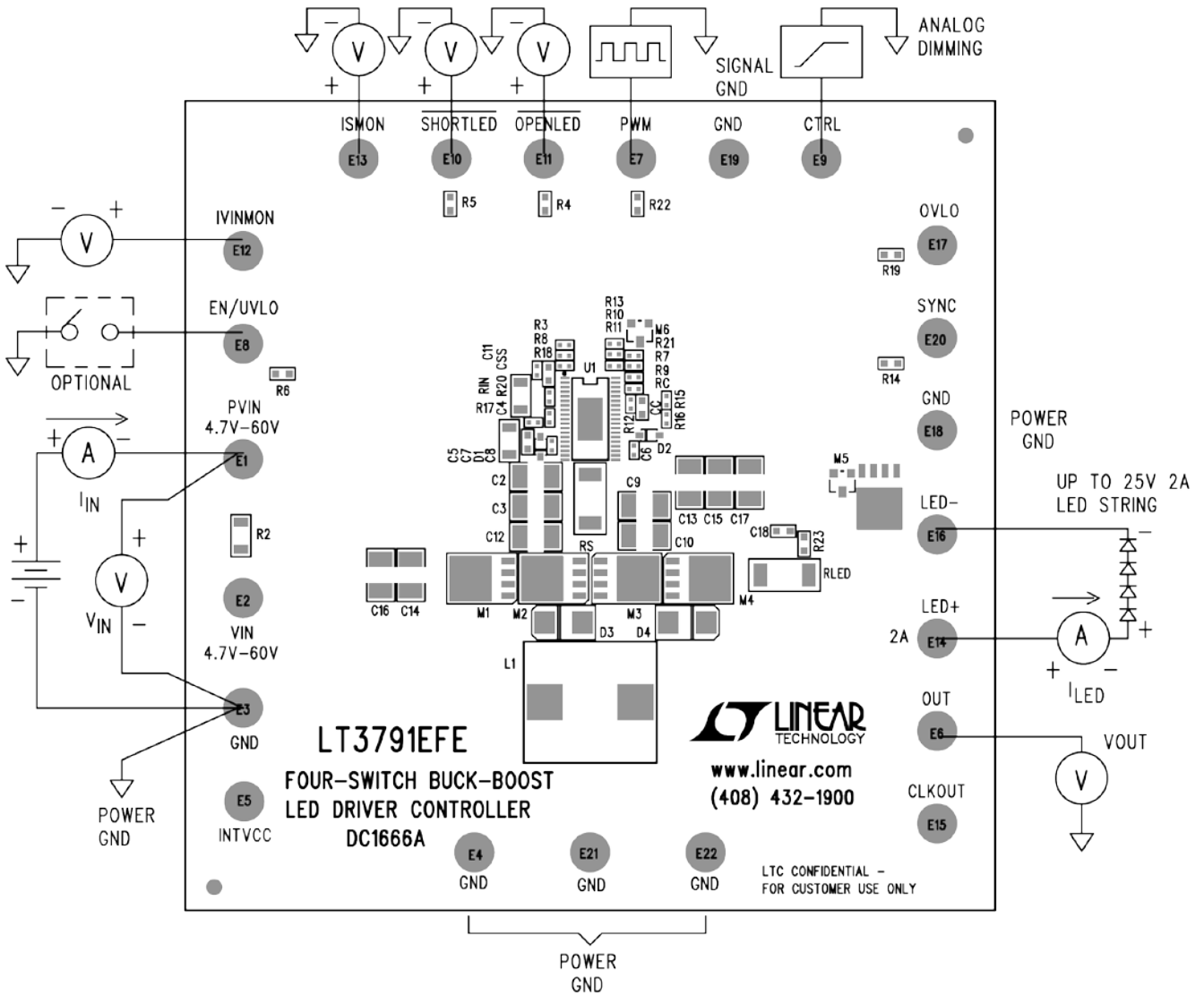

Figure 1. Test Procedure Setup Drawing for DC1666A

QUICK START PROCEDURE

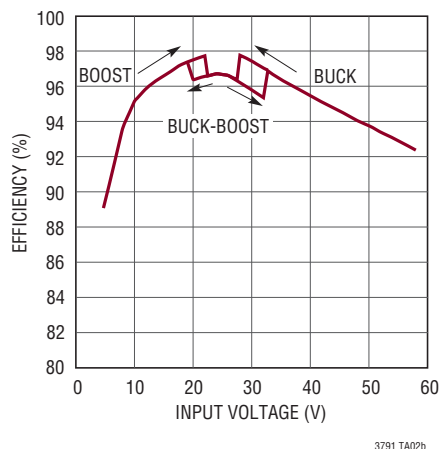

Figure 2. DC1666A Efficiency with 25V LEDs at 2A

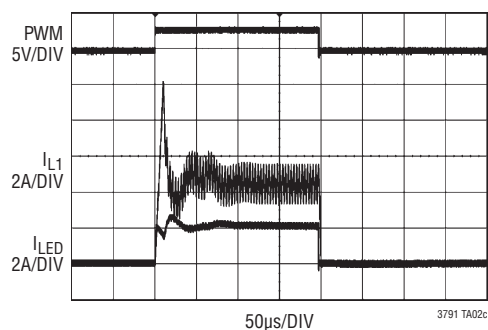

Figure 3. DC1666A 100Hz 50:1 PWM Dimming Waveforms at $12V_{IN}$ and $25V_{LED}$ at 2A

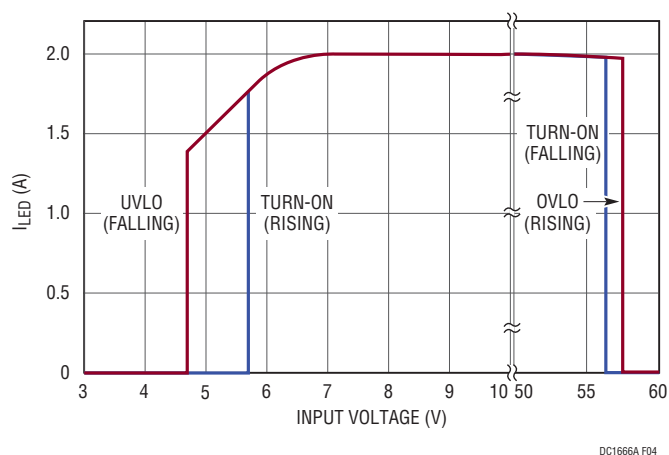
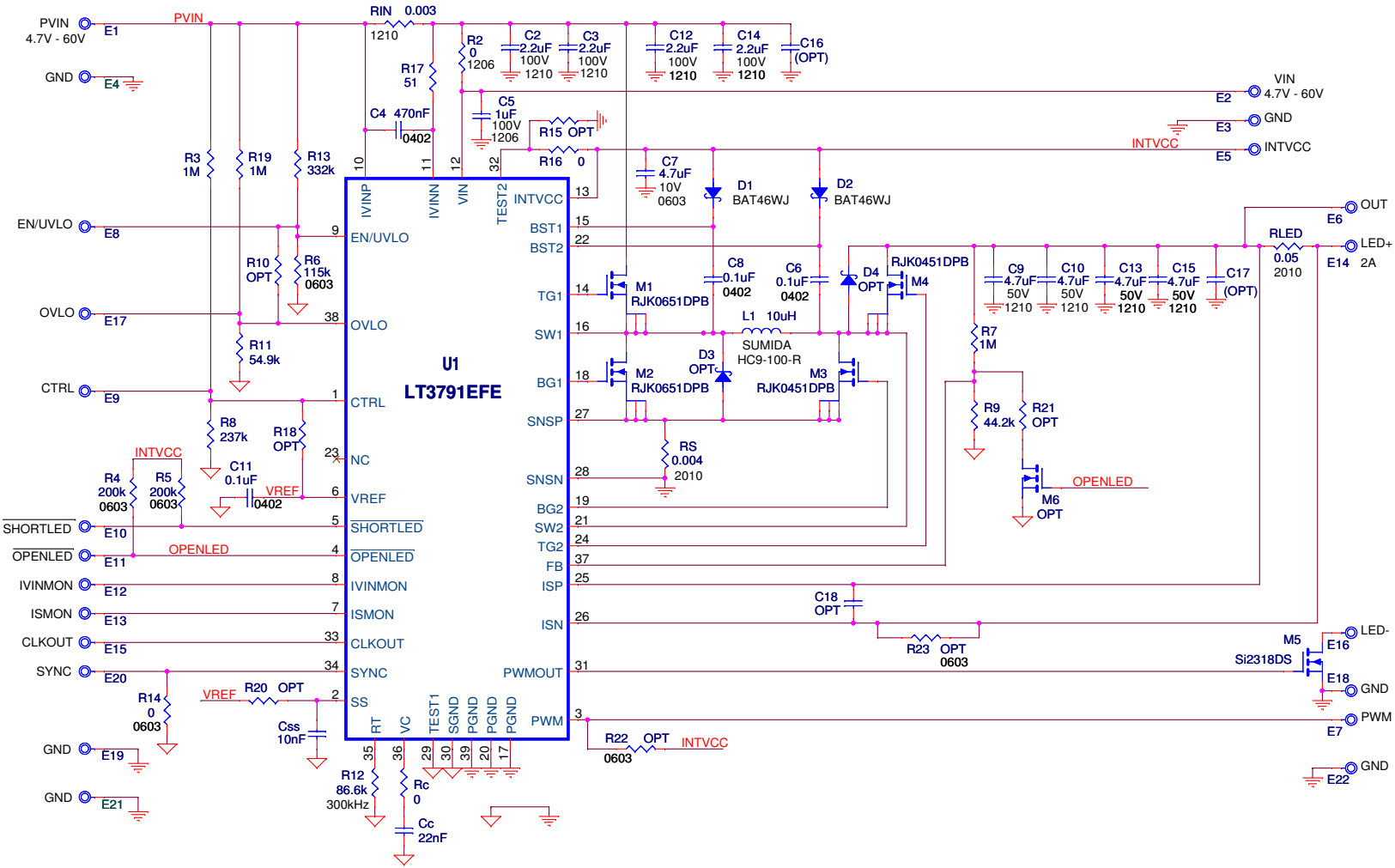

Figure 4. DC1666A CTRL LED Current Foldback at Low V_{IN} with UVLO Falling and Rising and OVLO

DEMO MANUAL DC1666A

PARTS LIST

ITEM	QTY	REFERENCE	PART DESCRIPTION	MANUFACTURER/PART NUMBER
Required Electrical Components				
1	1	C _{SS}	CAP X7R 0.01μF 50V 10% 0603	AVX, 06035C103KAT2A
2	1	C _C	CAP X7R 0.022μF 50V 10% 0603	AVX, 06035C223KAT2A 5%
3	4	C2, C3, C12, C14	CAP X7R 2.2μF 100V 10% 1210	AVX, 12101C225KAT2A
4	1	C5	CAP X7R 1μF 100V 10% 1206	AVX, 12061C105KAT2A
5	3	C6, C8, C11	CAP X5R 0.1μF 16V 10% 0402	AVX, 0402YD104KAT2A
6	1	C7	CAP X5R 4.7μF 10V 10% 0603	AVX, 0603ZD475KAT2A
7	4	C9, C10, C13, C15	CAP X7R 4.7μF 50V 10% 1210	AVX, 12105C475KAT2A
8	2	D1-D2	DIODE Single Schottky Barrier Diode SOD-323	NXP, BAT46WJ
9	1	L1	INDUCTOR 10μH	Cooper Bussmann, HC9-100-R
10	2	M1, M2	MOSFET N-Channel 60V LPAK	RENESAS, RJK0651DPB-00-J5
11	2	M3, M4	MOSFET N-Channel 40V LPAK	RENESAS, RJK0451DPB-00-J5
12	1	M5	MOSFET N-Channel 40V SOT-23	VISHAY, Si2318DS-T1-E3
13	1	R _{LED}	RES CHIP 0.050Ω 1% 2010	VISHAY, WSL2010R0500FEA
14	1	R _S	RES CHIP 0.004Ω 1W 1% 2010	VISHAY, WSL20104L000FEA
15	1	R7	RES CHIP 1M 1% 0402	VISHAY, CRCW04021M00FKED
16	1	R9	RES CHIP 44.2k 1% 0402	VISHAY, CRCW040244K2FKED
17	1	R12	RES CHIP 86.6k 1% 0402	VISHAY, CRCW040286K6FKED
18	1	U1	IC LT3791EFE 38-LEAD TSSOP VERSION AA TSSOP	LINEAR, LT3791EFE#PBF
Optional Electrical Components				
1	1	C4	CAP X5R 0.47μF 6.3V 10% 0402	AVX, 04026D474KAT2A
2	0	C16, C17	CAP 1210	OPTIONAL
3	0	C18	CAP 0603	OPTIONAL
4	0	D3, D4	DIODE SMB	OPTIONAL
5	2	R _C , R16	RES CHIP 0Ω 0402	VISHAY, CRCW04020000Z0ED
6	1	R _{IN}	RES CHIP 0.003Ω 1W 1% 1206	IRC, ULR-G-1-1206-R003-1-LF-SLT
7	1	R2	RES CHIP 0Ω 1206	VISHAY, CRCW12060000Z0EA
8	1	R3	RES CHIP 1M 1% 0402	VISHAY, CRCW04021M00FKED
9	2	R4, R5	RES CHIP 200k 5% 0603	VISHAY, CRCW0603200KJNEA
10	1	R6	RES CHIP 115k 1% 0603	VISHAY, CRCW0603115KFKEA
11	1	R8	RES CHIP 237k 1% 0402	VISHAY, CRCW0402237KFKED
12	0	R10, R15, R18, R20, R21	RES CHIP 0402Ω 0402	OPTIONAL
13	1	R11	RES CHIP 54.9k 1% 0402	VISHAY, CRCW040254K9FKED
14	1	R13	RES CHIP 332k 1% 0402	VISHAY, CRCW0402332KFKED
15	1	R14	RES CHIP 0Ω 0603	VISHAY, CRCW06030000Z0EA
16	1	R17	RES CHIP 51Ω 5% 0402	VISHAY, CRCW040251R0JNED
17	1	R19	RES CHIP 1M 1% 0603	VISHAY, CRCW06031M00FKED
18	0	R22, R23	RES CHIP 0Ω 0603	OPTIONAL
Hardware				
1	22	E1-E22	TURRET 0.095	MILL-MAX, 2501-2-00-80-00-00-07-0



SCHEMATIC DIAGRAM

DEMO MANUAL DC1666A

NOTE: UNLESS OTHERWISE SPECIFIED
 ALL CAPACITORS ARE 0603.
 ALL RESISTORS ARE 0402.

DEMO MANUAL DC1666A

DEMONSTRATION BOARD IMPORTANT NOTICE

Linear Technology Corporation (LTC) provides the enclosed product(s) under the following **AS IS** conditions:

This demonstration board (DEMO BOARD) kit being sold or provided by Linear Technology is intended for use for **ENGINEERING DEVELOPMENT OR EVALUATION PURPOSES ONLY** and is not provided by LTC for commercial use. As such, the DEMO BOARD herein may not be complete in terms of required design-, marketing-, and/or manufacturing-related protective considerations, including but not limited to product safety measures typically found in finished commercial goods. As a prototype, this product does not fall within the scope of the European Union directive on electromagnetic compatibility and therefore may or may not meet the technical requirements of the directive, or other regulations.

If this evaluation kit does not meet the specifications recited in the DEMO BOARD manual the kit may be returned within 30 days from the date of delivery for a full refund. **THE FOREGOING WARRANTY IS THE EXCLUSIVE WARRANTY MADE BY THE SELLER TO BUYER AND IS IN LIEU OF ALL OTHER WARRANTIES, EXPRESSED, IMPLIED, OR STATUTORY, INCLUDING ANY WARRANTY OF MERCHANTABILITY OR FITNESS FOR ANY PARTICULAR PURPOSE. EXCEPT TO THE EXTENT OF THIS INDEMNITY, NEITHER PARTY SHALL BE LIABLE TO THE OTHER FOR ANY INDIRECT, SPECIAL, INCIDENTAL, OR CONSEQUENTIAL DAMAGES.**

The user assumes all responsibility and liability for proper and safe handling of the goods. Further, the user releases LTC from all claims arising from the handling or use of the goods. Due to the open construction of the product, it is the user's responsibility to take any and all appropriate precautions with regard to electrostatic discharge. Also be aware that the products herein may not be regulatory compliant or agency certified (FCC, UL, CE, etc.).

No License is granted under any patent right or other intellectual property whatsoever. **LTC assumes no liability for applications assistance, customer product design, software performance, or infringement of patents or any other intellectual property rights of any kind.**

LTC currently services a variety of customers for products around the world, and therefore this transaction **is not exclusive**.

Please read the DEMO BOARD manual prior to handling the product. Persons handling this product must have electronics training and observe good laboratory practice standards. **Common sense is encouraged.**

This notice contains important safety information about temperatures and voltages. For further safety concerns, please contact a LTC application engineer.

Mailing Address:

Linear Technology
1630 McCarthy Blvd.
Milpitas, CA 95035

Copyright © 2004, Linear Technology Corporation