



Chipsmall Limited consists of a professional team with an average of over 10 year of expertise in the distribution of electronic components. Based in Hongkong, we have already established firm and mutual-benefit business relationships with customers from,Europe,America and south Asia,supplying obsolete and hard-to-find components to meet their specific needs.

With the principle of “Quality Parts,Customers Priority,Honest Operation,and Considerate Service”,our business mainly focus on the distribution of electronic components. Line cards we deal with include Microchip,ALPS,ROHM,Xilinx,Pulse,ON,Everlight and Freescale. Main products comprise IC,Modules,Potentiometer,IC Socket,Relay,Connector.Our parts cover such applications as commercial,industrial, and automotives areas.

We are looking forward to setting up business relationship with you and hope to provide you with the best service and solution. Let us make a better world for our industry!



## Contact us

Tel: +86-755-8981 8866 Fax: +86-755-8427 6832

Email & Skype: info@chipsmall.com Web: www.chipsmall.com

Address: A1208, Overseas Decoration Building, #122 Zhenhua RD., Futian, Shenzhen, China



LT3797EUKG  
Triple LED Boost Controller

## DESCRIPTION

DC1784B is a triple boost LED driver featuring the LT3797 triple boost LED controller. It accepts an input voltage from 2.5V to 40V (with higher transient) and drives three independent strings of up to 50V LEDs at 1A. DC1784B features independent PWM and analog dimming of each of the three LED strings. Each of the three channels has its own short-circuit protection, open LED protection, and FAULT flag output.

Each or every channel can be altered to run as a different topology such as buck-boost mode, buck mode, or SEPIC depending upon the relationship between input and output voltage. Although the boost is set up to power 50V of LEDs at 1A, the maximum LED string voltage can be changed to almost 100V and the LED current can be adjusted by merely changing a few resistors and external components.

DC1784B features high efficiency at 310kHz switching frequency. At high LED string voltages up to 50V and 1A of LED current, the triple LED boost controller has 93.5% efficiency. The switching frequency can be adjusted between 100kHz and 1MHz with a single resistor. All three channels run in-phase with each other and an external SYNC pin can be used to set the switching frequency and phasing, as well as to optimize PWM dimming.

For low input voltage operation, down to 2.5V, the CTRL pin voltage is reduced as the input voltage drops below 10.5V, reducing LED brightness and restraining the peak switch currents in order to limit thermal rise on this PCB. The LT3797 has a unique, internal buck-boost INTV<sub>CC</sub> supply that powers the gate drivers at 7.8V, regardless of the state of the input voltage, rather than using an LDO from the input. UVLO turns the LEDs off when V<sub>IN</sub> drops below 2.5V. Internal OVLO turns off the switching when

the input exceeds 41V, but OVLO can be programmed externally to a lower voltage if desired. The LT3797 can withstand transients up to 60V. DC1784A can withstand transients up to 50V with C3 > 50V rating.

Small ceramic input and output capacitors are used to save space and cost. The open LED overvoltage protection uses the IC's constant voltage regulation loop to regulate the output to approximately 55V if the LED string is opened although it may reach 59V peak during transient from running LEDs to open. The unique FBH (feedback high) pins allow the overvoltage protection of non-grounded LED driver topologies such as buck-boost mode and buck mode to be accomplished with just two resistors.

Modifications can be made to DC1784B in order to convert the independent channels to higher or lower power or from LED drivers to constant voltage regulators. They can easily be changed from boost topology to SEPIC, buck mode, or buck-boost mode LED drivers. Please consult the factory or the LT3797 data sheet for details.

The LT3797 data sheet gives a complete description of the device, operation and applications information. The data sheet must be read in conjunction with this demo manual for DC1784B. The LT3797EUKG is assembled in a 52-lead (7mm × 8mm) plastic QFN UKG package with a thermally enhanced ground pad. Proper board layout is essential for maximum thermal performance. See the data sheet section 'Layout Considerations'.

**Design files for this circuit board are available at <http://www.linear.com/demo/DC1784B>**

LT, LT, LTC, LTM, Linear Technology and the Linear logo are registered trademarks of Analog Devices, Inc. All other trademarks are the property of their respective owners.

## PERFORMANCE SUMMARY

PARAMETER	CONDITIONS	VALUE (TYPICAL)
Input Voltage PVIN Range	Operating $V_{IN} = PVIN$	2.5V to $V_{LED}$ (Up to 40V)
Switching Frequency	$R1 = 47.5k$	310kHz
$I_{LED}$ CH1, CH2, CH3	$R2, R3, R4 = 0.25\Omega$ $10.5V < PVIN < V_{LED}$ (40V)	1.0A
Low PVIN $I_{LED}$ (CTRL foldback)	$R2, R3, R4 = 0.25\Omega$ $PVIN = 4.0V$ $R2, R3, R4 = 0.25\Omega$ $PVIN = 6.0V$ $R2, R3, R4 = 0.25\Omega$ $PVIN = 9.0V$	280mA 525mA 890mA
$V_{LED}$ Range CH1, CH2, CH3	$R8, R9, R10 = 23.2k$ $R14, R15, R16 = 1M$	$PVIN < V_{LED} < 50V$
Open LED Voltage CH1, CH2, CH3	$R8, R9, R10 = 23.2k$ $R14, R15, R16 = 1M$	55V
Typical Efficiency (100% PWM Duty Cycle)	$PVIN = 14V$ $V_{LED} = 50V$ and $I_{LED} = 1A$ CH1, CH2, CH3	93.5%
PVIN Under Voltage Lockout (Falling Turn-Off)	$R26 = 100k$ and $R27 = 105k$	2.5V
PVIN Under Voltage Lockout (Rising Turn-On)	$R26 = 100k$ and $R27 = 105k$	2.6V
INTV <sub>CC</sub>	Operating	7.5V
Peak Switch Current Limit CH1, CH2, CH3	$R11, R12, R13 = 0.008\Omega$	12.5A

## QUICK START PROCEDURE

DC1784B is easy to set up to evaluate the performance of the LT3797EUKG. Follow the procedure below:

1. Connect three strings of LEDs that will run with forward voltage less than 50V (at 1A), but greater than PVIN, to the LED<sup>+</sup> and GND terminals on the PCB as shown in Figure 1.
2. Connect the EN/UVLO terminal to GND.
3. With power off, connect the input power supply to the PVIN and GND terminals. Make sure that the PVIN DC input voltage does not exceed 40V (or  $V_{LED}$ ).
4. Turn the input power supply on and make sure the voltage is between 2.5V and 40V (or  $V_{LED}$ ).
5. Connect the PWM1-3 input terminals to INTV<sub>CC</sub> or  $V_{REF}$  to enable 100% brightness control when EN/UVLO is released.
6. Release the EN/UVLO-to-GND connection.
7. Observe the LED strings running at the programmed LED current.
8. To change the brightness with analog dimming, simply attach a voltage source on any or all of the CTRL terminals and set the voltage(s) between 0V and 1.5V. See data sheet for details.
9. To change brightness with PWM dimming, remove the connection from PWM1-3 to INTV<sub>CC</sub> or  $V_{REF}$  and attach a 3.3V to 5V rectangular waveform with varying duty cycle.

## DEMO CIRCUIT OPTIONS

DC1784B can be adjusted for higher output voltage, different LED current, or different topology. The following options are for simple changes to the demonstration circuit. The data sheet gives more information regarding designing with the LT3797. For more information, see the data sheet for details or contact Linear Technology technical support.

### Maximum LED Voltage

DC1784B is set for 55V of overvoltage protection and the maximum LED string voltage used on the standard build should be 50V. However, the output can go up to 100V, so OVP can be set at about 93V for maximum LED voltage and the maximum LED string voltage is therefore about 87V. The limits are based upon open LED overshoot and voltage and current regulation regions. If changes are made in the FB resistors for higher voltage, the MOSFET and catch diode should be switched out for higher voltage devices. See the LT3797 data sheet for details.

### Current or Voltage Regulation

The LT3797 can be used for constant current or voltage regulation. If the load placed on the LED<sup>+</sup> to GND terminals allows  $V_{OUT}$  to climb high enough for  $V_{ISP-FBH} = 1.2V$ , then the voltage regulation loop of the converter takes over. In this case, the compensation for a given channel should be adjusted for proper use as a constant voltage regulator. The IC can be used as a boost or SEPIC constant voltage regulator. Output voltage can be almost as high as 100V when used as a constant voltage regulator.

### LED Current and Switch Current

LED current on DC1784B is set for 1A with 0.25Ω resistors R2, R3, R4. For a different maximum LED current, change this resistor:

$$250\text{mV}/R_{LED} = I_{LED}$$

A change in LED current or input voltage may lead to higher or lower maximum switch current. R11, R12, R13 can be changed to alter the maximum switch current for different applications.  $100\text{mV}/R_{SENSE} = \text{peak switch current}$ .

### Overvoltage Protection

Overvoltage protection is set with resistor pairs R8 & R14, R9 & R15, R10 & R16. The high side feedback method allows simple changes for different topologies.

For buck mode and buck-boost mode, see the data sheet for details how to set the feedback resistors. Note that R35, R36, R37 are provided as optional placeholders on the demo circuit for simple feedback resistor changes for these topologies.

### BOOST, BUCK MODE, BUCK-BOOST MODE, SEPIC

Any channel of the DC1784B can be changed to a different topology than boost. A few simple changes including feedback overvoltage protection feedback resistors, output resistor, components, and connection to input can be made. Please consult the LT3797 data sheet and the factory for details.

### Undervoltage and Overvoltage Lockout

UVLO can be adjusted by changing the values of R26 and R27.

The LT3797 has an internal 41V OVLO that protects the IC from switching at high input voltage transients. However, an additional OVLO pin can be used to set a lower OVLO using resistors R28, R31, and/or R46.

# DEMO MANUAL DC1784B

## DEMO CIRCUIT OPTIONS

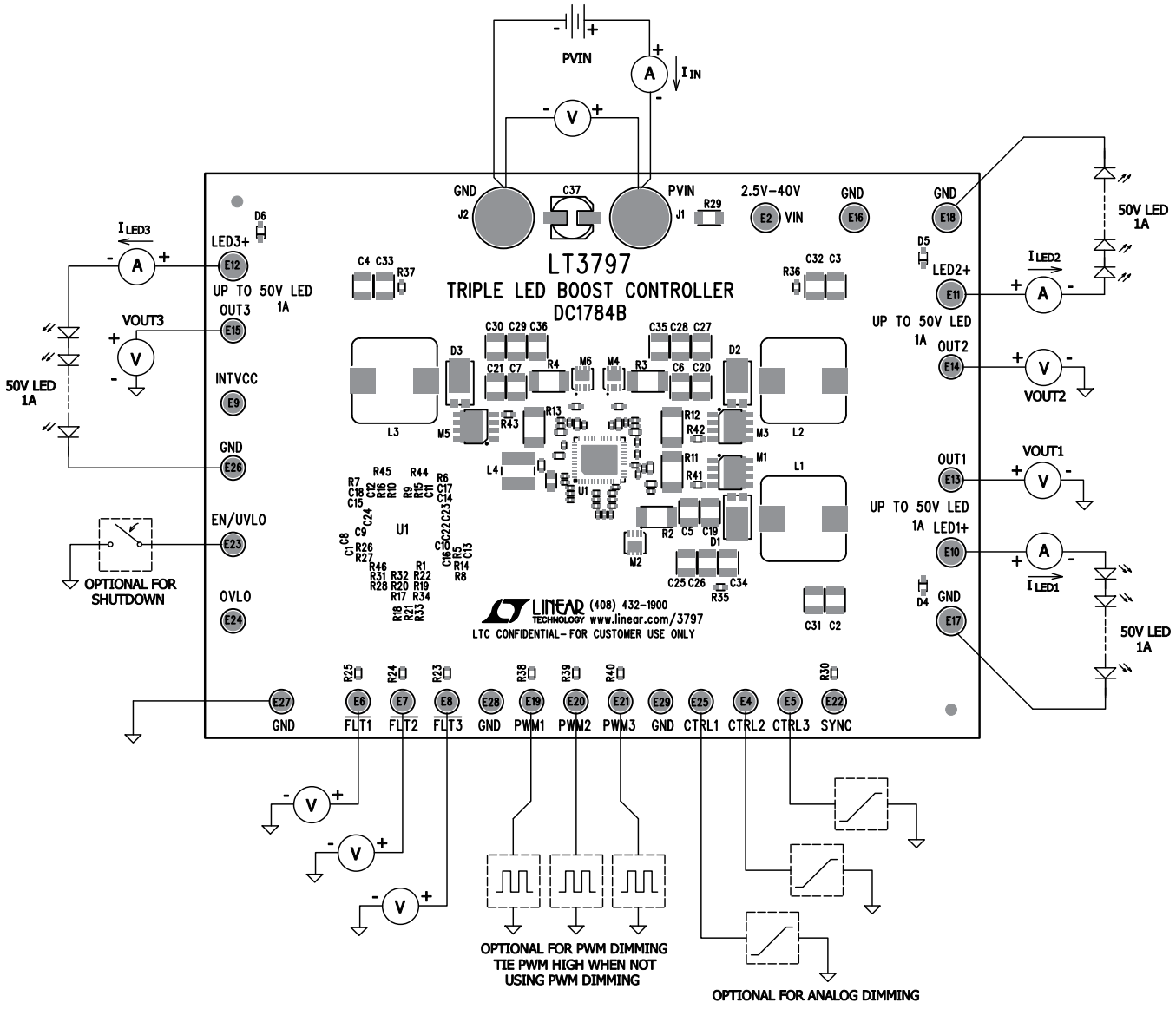

Figure 1. Test Procedure Setup Drawing for DC1784B

## DEMO CIRCUIT OPTIONS

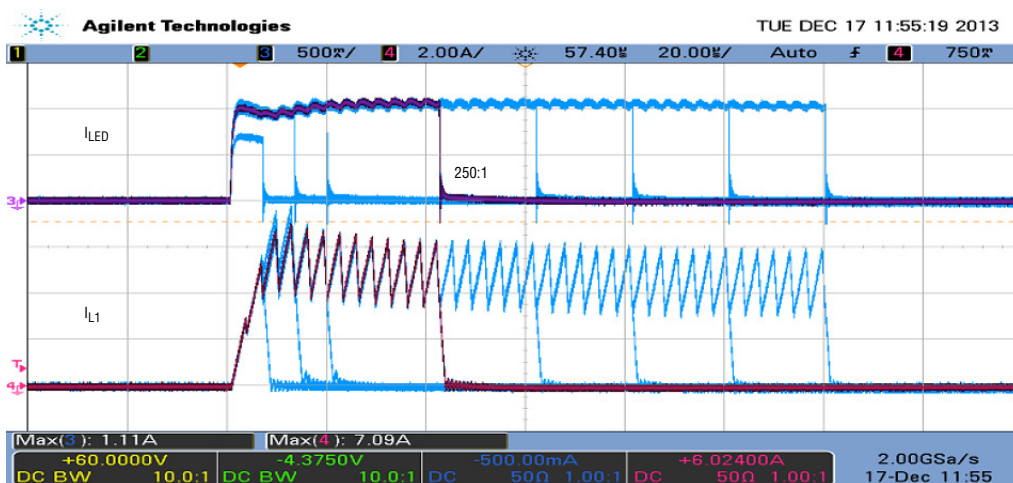

Figure 2. DC1784B 12V<sub>IN</sub> 100Hz PWM Dimming Waveforms at Different PWM Duty Cycles with 250:1 in Bold. I<sub>LED</sub> Waveform (500mA/Div) Is on Top (with 50V LED String) and I<sub>L1</sub> Waveform (2A/Div) Is on the Bottom

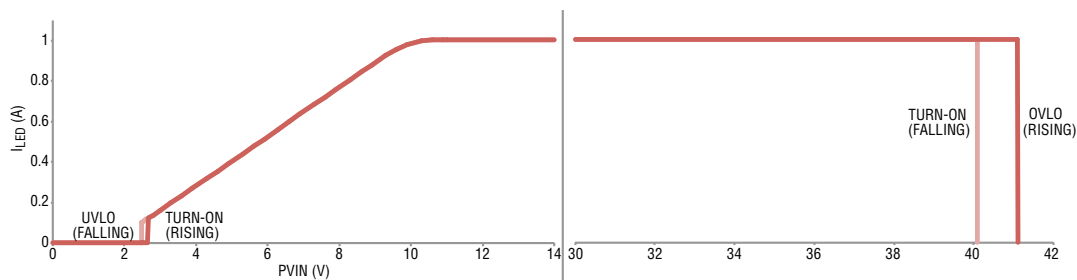

Figure 3. DC1784B CTRL LED Current Foldback at Low P<sub>VIN</sub> with UVLO Falling and Rising

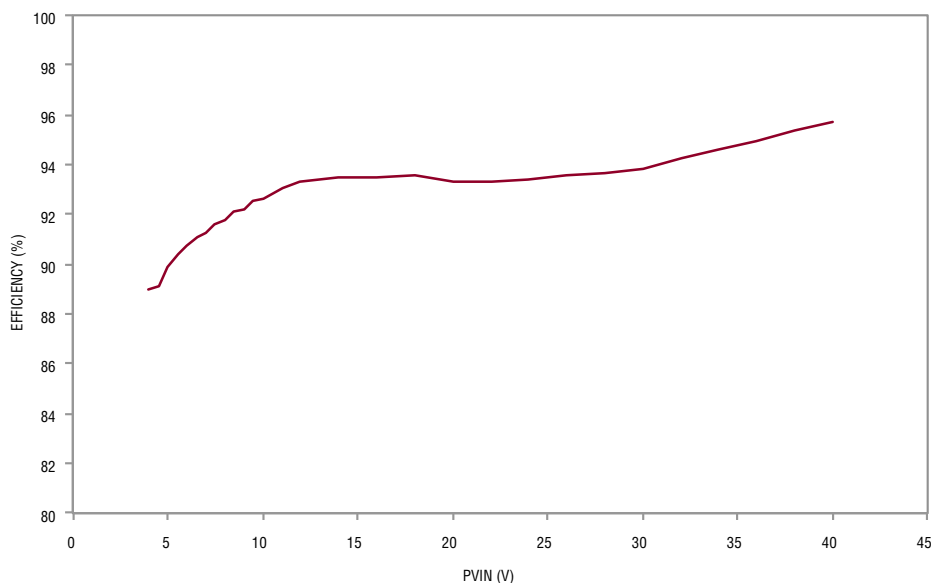
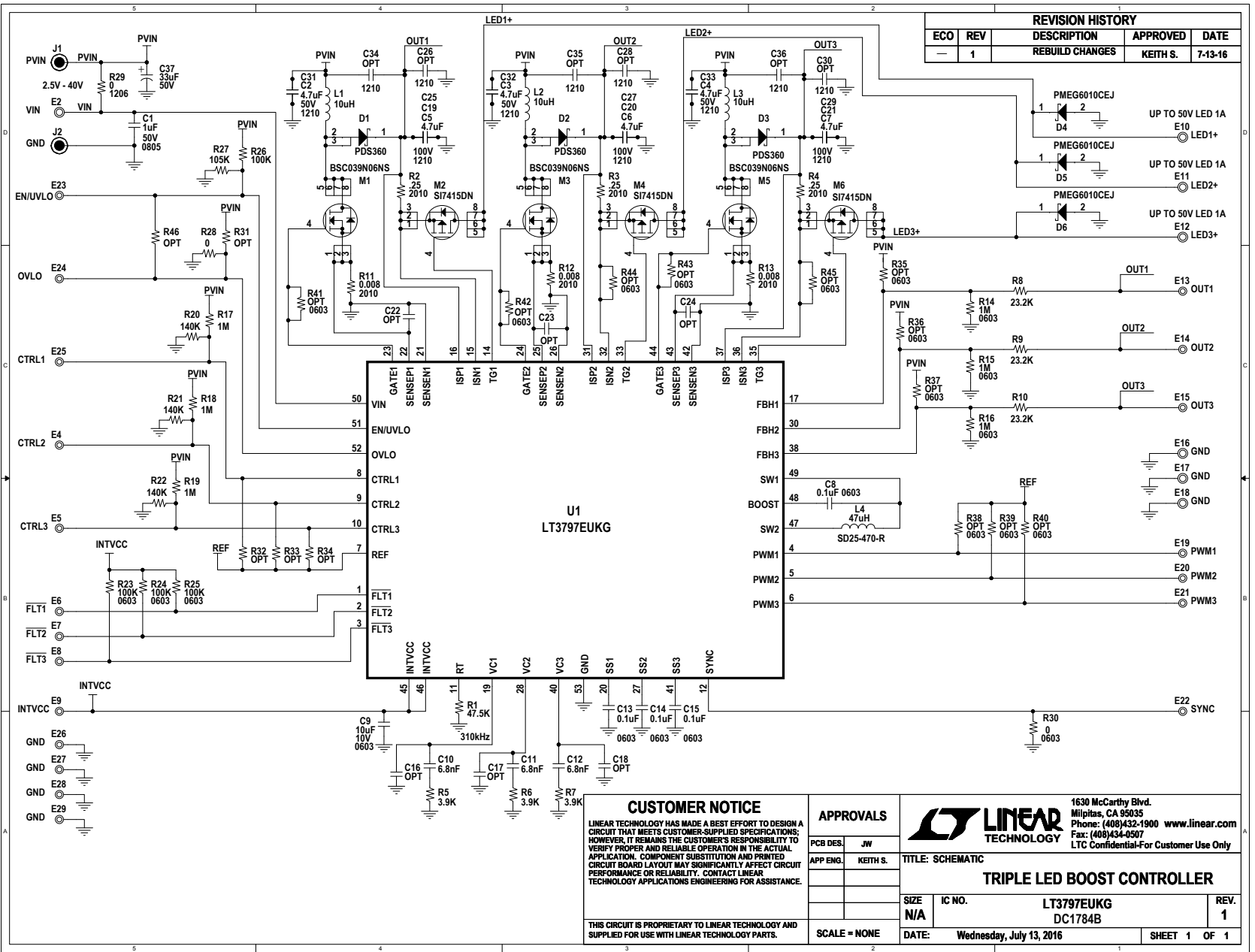

Figure 4. DC1784B Efficiency at Maximum I<sub>LED</sub> vs P<sub>VIN</sub> with 50V LEDs (at 1A) on All Three Channels

# DEMO MANUAL DC1784B

## PARTS LIST

ITEM	QTY	REFERENCE	PART DESCRIPTION	MANUFACTURER/PART NUMBER
<b>Required Circuit Components</b>				
1	1	C1	Cap., X7R, 1 $\mu$ F, 50V, 10%, 0805	MURATA, GRM21BR71H105KA12L
2	6	C2, C3, C4, C31, C32, C33	Cap., X7R, 4.7 $\mu$ F, 50V, 10%, 1210	MURATA, GRM32ER71H475KA88L
3	9	C5, C6, C7, C19, C20, C21, C25, C27, C29	Cap., X7S, 4.7 $\mu$ F, 100V, 20%, 1210	TDK C3225X7S2A475M
4	4	C8, C13, C14, C15	Cap., X7R, 0.1 $\mu$ F, 10V, 10%, 0603	AVX, 0603ZC104KAT2A
5	1	C9	Cap., X5R, 10 $\mu$ F, 10V, 20%, 0603	SAMSUNG CL10A106MP8NUNC
6	3	C10, C11, C12	Cap., X7R, 6800pF, 25V, 10%, 0402	AVX, 04023C682KAT2A
7	3	D1, D2, D3	DIODE, PDS360, POWERDI-5	DIODES/ZETEX, PDS360-13
8	3	L1, L2, L3	IND, 10 $\mu$ H, HC9-100-R	COILTRONICS, HC9-100-R
9	1	L4	IND., 47 $\mu$ H, SD SERIES, IND-SD25	COILTRONICS, SD25-470-R
10	3	M1, M3, M5	Mosfet, N-Channel, BSC039N06NS, PWRPAK SO-8	INFINEON, BSC039N06NS
11	3	M2, M4, M6	Mosfet, P-Channel, SI7415DN, PWRPAK1212-8	VISHAY, SI7415DN-T1-GE3
12	1	R1	RES., CHIP, 47.5k, 1/16W, 1%, 0402	VISHAY, CRCW040247K5FKED
13	3	R2, R3, R4	RES., CHIP, 0.25 $\Omega$ , 1W, 1%, 2010	IRC, LRC-LR2010LF-01-R250-F
14	3	R5, R6, R7	RES., CHIP, 3.9k, 1%, 0402	VISHAY, CRCW04023K90FKED
15	3	R8, R9, R10	RES., CHIP, 23.2k, 1/16W, 1%, 0402	VISHAY, CRCW040223K2FKED
16	3	R11, R12, R13	RES., CHIP, 0.008 $\Omega$ , 1W, 1%, 2010	SEI, CSRF2010FT8L00
17	3	R14, R15, R16	RES., CHIP, 1M, 1/10W, 1%, 0603	VISHAY, CRCW06031M00FKEA
18	1	U1	IC, LT3797EUKG QFN(52)(UKG)-7mm x 8mm	LINEAR TECH.CORP. LT3797EUKG#PBF
<b>Optional Electrical Components</b>				
1	0	C16, C17, C18, C22, C23, C24	CAP., OPT 0402	OPT
2	0	C26, C28, C30, C34, C35, C36	CAP., OPT 1210	OPT
3	1	C37	Cap., ALUM, 33 $\mu$ F, 50V, 6.3 x 7.7	PANASONIC, EEHZA1H330XP
4	3	D4, D5, D6	DIODE, PMEG6010CEJ	NXP, PMEG6010CEJ
5	3	R17, R18, R19	RES., CHIP, 1M, 1/16W, 1%, 0402	VISHAY, CRCW04021M00FKED
6	3	R20, R21, R22	RES., CHIP, 140k, 1/16W, 1%, 0402	VISHAY, CRCW0402140KFKED
7	3	R23, R24, R25	RES., CHIP, 100k, 1/10W, 1%, 0603	VISHAY, CRCW0603100KFKEA
8	1	R26	RES., CHIP, 100k, 1/16W, 1%, 0402	VISHAY, CRCW0402100KFKED
9	1	R27	RES., CHIP, 105k, 1/16W, 1%, 0402	VISHAY, CRCW0402105KFKED
10	1	R28	RES., CHIP, 0 $\Omega$ , 0402	VISHAY, CRCW04020000Z0ED
11	1	R29	RES., CHIP, 0 $\Omega$ , 1/4W, 1%, 1206	VISHAY, CRCW12060000Z0EA
12	1	R30	RES., CHIP, 0 $\Omega$ , 1/10W, 1%, 0603	VISHAY, CRCW06030000Z0EA
13	0	R31 to R34, R46	RES., OPT, 0402	OPT
14	0	R35 to R45	RES., OPT, 0603	OPT
<b>Hardware</b>				
1	7	E2, E10, E11, E12, E16, E17, E18	TESTPOINT, TURRET 0.094"	MILLMAX, 2501-2-00-80-00-00-07-0
2	20	E4 to E9, E13 to E15, E19 to E29	TESTPOINT, TURRET 0.064"	MILL-MAX, 2308-2-00-80-00-00-07-0
3	2	J1, J2	CONNECTOR, BANANA JACK	KEYSTONE, 575-4



<p><b>CUSTOMER NOTICE</b></p> <p>LINEAR TECHNOLOGY HAS MADE A BEST EFFORT TO DESIGN A CIRCUIT THAT MEETS CUSTOMER-SUPPLIED SPECIFICATIONS; HOWEVER, IT REMAINS THE CUSTOMER'S RESPONSIBILITY TO VERIFY PROPER AND RELIABLE OPERATION IN THE ACTUAL APPLICATION. COMPONENT SUBSTITUTION AND PRINTED CIRCUIT BOARD LAYOUT MAY SIGNIFICANTLY AFFECT CIRCUIT PERFORMANCE OR RELIABILITY. CONTACT LINEAR TECHNOLOGY APPLICATIONS ENGINEERING FOR ASSISTANCE.</p> <p>THIS CIRCUIT IS PROPRIETARY TO LINEAR TECHNOLOGY AND SUPPLIED FOR USE WITH LINEAR TECHNOLOGY PARTS.</p>		<p><b>APPROVALS</b></p> <table border="1"> <tr> <td>PCB DES.</td> <td>JW</td> </tr> <tr> <td>APP ENG.</td> <td>KEITH S.</td> </tr> </table> <p>SCALE = NONE</p>	PCB DES.	JW	APP ENG.	KEITH S.	<p><b>LINEAR TECHNOLOGY</b></p> <p>1630 McCarthy Blvd. Milpitas, CA 95035 Phone: (408)432-1900 www.linear.com Fax: (408)434-0507 LTC Confidential-For Customer Use Only</p> <p>TITLE: SCHEMATIC</p> <p><b>TRIPLE LED BOOST CONTROLLER</b></p> <table border="1"> <tr> <td>SIZE</td> <td>IC NO.</td> <td>REV.</td> </tr> <tr> <td>N/A</td> <td>LT3797EUKG DC1784B</td> <td>1</td> </tr> </table> <p>DATE: Wednesday, July 13, 2016</p> <p>SHEET 1 OF 1</p>	SIZE	IC NO.	REV.	N/A	LT3797EUKG DC1784B	1
PCB DES.	JW												
APP ENG.	KEITH S.												
SIZE	IC NO.	REV.											
N/A	LT3797EUKG DC1784B	1											



# DEMO MANUAL DC1784B

---

## DEMONSTRATION BOARD IMPORTANT NOTICE

Linear Technology Corporation (LTC) provides the enclosed product(s) under the following **AS IS** conditions:

This demonstration board (DEMO BOARD) kit being sold or provided by Linear Technology is intended for use for **ENGINEERING DEVELOPMENT OR EVALUATION PURPOSES ONLY** and is not provided by LTC for commercial use. As such, the DEMO BOARD herein may not be complete in terms of required design-, marketing-, and/or manufacturing-related protective considerations, including but not limited to product safety measures typically found in finished commercial goods. As a prototype, this product does not fall within the scope of the European Union directive on electromagnetic compatibility and therefore may or may not meet the technical requirements of the directive, or other regulations.

If this evaluation kit does not meet the specifications recited in the DEMO BOARD manual the kit may be returned within 30 days from the date of delivery for a full refund. **THE FOREGOING WARRANTY IS THE EXCLUSIVE WARRANTY MADE BY THE SELLER TO BUYER AND IS IN LIEU OF ALL OTHER WARRANTIES, EXPRESSED, IMPLIED, OR STATUTORY, INCLUDING ANY WARRANTY OF MERCHANTABILITY OR FITNESS FOR ANY PARTICULAR PURPOSE. EXCEPT TO THE EXTENT OF THIS INDEMNITY, NEITHER PARTY SHALL BE LIABLE TO THE OTHER FOR ANY INDIRECT, SPECIAL, INCIDENTAL, OR CONSEQUENTIAL DAMAGES.**

The user assumes all responsibility and liability for proper and safe handling of the goods. Further, the user releases LTC from all claims arising from the handling or use of the goods. Due to the open construction of the product, it is the user's responsibility to take any and all appropriate precautions with regard to electrostatic discharge. Also be aware that the products herein may not be regulatory compliant or agency certified (FCC, UL, CE, etc.).

No License is granted under any patent right or other intellectual property whatsoever. **LTC assumes no liability for applications assistance, customer product design, software performance, or infringement of patents or any other intellectual property rights of any kind.**

LTC currently services a variety of customers for products around the world, and therefore this transaction **is not exclusive**.

**Please read the DEMO BOARD manual prior to handling the product.** Persons handling this product must have electronics training and observe good laboratory practice standards. **Common sense is encouraged.**

This notice contains important safety information about temperatures and voltages. For further safety concerns, please contact a LTC application engineer.

Mailing Address:

Linear Technology  
1630 McCarthy Blvd.  
Milpitas, CA 95035

Copyright © 2004, Linear Technology Corporation