



Chipsmall Limited consists of a professional team with an average of over 10 year of expertise in the distribution of electronic components. Based in Hongkong, we have already established firm and mutual-benefit business relationships with customers from,Europe,America and south Asia,supplying obsolete and hard-to-find components to meet their specific needs.

With the principle of “Quality Parts,Customers Priority,Honest Operation,and Considerate Service”,our business mainly focus on the distribution of electronic components. Line cards we deal with include Microchip,ALPS,ROHM,Xilinx,Pulse,ON,Everlight and Freescale. Main products comprise IC,Modules,Potentiometer,IC Socket,Relay,Connector.Our parts cover such applications as commercial,industrial, and automotives areas.

We are looking forward to setting up business relationship with you and hope to provide you with the best service and solution. Let us make a better world for our industry!



Contact us

Tel: +86-755-8981 8866 Fax: +86-755-8427 6832

Email & Skype: info@chipsmall.com Web: www.chipsmall.com

Address: A1208, Overseas Decoration Building, #122 Zhenhua RD., Futian, Shenzhen, China



LTC2991 I²C Temperature, Voltage and Current Monitor

DESCRIPTION

Demonstration circuit 1785A features the LTC[®]2991, a high performance temperature, voltage and current monitor that uses an I²C interface for communication. It offers sub-millivolt voltage resolution, 1% current measurement and 1°C temperature accuracy.

DC1785A is a member of Linear Technology's QuikEval™ family of demonstration boards. It is designed to allow easy evaluation of the LTC2991 and may be connected directly to the target application's analog signals while using the DC590 USB Serial Controller board and supplied software

to measure performance. The exposed ground planes allow proper grounding to prototype circuitry. After evaluating with Linear Technology's software, the digital signals can be connected to the end application's processor/controller for development of the serial interface.

Design files for this circuit board are available at <http://www.linear.com/demo>

LT, LT, LTC, LTM, µModule, Linear Technology and the Linear logo are registered trademarks and QuikEval is a trademark of Linear Technology Corporation. All other trademarks are the property of their respective owners.

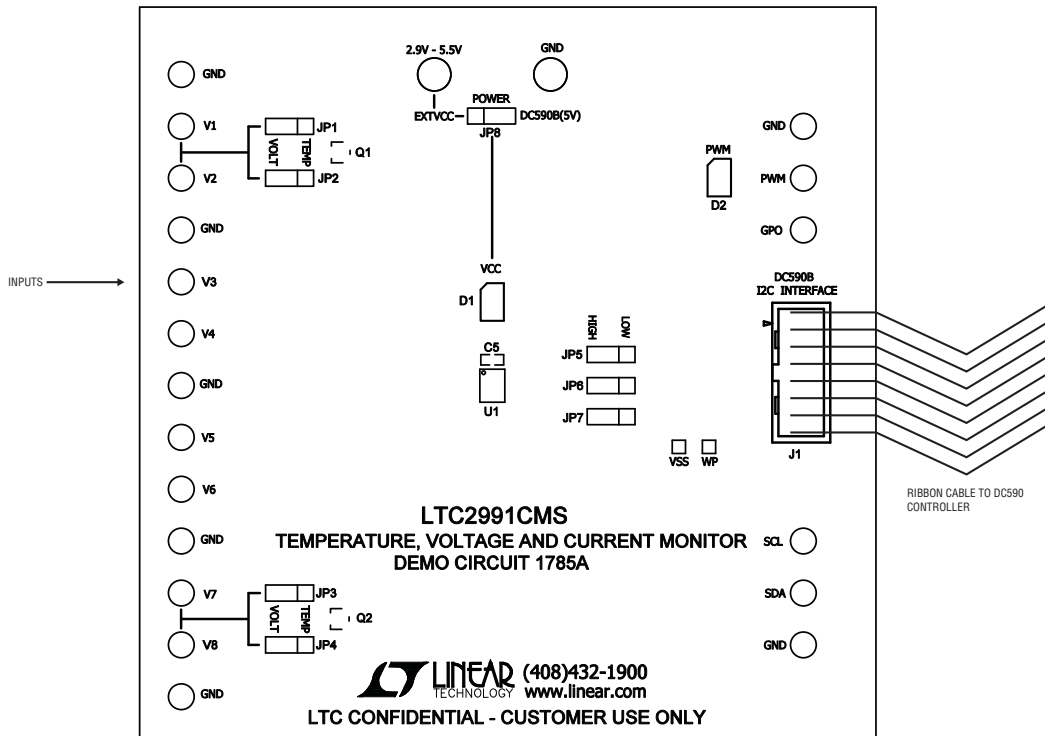

Figure 1. Proper Measurement Equipment Set-Up

QUICK START PROCEDURE

Connect the DC1785A to a DC590 USB Serial Controller using the supplied 14-conductor ribbon cable. Connect the DC590 to host PC with a standard USB A/B cable. Run the evaluation software supplied with DC590 or downloaded from <http://www.linear.com/software>. The correct program will be loaded automatically. Click the COLLECT button to start reading the input voltage. Details on software features are documented in the control panel's help menu.

SOFTWARE SET-UP

The DC1785A software is designed to give the user access to all LTC2991 functionality and features. There are several options that may be accessed both through right and left clicks.

Input Settings

By default, all eight inputs are set as single-ended. This may be modified by either left clicking the input type picture to cycle through the options or right clicking the picture to bring up a list of options and left clicking to select.

The legend for each input type icon is included below.

Single-Ended (default)	
Differential	
Diode Temperature	

Input sampling can also be turned on and off by left clicking the label of the corresponding input. When an input is off, the values box below the label will be shaded and the value will stop updating.

Graph Settings

By default, the QuikEval software will graph V1. To begin graphing a different input, left click the values box of the input to be graphed.

To pan the graph, hold down the right mouse button while hovering over the graph and move the mouse in the direction of desired motion. The graph will cease to auto-scroll after a pan has been initiated, to reactivate the auto-scroll double left click anywhere on the graph.

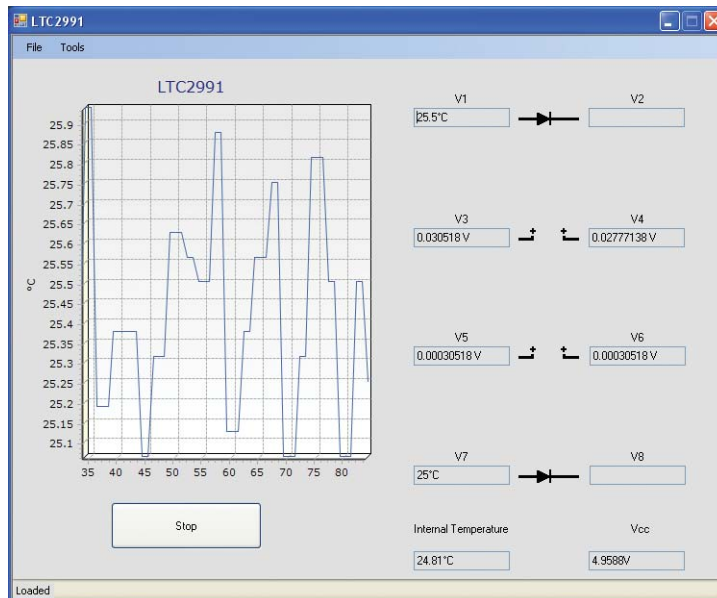

Figure 2. Software Screenshot

QUICK START PROCEDURE

To zoom the graph, left click and drag. To undo any zoom and re-initiate auto-scroll, double left click anywhere on the graph.

Tools

There are two tools included in the software package; both are accessible under the tools menu in the software.

Statistics: The statistics window lists some basic information about the gathered values. It gives, mean, standard deviation, min, max and crest factor. The statistics can be reset with the reset button.

PWM: The PWM window allows the user to configure the PWM functionality of the LTC2991. The DC1785A includes a red LED next to the PWM turret which reflects the duty cycle of the PWM pin. The pin needs to be enabled in this window in order for proper functionality to be achieved. This window also allows the user to set the PWM threshold. Please see the LTC2991 datasheet for an explanation of the PWM pin functionality.

HARDWARE SET-UP

Connection to DC590 Serial Controller

J1 is the power and digital interface connector. Connect to DC590 serial controller with supplied 14-conductor ribbon cable.

Jumper Settings

V1, V2, V7, V8 – (Default VOLT, VOLT, VOLT, VOLT). These jumpers can be toggled between VOLT and TEMP. VOLT connects the corresponding input on the LTC2991 with the corresponding turret for an external input. TEMP connects the corresponding input to MMBT (V1 and V2). Please note that the jumpers should be moved in pairs, V1 and V2 should both be connected either to VOLT or TEMP and V7 and V8 should also be both connected to either VOLT or TEMP. Once set the proper selection should also be made inside the QuikEval software in the mode selection box, to reflect any changes made.

V_{CC} – (Default DC590) $EXTV_{CC}$ allows the user to provide the V_{CC} voltage (2.9V to 5V) to the LTC2991 at turret $EXTV_{CC}$ while DC590(5V) powers the LTC2991 with 5V from the DC590. State of V_{CC} can be seen through red LED D1.

ADR0, ADR1, ADR2 – (Default LOW, LOW, LOW) These jumpers are used to select the I²C address for the LTC2991. When used with QuikEval, the correct address should also be selected from within the software.

Analog Connections

Analog signal connections are made via the row of turret posts along the edge of the board. Also, when connecting the board to an existing circuit the exposed ground planes along the edges of the board may be used to form a solid connection between grounds.

GND – (8 turrets) These turrets are connected directly to the internal ground planes.

$EXTV_{CC}$ – This turret allows the user to provide V_{CC} to the LTC2991. Select V_{CC} jumper accordingly.

V1, V2, V3, V4, V5, V6, V7, V8 – These turrets are used to provide input voltage to the monitor when the corresponding jumpers are set to the VOLT position.

Digital Connections

PWM – PWM output pin configurable through the QuikEval software. State of the PWM pin is reflected quantitatively through the PWM LED at D2.

SDA, SCL – I²C signals brought out to turrets. If DC1785A is to be run without a DC590 connected or with an alternative microprocessor, I²C signals can be driven at these points. If DC590 is not used R4 and R5 (Backside of board) can be populated with appropriate I²C pull-up values.

GPO – General purpose output pin can be toggled through QuikEval software.

DEMO MANUAL DC1785A

PARTS LIST

ITEM	QTY	REFERENCE	PART DESCRIPTION	MANUFACTURER/PART NUMBER
Required Circuit Components				
1	0	C1, C2, C3, C4 (OPT)	Capicitor, 0603	OPT
2	2	C5, C6	Capicitor, 0.1 μ F, 25V, X7R, 10%, 0603	TDK, C1608X7R1E104K (Bal to #1787A)
3	1	D1	LED, Red, J-Type, SMD, Tape/Reel, 1208	Panasonic, LN1251CTR
4	1	D2	LED, Green, J-Type, SMD, Tape/Reel, 1208	Panasonic, LN1351CTR
5	19	E1-E13, E16-E21	Turret, Testpoint, 0.065	Mill-Max, 2308-2-00-80-00-00-07-0
6	2	E14, E15	Turret, Testpoint, 0.095	Mill-Max, 2501-2-00-80-00-00-07-0
7	8	JP1-JP8	Header, 3-Pin, 0.079, Single Row	Samtec, TMM-103-02-L-S
8	1	J1	Connector, Header 14POS 2mm Vert Gold	Molex, 87831-1420
9	1	Q1	Transistor, PNP, -40V, -200MA, SOT23-3	Diodes/Zetex, FMMT3906TA
10	1	Q2	Transistor, NPN, 40V, 350MW, SMD, SOT23-3	Diodes Inc., MMBT3904-7-F
11	1	Q3	MOSFET, N-Channel, 60V, 115mA, SOT23-3	Diodes/Zetex, 2N7002TA
12	3	R1, R2, R3	Resistor, Chip 4.99k, 0.06W, 1%, 0603	Yageo, RC0603FR-074K99L
13	0	R4, R5 (OPT)	Resistor, 0603	OPT
14	2	R6, R7	Resistor, Chip, 330 Ω , 0.06W, 5%, 0603	Yageo, RC0603JR-07330RL
15	2	R8, R9 Bal to #1765A	Resistor, Chip, 1k, 0.06W, 5%, 0603	Yageo, RC0603JR-071KL
16	2	TP1, TP2	Testpoint, Test pad	Component Corp., TP-107-02-1
17	1	U1	IC, Temperature, Voltage, Current Monitor MSOP(16)-MS	Linear Technology, LTC2991CMS#PBF
18	1	U2	IC, EEPROM, 2kbit, 400Khz, TSSOP-8	Microchip, 24LC025-I/ST
19	8	XJP1-XJP8	Shunt, .079" Center	Samtec, 2SN-BK-G

REVISION HISTORY				
ECO	REV	DESCRIPTION	APPROVED	DATE
-	2	PRODUCTION	LEO C	04/25/11

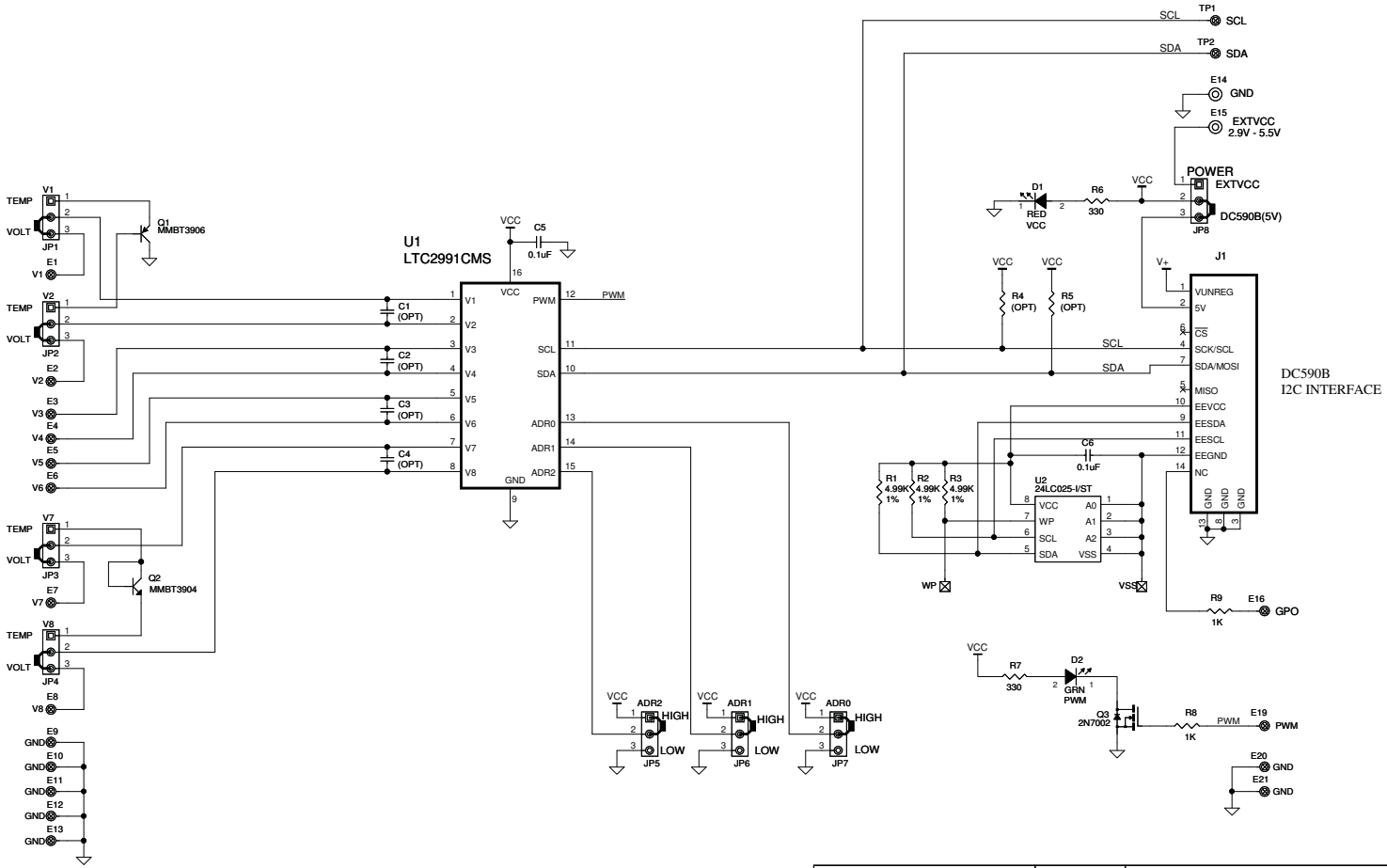

- NOTE: UNLESS OTHERWISE SPECIFIED.
1. ALL RESISTORS ARE IN OHMS, 0603.
ALL CAPACITORS ARE IN MICROFARADS, 0603.
 2. INSTALL SHUNTS AS SHOWN.

<p>CUSTOMER NOTICE</p> <p>LINEAR TECHNOLOGY HAS MADE A BEST EFFORT TO DESIGN A CIRCUIT THAT MEETS CUSTOMER-SUPPLIED SPECIFICATIONS; HOWEVER, IT RESAINS THE CUSTOMER'S RESPONSIBILITY TO VERIFY PROPER AND RELIABLE OPERATION IN THE ACTUAL APPLICATION. COMPONENT SUBSTITUTION AND PRINTED CIRCUIT BOARD LAYOUT MAY SIGNIFICANTLY AFFECT CIRCUIT PERFORMANCE OR RELIABILITY. CONTACT LINEAR TECHNOLOGY APPLICATIONS ENGINEERING FOR ASSISTANCE.</p> <p>C:\PADS\PROJECTS\1785A\SCH\1785A_REV2.DSN</p> <p>THIS CIRCUIT IS PROPRIETARY TO LINEAR TECHNOLOGY AND SUPPLIED FOR USE WITH LINEAR TECHNOLOGY PARTS.</p>		<p>APPROVALS</p> <table border="1"> <tr> <td>PCB DES.</td> <td>RB</td> </tr> <tr> <td>APP ENG.</td> <td>LEO C</td> </tr> </table>		PCB DES.	RB	APP ENG.	LEO C	<p>LINEAR TECHNOLOGY</p> <p>1630 McCarthy Blvd. Milpitas, CA 95035 Phone: (408)432-1900 www.linear.com Fax: (408)434-6507 LTC Confidential-For Customer Use Only</p>	
PCB DES.	RB								
APP ENG.	LEO C								
<p>TITLE: SCHEMATIC</p> <p>TEMPERATURE, VOLTAGE AND CURRENT MONITOR</p>									
<p>SIZE: N/A</p>		<p>IC NO.: LTC2991CMS</p>							
<p>SCALE: NONE</p>		<p>REV: 2</p>							
<p>DATE: Monday, April 25, 2011</p>		<p>SHEET 1 OF 1</p>							

DEMO MANUAL DC1785A

DEMONSTRATION BOARD IMPORTANT NOTICE

Linear Technology Corporation (LTC) provides the enclosed product(s) under the following **AS IS** conditions:

This demonstration board (DEMO BOARD) kit being sold or provided by Linear Technology is intended for use for **ENGINEERING DEVELOPMENT OR EVALUATION PURPOSES ONLY** and is not provided by LTC for commercial use. As such, the DEMO BOARD herein may not be complete in terms of required design-, marketing-, and/or manufacturing-related protective considerations, including but not limited to product safety measures typically found in finished commercial goods. As a prototype, this product does not fall within the scope of the European Union directive on electromagnetic compatibility and therefore may or may not meet the technical requirements of the directive, or other regulations.

If this evaluation kit does not meet the specifications recited in the DEMO BOARD manual the kit may be returned within 30 days from the date of delivery for a full refund. **THE FOREGOING WARRANTY IS THE EXCLUSIVE WARRANTY MADE BY THE SELLER TO BUYER AND IS IN LIEU OF ALL OTHER WARRANTIES, EXPRESSED, IMPLIED, OR STATUTORY, INCLUDING ANY WARRANTY OF MERCHANTABILITY OR FITNESS FOR ANY PARTICULAR PURPOSE. EXCEPT TO THE EXTENT OF THIS INDEMNITY, NEITHER PARTY SHALL BE LIABLE TO THE OTHER FOR ANY INDIRECT, SPECIAL, INCIDENTAL, OR CONSEQUENTIAL DAMAGES.**

The user assumes all responsibility and liability for proper and safe handling of the goods. Further, the user releases LTC from all claims arising from the handling or use of the goods. Due to the open construction of the product, it is the user's responsibility to take any and all appropriate precautions with regard to electrostatic discharge. Also be aware that the products herein may not be regulatory compliant or agency certified (FCC, UL, CE, etc.).

No License is granted under any patent right or other intellectual property whatsoever. **LTC assumes no liability for applications assistance, customer product design, software performance, or infringement of patents or any other intellectual property rights of any kind.**

LTC currently services a variety of customers for products around the world, and therefore this transaction **is not exclusive**.

Please read the DEMO BOARD manual prior to handling the product. Persons handling this product must have electronics training and observe good laboratory practice standards. **Common sense is encouraged.**

This notice contains important safety information about temperatures and voltages. For further safety concerns, please contact a LTC application engineer.

Mailing Address:

Linear Technology
1630 McCarthy Blvd.
Milpitas, CA 95035

Copyright © 2004, Linear Technology Corporation