



Chipsmall Limited consists of a professional team with an average of over 10 year of expertise in the distribution of electronic components. Based in Hongkong, we have already established firm and mutual-benefit business relationships with customers from,Europe,America and south Asia,supplying obsolete and hard-to-find components to meet their specific needs.

With the principle of “Quality Parts,Customers Priority,Honest Operation,and Considerate Service”,our business mainly focus on the distribution of electronic components. Line cards we deal with include Microchip,ALPS,ROHM,Xilinx,Pulse,ON,Everlight and Freescale. Main products comprise IC,Modules,Potentiometer,IC Socket,Relay,Connector.Our parts cover such applications as commercial,industrial, and automotives areas.

We are looking forward to setting up business relationship with you and hope to provide you with the best service and solution. Let us make a better world for our industry!



Contact us

Tel: +86-755-8981 8866 Fax: +86-755-8427 6832

Email & Skype: info@chipsmall.com Web: www.chipsmall.com

Address: A1208, Overseas Decoration Building, #122 Zhenhua RD., Futian, Shenzhen, China



LTC3245EMSE

Wide V_{IN} Range, Low Noise 250mA Buck-Boost Charge Pump

DESCRIPTION

Demonstration circuit DC1802A is a wide V_{IN} range, low noise, 250mA buck-boost charge pump featuring the LTC[®]3245EMSE.

Design files for this circuit board are available at <http://www.linear.com/demo>

LT, LTC, LTM, Linear Technology, the Linear logo and Burst Mode are registered trademarks of Linear Technology Corporation. All other trademarks are the property of their respective owners.

PERFORMANCE SUMMARY Specifications are at $T_A = 25^\circ\text{C}$

SYMBOL	PARAMETER	CONDITIONS	MIN	TYP	MAX	UNITS
V_{IN}	Input Voltage Range		2.7		38	V
V_{OUT1}	Output Voltage	SEL2 = HIGH, SEL1 = LOW	4.80		5.20	V
V_{OUT2}	Output Voltage	SEL2 = HIGH, SEL1 = HIGH	3.168		3.432	V
V_{FB}	Feedback Voltage	SEL2 = LOW SEL1 = HIGH	1.176	1.200	1.224	V
I_{VOUT}	Output Current	$V_{IN} > 5\text{V}$, $V_{OUT} \pm 4\%$, Burst Mode [®] Operation $V_{IN} > 5\text{V}$, $V_{OUT} \pm 4\%$, Low Noise Mode			250 200	mA mA

ASSEMBLY TEST PROCEDURE

Refer to Figure 1 for the proper measurement equipment setup and jumper settings and follow the procedure below.

Note: When measuring the input or output voltage ripple, care must be taken to avoid a long ground lead on the oscilloscope probe. Measure the input or output voltage ripple by touching the probe tip directly across the VBUS or VOUT(x) and GND terminals. See Figure 2 for proper scope probe technique.

1. Set PS1 = 13V, LD1 = 0A, SEL2 = HIGH, and SEL1 = HIGH. Observe VOUT (VM2).
2. Set LD1 = 250mA. Observe VOUT (VM2).
3. Set SEL1 = LOW, LD1 = 0A. Observe VOUT (VM2).
4. Set LD1 to 250mA. Observe VOUT (VM2).
5. The value of V_{OUT} can be programmed to any desired value by populating R1 and R2.

ASSEMBLY TEST PROCEDURE

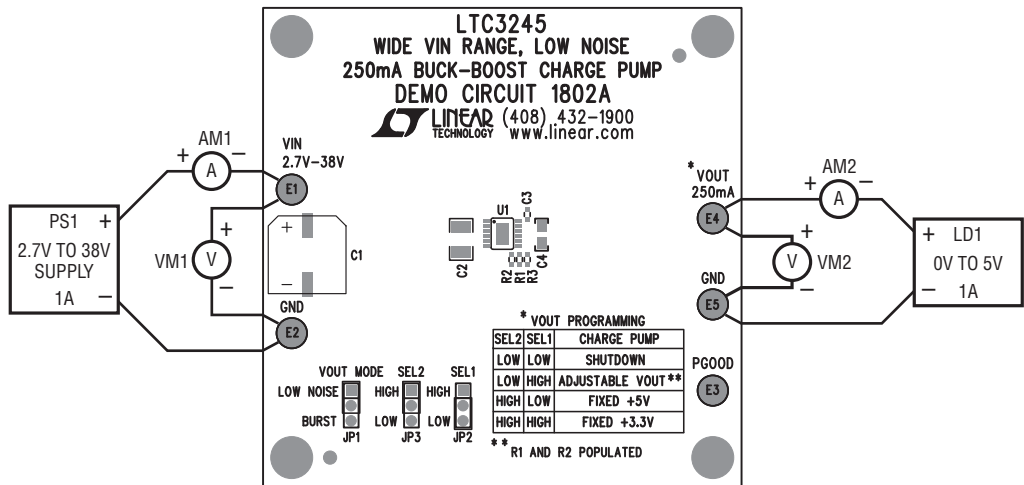

Figure 1. Proper Measurement Equipment Setup for DC1802A

Note: All connections from equipment should be Kelvin connected directly to the board pins which they are connected on this diagram and any input or output leads should be twisted pair.

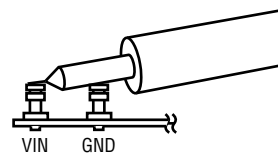

Figure 2. Measuring Input or Output Ripple

ASSEMBLY TEST PROCEDURE

Figures 3 and 4 are CISPR25 radiated and conducted emissions respectively. The data were collected in a GTEM chamber and using a CISPR25 LISN for conducted emissions.

Linear Technology has made every effort to provide useful and accurate EMI data, but it remains the responsibility of the customer to ensure product compliance with applicable rules and regulations.

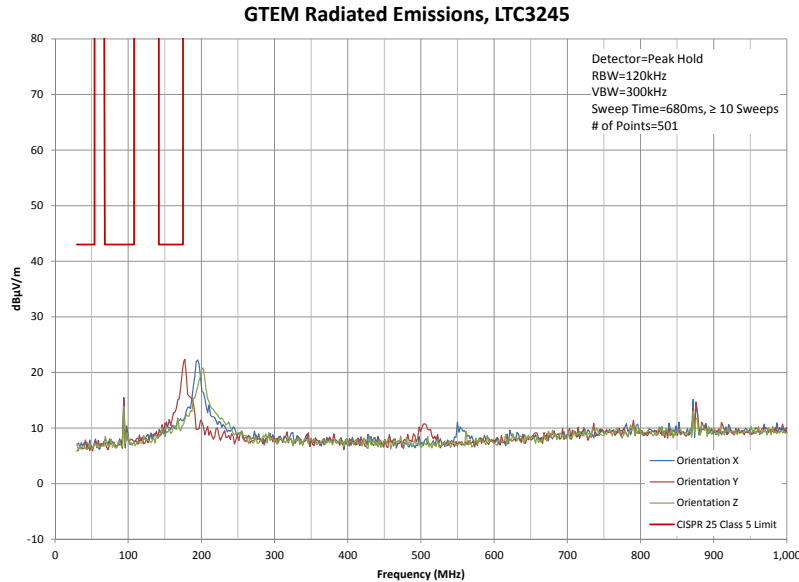

Figure 3. CISPR25 Radiated Emissions

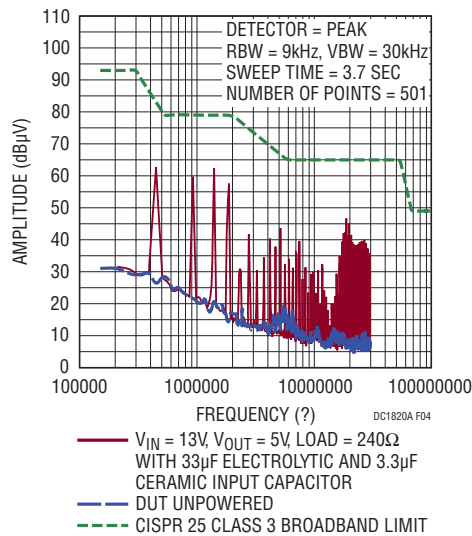

Figure 4. CISPR25 Conducted Emissions

DEMO MANUAL DC1802A

PARTS LIST

ITEM	QTY	REFERENCE	PART DESCRIPTION	MANUFACTURE / PART #
Required Circuit Components				
1	0	C1-OPT	CAP, ELECTROLYTIC, 33 μ F, \pm 20%, 63V, 10mmX10.5mm	SUNCON, 63HVH33M
2	1	C2	CAP, CHIP, X7R, 3.3 μ F, \pm 10%, 50V, 1210	TDK, C3225X7R1H335K
3	1	C3	CAP, CHIP, X5R, 1 μ F, \pm 10%, 10V, 0402	TDK, C1005X5R1A105K
4	1	C4	CAP, CHIP, X5R, 47 μ F, \pm 20%, 6.3V, 0805	SAMSUNG, CL21A476MQYNNNB
4	0	C5-OPT	CAP, CHIP, X5R, 100 μ F, \pm 20%, 6.3V, 1206	MURATA, GRM31CR60J107ME39L
5	1	R1	RES, CHIP, 0 Ω JUMPER, 1/16W, 0402	VISHAY, CRCW04020000Z0ED
6	1	U1	IC, SMT, WIDE VIN RANGE, LOW NOISE 250mA BUCK-BOOST CHARGE PUMP	LINEAR TECH., LTC3245EMSE
Additional Demo Board Circuit Components				
1	0	R2-OPT	RES, CHIP, \pm 1%, 1/16W, 0402	USER SUPPLIED
2	1	R3	RES, CHIP, 470k, \pm 5%, 1/16W, 0402	VISHAY, CRCW0402470KJNED
Hardware For Demo Board Only				
1	4	E1-E2, E4-E5	TURRET, 0.09 DIA	MILL-MAX, 2501-2-00-80-00-00-07-0
2	1	E3	TURRET, 0.061 DIA	MILL-MAX, 2308-2-00-80-00-00-07-0
3	3	JP1 JP3	3-Pin JUMPER, 2mm	SAMTEC, TMM-103-02-L-S
4	3	XJP1-XJP3	SHUNT, 2mm	SAMTEC, 2SN-KB-G
5	4		STAND-OFF, NYLON, 0.375"	KEYSTONE, 8832

SCHEMATIC DIAGRAM

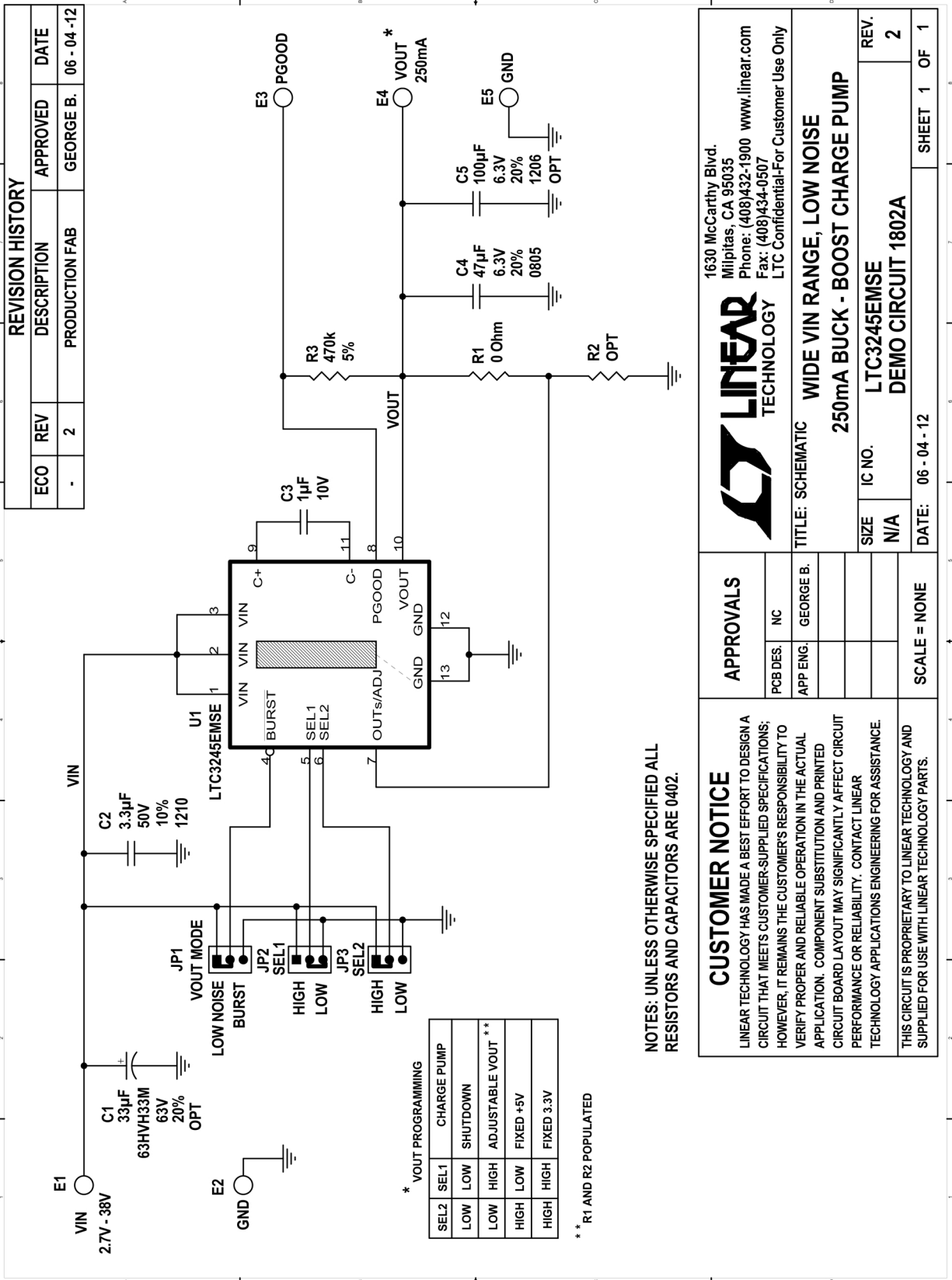

1630 McCarthy Blvd.
Milpitas, CA 95035
Phone: (408)432-1900 www.linear.com
Fax: (408)434-0507
LTC Confidential-For Customer Use Only

TITLE: SCHEMATIC
250mA BUCK - BOOST CHARGE PUMP

SIZE	IC NO.	REV.
N/A	LTC3245EMSE	2

DATE: 06 - 04 - 12 SHEET 1 OF 1

CUSTOMER NOTICE

LINEAR TECHNOLOGY HAS MADE A BEST EFFORT TO DESIGN A CIRCUIT THAT MEETS CUSTOMER-SUPPLIED SPECIFICATIONS; HOWEVER, IT REMAINS THE CUSTOMER'S RESPONSIBILITY TO VERIFY PROPER AND RELIABLE OPERATION IN THE ACTUAL APPLICATION. COMPONENT SUBSTITUTION AND PRINTED CIRCUIT BOARD LAYOUT MAY SIGNIFICANTLY AFFECT CIRCUIT PERFORMANCE OR RELIABILITY. CONTACT LINEAR TECHNOLOGY APPLICATIONS ENGINEERING FOR ASSISTANCE.

THIS CIRCUIT IS PROPRIETARY TO LINEAR TECHNOLOGY AND SUPPLIED FOR USE WITH LINEAR TECHNOLOGY PARTS.

APPROVALS

PCB DES.	NC
APP ENG.	GEORGE B.
SCALE = NONE	

DEMO MANUAL DC1802A

DEMONSTRATION BOARD IMPORTANT NOTICE

Linear Technology Corporation (LTC) provides the enclosed product(s) under the following **AS IS** conditions:

This demonstration board (DEMO BOARD) kit being sold or provided by Linear Technology is intended for use for **ENGINEERING DEVELOPMENT OR EVALUATION PURPOSES ONLY** and is not provided by LTC for commercial use. As such, the DEMO BOARD herein may not be complete in terms of required design-, marketing-, and/or manufacturing-related protective considerations, including but not limited to product safety measures typically found in finished commercial goods. As a prototype, this product does not fall within the scope of the European Union directive on electromagnetic compatibility and therefore may or may not meet the technical requirements of the directive, or other regulations.

If this evaluation kit does not meet the specifications recited in the DEMO BOARD manual the kit may be returned within 30 days from the date of delivery for a full refund. **THE FOREGOING WARRANTY IS THE EXCLUSIVE WARRANTY MADE BY THE SELLER TO BUYER AND IS IN LIEU OF ALL OTHER WARRANTIES, EXPRESSED, IMPLIED, OR STATUTORY, INCLUDING ANY WARRANTY OF MERCHANTABILITY OR FITNESS FOR ANY PARTICULAR PURPOSE. EXCEPT TO THE EXTENT OF THIS INDEMNITY, NEITHER PARTY SHALL BE LIABLE TO THE OTHER FOR ANY INDIRECT, SPECIAL, INCIDENTAL, OR CONSEQUENTIAL DAMAGES.**

The user assumes all responsibility and liability for proper and safe handling of the goods. Further, the user releases LTC from all claims arising from the handling or use of the goods. Due to the open construction of the product, it is the user's responsibility to take any and all appropriate precautions with regard to electrostatic discharge. Also be aware that the products herein may not be regulatory compliant or agency certified (FCC, UL, CE, etc.).

No License is granted under any patent right or other intellectual property whatsoever. **LTC assumes no liability for applications assistance, customer product design, software performance, or infringement of patents or any other intellectual property rights of any kind.**

LTC currently services a variety of customers for products around the world, and therefore this transaction **is not exclusive**.

Please read the DEMO BOARD manual prior to handling the product. Persons handling this product must have electronics training and observe good laboratory practice standards. **Common sense is encouraged.**

This notice contains important safety information about temperatures and voltages. For further safety concerns, please contact a LTC application engineer.

Mailing Address:

Linear Technology
1630 McCarthy Blvd.
Milpitas, CA 95035

Copyright © 2004, Linear Technology Corporation