



Chipsmall Limited consists of a professional team with an average of over 10 year of expertise in the distribution of electronic components. Based in Hongkong, we have already established firm and mutual-benefit business relationships with customers from,Europe,America and south Asia,supplying obsolete and hard-to-find components to meet their specific needs.

With the principle of “Quality Parts,Customers Priority,Honest Operation,and Considerate Service”,our business mainly focus on the distribution of electronic components. Line cards we deal with include Microchip,ALPS,ROHM,Xilinx,Pulse,ON,Everlight and Freescale. Main products comprise IC,Modules,Potentiometer,IC Socket,Relay,Connector.Our parts cover such applications as commercial,industrial, and automotives areas.

We are looking forward to setting up business relationship with you and hope to provide you with the best service and solution. Let us make a better world for our industry!



Contact us

Tel: +86-755-8981 8866 Fax: +86-755-8427 6832

Email & Skype: info@chipsmall.com Web: www.chipsmall.com

Address: A1208, Overseas Decoration Building, #122 Zhenhua RD., Futian, Shenzhen, China



Multicell Battery Gas Gauge with Temperature, Voltage and Current Measurement

DESCRIPTION

Demonstration circuit 1812A-A (Figure 1) features the [LTC[®]2943](#). Demonstration circuit 1812A-B features the [LTC2944](#). Demonstration circuit 1812A-C features the [LTC2943-1](#). The LTC2943/LTC2943-1 has an operating range of 3.6V to 20V, while the LTC2944 has an operating range of 3.6V to 60V, making all three devices perfectly suited for multicell battery applications. A precision analog coulomb counter integrates current measured through a sense resistor between the battery's positive terminal and the load or charger. The LTC2943/LTC2943-1 measures voltage, current and temperature with an internal 14-bit No Latency $\Delta\Sigma$ ADC. The LTC2944 measures voltage, current and temperature with an internal 16-bit No Latency $\Delta\Sigma$ ADC. The measurements are stored in internal registers accessible via the onboard SMBus/I²C interface.

The LTC2943/LTC2943-1/LTC2944 has programmable high and low thresholds for all measured quantities. If a programmed threshold is exceeded, the device reports an alert using either the SMBus alert protocol or by setting a flag in the internal status register.

The LTC2943 and LTC2944 require only a single low value sense resistor to set the measured current range.

The LTC2943-1, however, has an integrated sense resistor of 50m Ω which sets the maximum current measurement to 1A. The default value assembled on the DC1812A-A and DC1812A-B is 100m Ω for a maximum current measurement of 500mA. The DC1812A-C which showcases the LTC2943-1 has the onboard sense resistor omitted in favor of the integrated 50m Ω sense resistor. All three parts have a software-configurable charge complete/alert pin. When the pin is set for charge complete, a jumper connects the pushbutton which simulates a logic low input at the $\overline{\text{AL/CC}}$ pin. This sets the ACR register to FFFFh which indicates a full battery. When the pin is configured for alert, the same jumper is used to connect a red LED that indicates an alert is present.

The DC1812A is a part of the QuikEval[™] system for quick evaluation with a host controller through a PC using the DC590 or DC2026.

Design files for this circuit board are available at <http://www.linear.com/demo/DC1812A>

LT, LT, LTC, LTM, Linear Technology and the Linear logo are registered trademarks and No Latency $\Delta\Sigma$ and QuikEval are trademarks of Linear Technology Corporation. All other trademarks are the property of their respective owners.

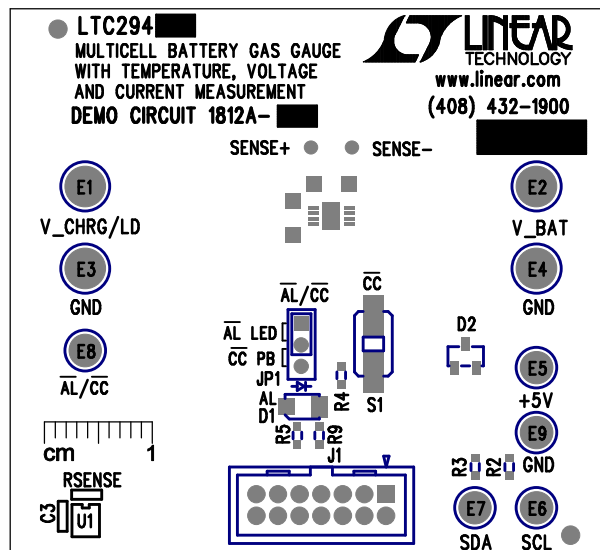

Figure 1. DC1812A

QUICK START PROCEDURE

Demonstration circuit 1812A is easy to set up to evaluate the performance of the LTC2943/LTC2943-1/LTC2944. Refer to Figure 2 for proper measurement equipment setup and follow the procedure below.

1. Connect a Li-Ion battery across V_BAT and GND. Multiple Li-Ion batteries can also be used as long as the total voltage does not exceed the operating voltage of the device. The LTC2943/LTC2943-1 has a maximum operating voltage of 20V, so for a 4.2V lithium ion battery the maximum cell count would be 4 cells. The LTC2944 has a maximum operating voltage of 60V, so for a 4.2V lithium-ion battery the maximum cell count would be 14 cells.
2. Connect a load across V_CHRG/LD and GND for battery discharge measurement.
3. Connect 3.6V to 20V (LTC2943/LTC2943-1) or 3.6V to 60V (LTC2944) battery charger supply across V_CHRG/LD and GND for battery charge measurement. Up to 500mA supplied to the battery can be measured with the board default 100mΩ sense resistor.
4. Connect a DC590 to 14-pin connector J1 for evaluation with QuikEval, or connect a host controller I²C bus to the SDA, SCL and GND test turrets.
5. If a host I²C controller is used, then provide a bus pull-up voltage to the +5V turret, else start QuikEval software on PC.
6. Read and write to the LTC2943/LTC2943-1/LTC2944 through I²C.
7. Through I²C, configure the $\overline{AL/CC}$ pin. Set JP1 accordingly.
8. If $\overline{AL/CC}$ is set for charge complete, use pushbutton switch S1 to simulate a logic low from a controller to indicate a fully charged battery.

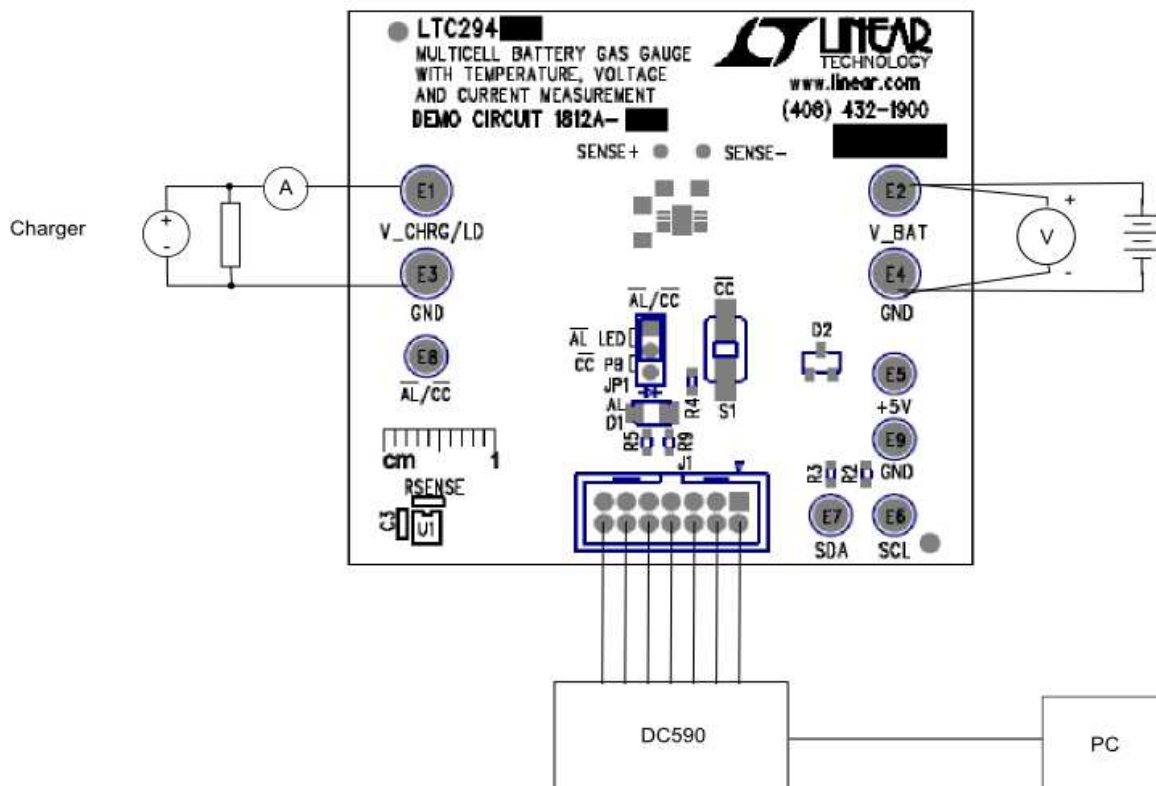

Figure 2. DC1812A Basic Setup

QUIKEVAL INTERFACE

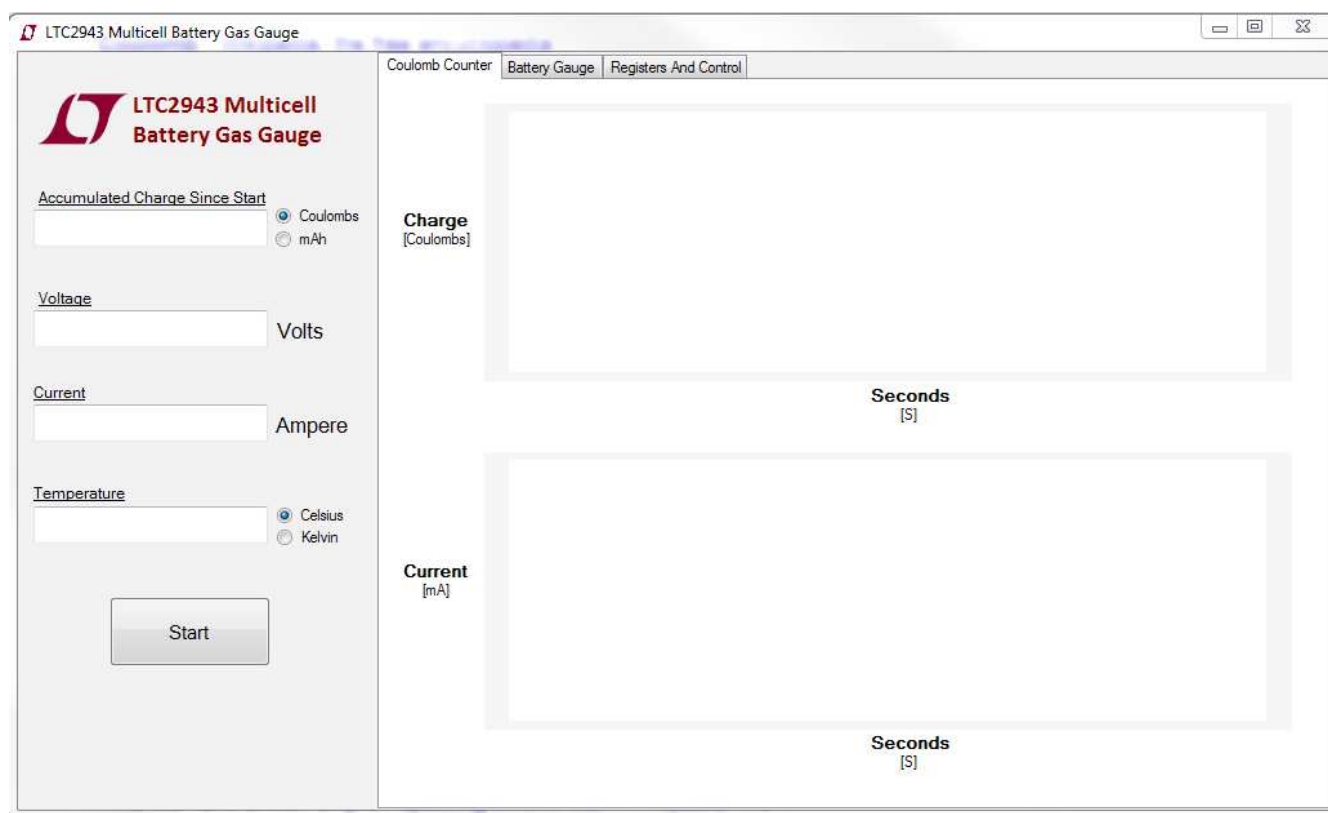

Figure 3. DC1812A QuikEval Interface

The DC1812A can be connected to a DC590 and used with the QuikEval software. The DC590 connects to a PC through USB. QuikEval automatically detects the demo board and brings up the LTC2943/LTC2944 evaluation software interface (Figure 3).

Interface Design

The QuikEval interface consists of three tabs along with a column that displays accumulated charge since the start of the scan, voltage, current and temperature. A start button allows convenient polling of the registers.

INFO COLUMN

Accumulated Charge Since Start (ACR Display)

The “Accumulated Charge Since Start” text box displays the change in accumulated charge since the start of a scan. The initial data in the ACR registers (registers C and D)

is first stored at the start of a scan and then any change in charge is reported in the ACR text box. This data can be displayed in one of two formats: coulombs and mAh.

Voltage and Current Display

Data from the voltage ADC (registers I and J) and the current ADC (registers O and P) is displayed here in volts and amperes, respectively. If the current falls into the mA range then the interface automatically updates the units accordingly. The display indicates the current as seen from the battery. Hence, if a negative value is displayed, the battery is discharging. If a positive value is displayed, the battery is charging.

Temperature Display

Data from the temperature ADC (register U and V) is displayed here. It can be displayed in two formats: Celsius and Kelvin.

QUIKEVAL INTERFACE

Start Button

Click on start to begin a polling routine that is based on the selected ADC mode. By default the ADC mode is set to automatic mode which updates the interface every 60ms. If the scan ADC mode is selected from the “Registers and Control” tab, then the interface would update every 10s. The ADC mode can be switched in real time during a scan and the interface will respond accordingly.

The interface recognizes when it is scanning and replaces the start button with a stop button during a polling routine. Similarly, for a single update, select the manual mode and click start. The LTC2943/LTC2943-1/LTC2944 will take a snapshot of the charge, voltage, current and temperature after which it will immediately go into sleep mode in which

only the charge accumulator is running. For convenience the GUI will hold the values of the snapshot for 2 seconds before updating the interface and displaying “ADC Off” in the current, voltage and temperature text box.

COULOMB COUNTER TAB

This tab contains time based graphical plots of charge and current. The charge plot displays the change in accumulated charge since the start of a scan with respect to time in mAh or coulombs depending on user input. The current plot displays the change in current with respect to time in mA. If the current exceeds 1A, then the graph auto scales to display the current in units of amperes. If a scan is restarted, the plots start from the beginning. If manual mode is selected, only the charge plot is active.

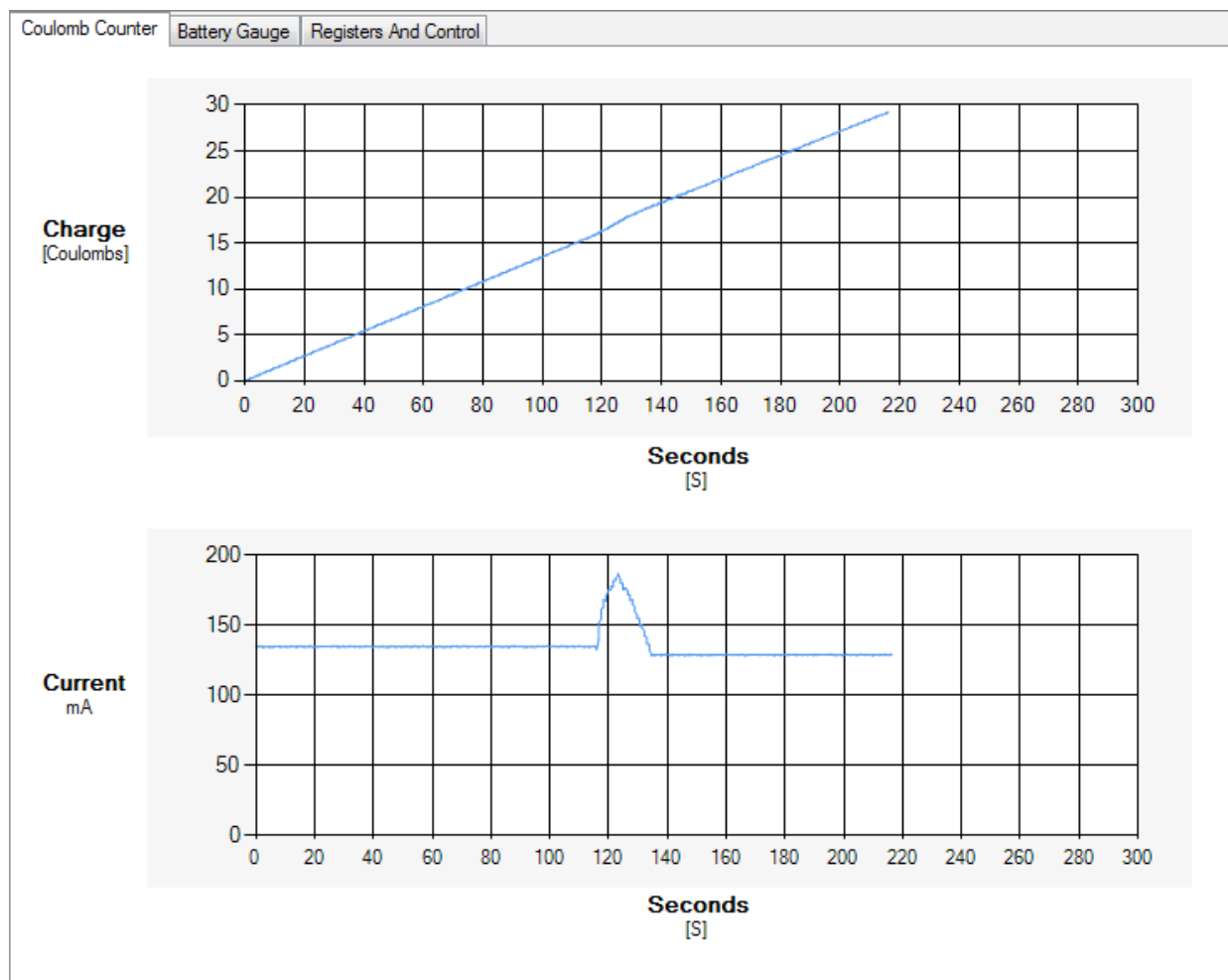

Figure 4. Coulomb Counter Tab

QUIKEVAL INTERFACE

Once the plotted line reaches 300, the x-axis scrolls to accommodate by 30 second intervals.

BATTERY GAUGE TAB

This tab contains controls to set up the battery gas gauge and consists of two sections: User Input and Initialization.

User Input

For applications that have low current and a large battery, it is possible to get a q_{LSB} size smaller than $Q_{BAT}/2^{16}$, causing the 16-bit accumulated charge register to underflow before the battery is exhausted or overflow during charge.

In such cases, R_{SENSE} should be sized according to the following relationship:

$$R_{SENSE} \leq \frac{0.340\text{mAh} \cdot 2^{16}}{Q_{BAT}} \cdot 50\text{m}\Omega$$

where Q_{BAT} is in mAh. Similarly, for applications with a small battery but high maximum current the q_{LSB} can get quite large with respect to the battery capacity causing a loss in digital resolution in the accumulated charge register. To address this, the LTC2943/LTC2943-1/LTC2944 includes a programmable prescaler. Lowering the prescaler factor M reduces q_{LSB} to better match the accumulated charge

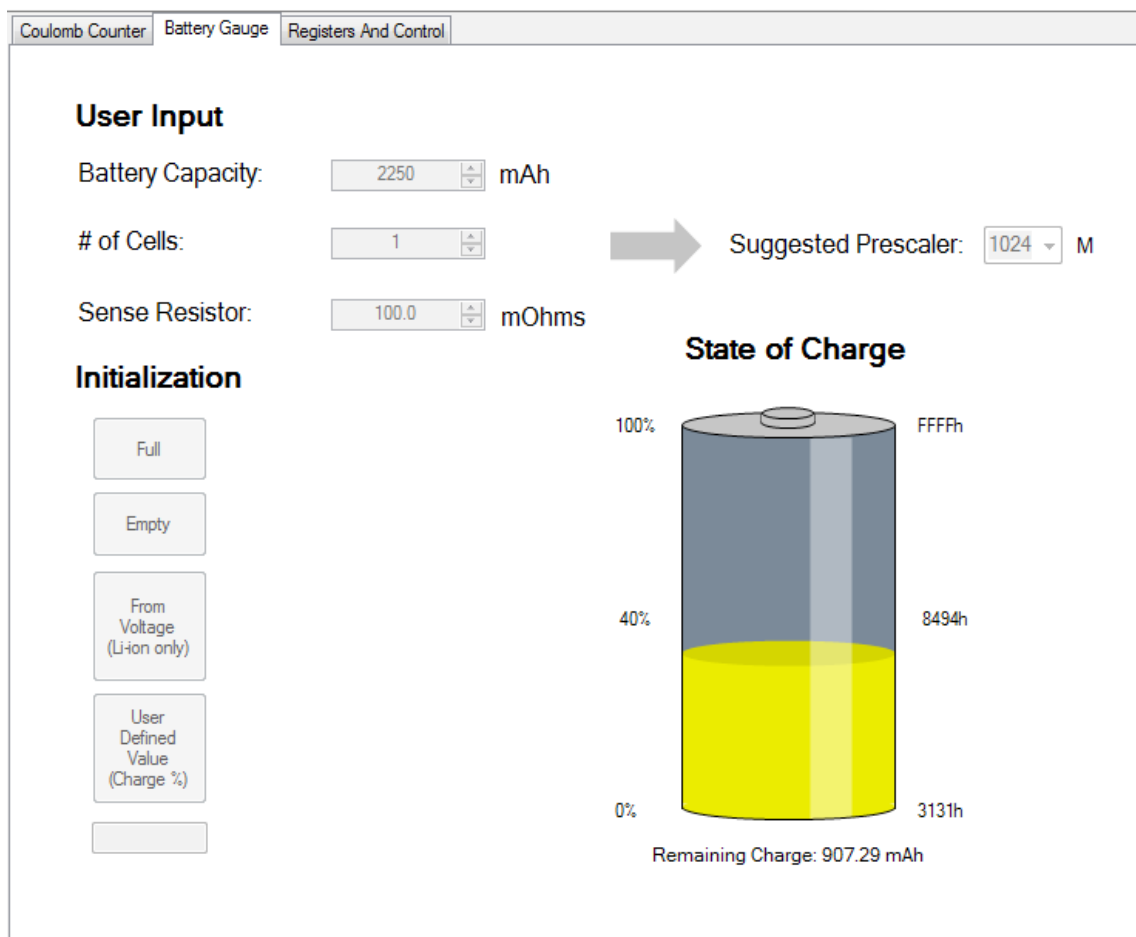

Figure 5. Battery Gauge Tab

QUIKEVAL INTERFACE

register to the capacity of the battery. M can be chosen between 1 and its default value of 4096. The charge LSB then becomes:

$$q_{LSB} = 0.34\text{mAh} \cdot \frac{50\text{m}\Omega}{R_{SENSE}} \cdot \frac{M}{4096}$$

To avoid unnecessary calculation, the interface conveniently suggests a prescalar value to use based on the entered battery capacity and sense resistor value. This prescalar can be overridden by the user with the help of the prescalar dropdown box. In the case of an override, the prescalar dropdown box will be colored red giving a visual cue that the prescalar chosen is not the suggested one.

The interface also warns the user in case the current is too small with respect to the battery capacity by giving an error message similar to the one shown in Figure 6.

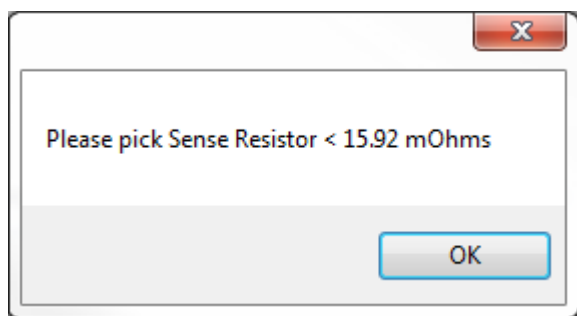

Figure 6. Low Current Warning

Initializing the Accumulated Charge Register

By default, the ACR register has the initial value of 0x7FFF. The ACR register can be initialized to full, empty or set to a user defined level based on battery capacity.

The “From Voltage (Li-ion Only)” button gives an estimate of the initial ACR value by sensing the voltage and ambient temperature of the battery being used. It compares the voltage and temperature values to the discharge curves of a Panasonic CGR18650CG lithium ion battery to estimate the battery’s state of charge. Due to the fact that the discharge curve for each lithium ion battery is different, the state of charge calculated this way might not be accurate.

It is strongly advised to use a characterized battery whose state of charge is already known and to initialize the ACR value accordingly.

Battery Gas Gauge

The gas gauge shows the battery’s state of charge. The upper battery limit is always 0xFFFF while the lower limit is dependent on the battery capacity and q_{LSB} size. This lower limit is calculated based off of R_{SENSE} and prescalar M, and displayed in hexadecimal in the lower right corner of the gas gauge. Battery charge percentage as well as the ACR register value is shown alongside the gas gauge. The amount of charge left is also represented in mAh under the battery widget.

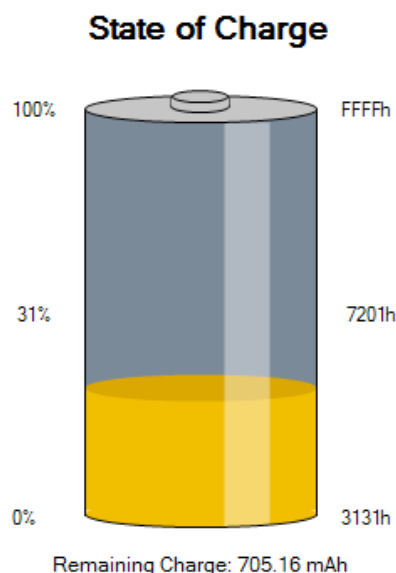

Figure 7. Battery Gas Gauge

QUIKEVAL INTERFACE

REGISTER AND CONTROL TAB

The register and control tab provides a detailed view of the LTC2943/LTC2943-1/LTC2944 device registers as well as provides convenient means to read and write to them.

Address/I²C Status

The write address for the LTC2943/LTC2943-1/LTC2944 is C8h and the read address is C9h. If an error occurs while reading from the LTC2943/LTC2943-1/LTC2944, the I²C status will display an error and the corresponding LED will turn red. Otherwise, the status is good and the LED remains green.

Sense Resistor

By default, the DC1812A-A and DC1812A-B are populated with a 100mΩ sense resistor to measure a maximum full-scale current of 500mA. If a different full-scale value current is desired, the sense resistor can be easily replaced and the corresponding resistor value can be set in the interface. Every time a new resistor value is entered, the interface will recalculate a suggested prescaler and q_{LSB} automatically and display it in the “LSB Information” section.

The screenshot shows the 'Registers And Control' tab of the QUIKEVAL interface. It is organized into several functional areas:

- Address/I²C Status:** Shows Write Address: C8h, Read Address: C9h, and ARA Address: 19h. The I2C Status is 'Good!' with a green LED indicator.
- Sense Resistor:** A text input field for 'R Sense (mOhm)' is set to 100.0.
- Status Register (A):** A list of status bits with radio buttons: A[7] Reserved, A[6] Current Alert, A[5] ACR Overflow/Underflow, A[4] Temperature Alert, A[3] Charge Alert High, A[2] Charge Alert Low, A[1] Voltage Alert, and A[0] Undervoltage Lockout Alert. A 'Demo Board Alert Pin' is also shown with an 'ARA' button.
- Control Register (B):** Includes 'ADC Mode' with radio buttons for [11] Automatic Mode (Default), [10] Scan Mode, [01] Manual Mode, and [00] Sleep Mode. A 'Pre Scaler M' dropdown is set to 1024. The 'AL#/CC Configure' section has radio buttons for [11] Not Allowed, [10] Alert Mode (selected), [01] Charge Complete Mode, and [00] AL#/CC# pin disabled. A 'Shutdown analog section' checkbox is present.
- LSB Information:** Displays calculated values: ACR and Threshold LSB: 4.25E-005Ah, Voltage and Threshold LSB: 360μV, Current and Threshold LSB: 2.93E-004A, Temperature LSB: 0.24°K, and Temperature Threshold LSB: 1.96°K.
- Register Read/Write:** A table for reading and writing to registers. The 'Hex' radio button is selected. The table lists registers B through X with their data values and buttons to 'Send To' (Control, ACR, Chrg Thr HI, Chrg Thr LO, Volt Thr HI, Volt Thr LO, Cur Thr HI, Cur Thr LO, Temp Thr HI, Temp Thr LO).

Figure 8. Register and Control Tab

QUIKEVAL INTERFACE

LSB Information

LSB information for charge, voltage, current and temperature registers as well as for all threshold registers is displayed here. The ACR LSB updates depending on the sense resistor and prescalar value chosen.

Status Register (A)

The individual status bits A[0:7] and their states are shown here. A red indicator next to bits A[6:0] indicates the respective alert is currently present and will latch the alert pin if configured for alert. Bit A[7] is reserved.

The demo board alert pin indicator indicates the status of the $\overline{AL/CC}$ pin. If the LTC2943/LTC2943-1/LTC2944 $\overline{AL/CC}$ pin is set for alert mode and an alert has been latched, the device will pull down this pin which will light up the LED indicator on the board as well as on the GUI. Click on ARA to send out an SMBus alert on to the bus lines and the device will respond with its address. The LED indicator on the demo board and GUI alert pin indicator will then be cleared if the alert is no longer present.

Control Register (B)

Configurations done in the control register section write to the control register (register B). The control bits B[7:6] set the LTC2943/LTC2943-1/LTC2944 ADC mode. The LTC2943/LTC2943-1/LTC2944 defaults to automatic mode which enables full-time voltage, current and temperature ADC conversions. Selecting scan mode enables voltage, current and temperature conversions cycles every 10s. After each conversion cycle the ADC goes into sleep mode until it is time for the next conversion cycle. Selecting manual mode initiates the ADC for a snapshot of voltage, temperature, current and charge once after which it returns to sleep mode. In sleep mode, the LTC2943/LTC2943-1/LTC2944 continues to accumulate charge while the ADC turns off.

Select a prescalar M value to scale the ACR according to battery capacity and maximum current. M cannot be changed during a scan.

The $\overline{AL/CC}$ pin can be configured for alert mode, charge complete mode, or disabled. Select the corresponding settings on the DC1812 jumper JP1.

The shutdown analog section is checked to disable the analog portion of the LTC2943/LTC2943-1/LTC2944 and set the device in a low current state. For normal operation leave unchecked.

Register Read/Write

Data in the internal registers of the LTC2943/LTC2943-1/LTC2944 is displayed here in hexadecimal format. Data can also be entered and written to the write registers. Enter data to be written in hexadecimal, or select unit and enter data in decimal form. Then click on the corresponding register button to write to that register. Data is auto corrected if the maximum or minimum full-scale is exceeded.

Interfacing with the DC2062B

This board can also interface with the DC2026 Linduino board which is part of the Linduino Firmware Development Program. The Linduino Firmware Development Program provides users with convenient driver code, written in C, for a wide range of LTC products. Please see the Linduino page for more details.

The DC2026 comes preloaded with a DC590 emulator firmware which allows easy interface with QuikEval. With the emulator firmware, QuikEval will launch the GUI as it would with the DC590. The DC2026 can also be used as a development platform, example software along with drivers can be found on the relevant product landing page:

LTC2943: <http://www.linear.com/LTC2943>

LTC2943-1: <http://www.linear.com/LTC2943-1>

LTC2944: <http://www.linear.com/LTC2944>

PARTS LIST

ITEM	QTY	REFERENCE	PART DESCRIPTION	MANUFACTURER/PART NUMBER
1	1	C2	CAP., CHIP X7R, 0.1 μ F 0603	AVX, 06033C104KAT2A
2	1	C3	CAP., X7R, 1.0 μ F, 100V, 10%, 1206	MURATA, GRM31CR72A105KA01
3	1	D1	WL-SMCW SMD CHIP LED WATERCLEAR	WURTH, 150120RS75000
4	1	D2	DIODE, BAT54C SOT23	DIODES INC., BAT54C-7-F
5	4	E1-E4	TURRET, TESTPOINT .094"	MILL-MAX, 2501-2-00-80-00-00-07-0
6	5	E5-E9	TURRET, TESTPOINT .064"	MILL-MAX, 2308-2-00-80-00-00-07-0
7	1	JP1	HEADER, 3 PIN 1 ROW .079CC	WURTH, 62000311121
8	1	XJP1	SHUNT, .079" CENTER	WURTH, 60800213421
9	1	J1	HEADERS, VERTICAL DUAL 2x7 .079CC	MOLEX, 87831-1420
10	3	R6, R7, R8	RES., CHIP, 4.99k, 1%, 0603	NIC, NRC06F4991TRF
11	4	R2, R3, R4, R9	RES., CHIP, 10k, 5%, 0603	NIC, NRC06J103TRF
12	1	R5	RES., CHIP, 1k, 5%, 0603	VISHAY, CRCW06031K00JNEA
13	1	S1	SWITCH, SMT PUSH BUTTON	PANASONIC, EVQPE105K
14	1	U2	I.C., SERIAL EEPROM TSSOP8	MICROCHIP, 24LC025-I/ST

DC1812A-A

1	1		DC1812A GENERAL BOM	
2	1	R _{SENSE}	RES., CHIP, 0.1 Ω 1/8W 1% 1206	IRC, LRC-LR1206LF-01-R100-F
3	1	U1	I.C., BATTERY GAS GAUGE WITH I ² C	LINEAR TECH., LTC2943CDD#PBF

DC1812A-B

1	1		DC1812A GENERAL BOM	
2	1	R _{SENSE}	RES., CHIP, 0.1 Ω 1/8W 1% 1206	IRC, LRC-LR1206LF-01-R100-F
3	1	U1	I.C., BATTERY GAS GAUGE WITH I ² C	LINEAR TECH., LTC2944CDD#PBF

DC1812A-C

1	1		DC1812A GENERAL BOM	
3	1	U1	I.C., BATTERY GAS GAUGE WITH I ² C	LINEAR TECH., LTC2943CDD-1#PBF

SCHEMATIC DIAGRAM

REVISION HISTORY				
ECO	REV	DESCRIPTION	APPROVED	DATE
-	3	PRODUCTION	S. AFZAL	8-10-15

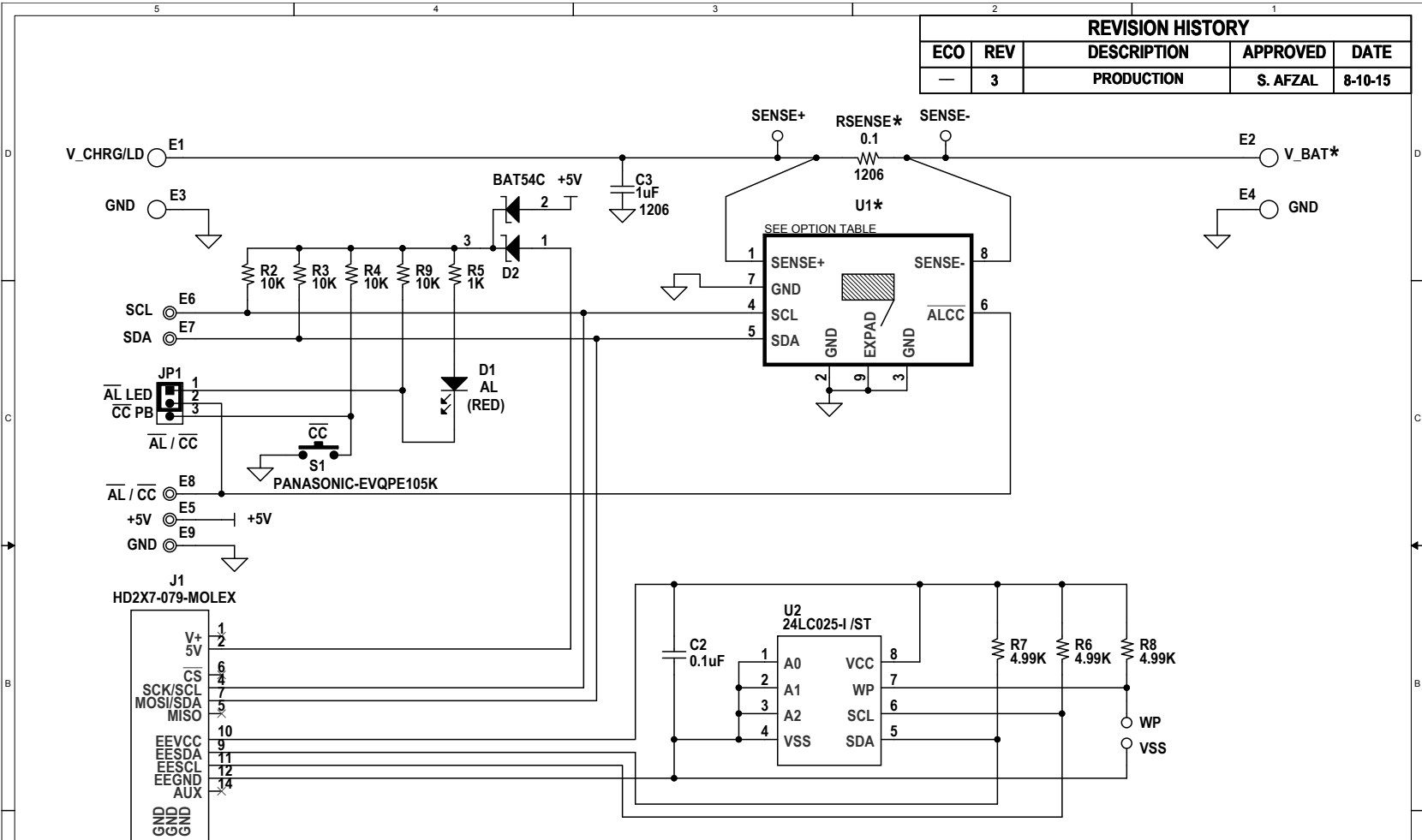

ASSEMBLY	U1	SUFFIX	V-BAT	RSENSE
-A	LTC2943	3	3.6V-20V	0.1
-B	LTC2944	4	3.6V-60V	0.1
-C	LTC2943-1	3-1	3.6V-20V	N/A

NOTE: UNLESS OTHERWISE SPECIFIED
 1. ALL RESISTORS AND CAPACITORS ARE 0603

CUSTOMER NOTICE
 LINEAR TECHNOLOGY HAS MADE A BEST EFFORT TO DESIGN A CIRCUIT THAT MEETS CUSTOMER-SUPPLIED SPECIFICATIONS; HOWEVER, IT REMAINS THE CUSTOMER'S RESPONSIBILITY TO VERIFY PROPER AND RELIABLE OPERATION IN THE ACTUAL APPLICATION. COMPONENT SUBSTITUTION AND PRINTED CIRCUIT BOARD LAYOUT MAY SIGNIFICANTLY AFFECT CIRCUIT PERFORMANCE OR RELIABILITY. CONTACT LINEAR TECHNOLOGY APPLICATIONS ENGINEERING FOR ASSISTANCE.

APPROVALS

PCB DES.	LT
APP ENG.	S. AFZAL

THIS CIRCUIT IS PROPRIETARY TO LINEAR TECHNOLOGY AND SUPPLIED FOR USE WITH LINEAR TECHNOLOGY PARTS.

SCALE = NONE

LINEAR TECHNOLOGY
 1630 McCarthy Blvd.
 Milpitas, CA 95035
 Phone: (408)432-1900 www.linear.com
 Fax: (408)434-0507
 LTC Confidential-For Customer Use Only

TITLE: SCHEMATIC
MULTICELL BATTERY GAS GAUGE WITH TEMPERATURE, VOLTAGE AND CURRENT MEASUREMENT

SIZE N/A IC NO. LTC294XCDD
DEMO CIRCUIT 1812A

DATE: Monday, August 10, 2015

REV. 3 SHEET 1 OF 1

SCHEMATIC DIAGRAM

REVISION HISTORY				
ECO	REV	DESCRIPTION	APP. ENG.	DATE
-	3	PRODUCTION	S. AFZAL	8-10-15

NOTES: UNLESS OTHERWISE SPECIFIED

1. WORKMANSHIP SHALL BE IN ACCORDANCE WITH IPC-A-610.
2. ASSEMBLY PROCESS SHALL INCLUDE: REFLOW SOLDER TOP SIDE SMD. MAXIMUM SOLDER TEMPERATURE IS 240 DEGREES CELSIUS.
3. PARTS TO OMIT WILL BE SPECIFIED ON THE BILL OF MATERIALS. LOCATIONS OF OMITTED PARTS SHALL BE FREE OF SOLDER. MASK THE SOLDER STENCIL WHERE SMT PARTS ARE OMITTED.
4. INSTALL SHUNTS AS SHOWN ON ASSY DRAWING.
5. DEPANELIZE BOARDS AFTER ASSEMBLY AND ROUTE-OUT THE BREAKOUT TABS ON FOUR SIDES OF THE BOARD EDGE.
6. DO NOT APPLY ANY KIND OF ASSEMBLY STAMP OR QA STAMP TO ANY BOARD.
7. INSTALL D1 AS SHOWN BELOW:

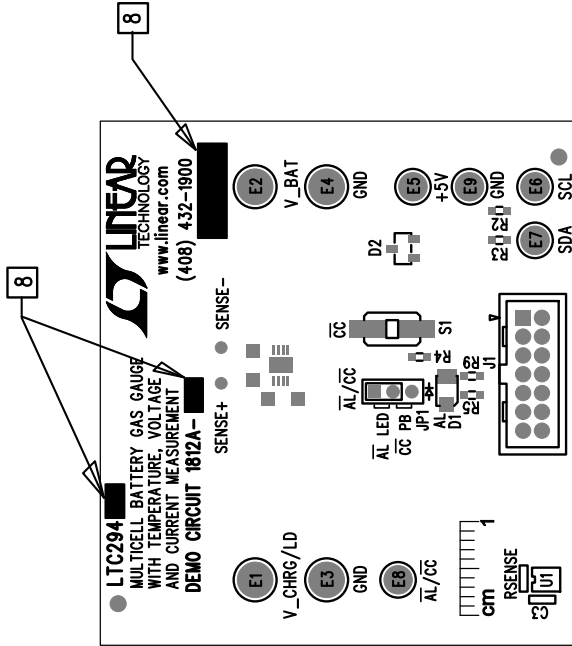

APPROVALS	
PCB DES.	LT
APP ENG.	S. AFZAL
TITLE: TOP ASSEMBLY DRAWING MULTICELL BATTERY GAS GAUGE WITH TEMPERATURE, VOLTAGE AND CURRENT MEASUREMENT	
SIZE	LTC294XCDD
REV.	3
SCALE = NONE	
FILENAME: DC1812A-3.PCB	
SHT 1 OF 2	

LINEAR TECHNOLOGY
1630 MCCARTHY BLVD
MILPITAS, CA 95035
PH: (408) 432-1900
www.linear.com
LTC CONFIDENTIAL -
FOR CUSTOMER USE ONLY

8 MARK EACH SUFFIX AND V_BAT ASSEMBLY TYPE WITH BLACK PERMANENT MARKER AS SHOWN IN TABLE BELOW:

ASSY	U1	SUFFIX	V_BAT
-A	LTC2943	3	3.6V-20V
-B	LTC2944	4	3.6V-60V
-C	LTC2943-1	3-1	3.6V-20V

DEMO MANUAL DC1812A

DEMONSTRATION BOARD IMPORTANT NOTICE

Linear Technology Corporation (LTC) provides the enclosed product(s) under the following **AS IS** conditions:

This demonstration board (DEMO BOARD) kit being sold or provided by Linear Technology is intended for use for **ENGINEERING DEVELOPMENT OR EVALUATION PURPOSES ONLY** and is not provided by LTC for commercial use. As such, the DEMO BOARD herein may not be complete in terms of required design-, marketing-, and/or manufacturing-related protective considerations, including but not limited to product safety measures typically found in finished commercial goods. As a prototype, this product does not fall within the scope of the European Union directive on electromagnetic compatibility and therefore may or may not meet the technical requirements of the directive, or other regulations.

If this evaluation kit does not meet the specifications recited in the DEMO BOARD manual the kit may be returned within 30 days from the date of delivery for a full refund. **THE FOREGOING WARRANTY IS THE EXCLUSIVE WARRANTY MADE BY THE SELLER TO BUYER AND IS IN LIEU OF ALL OTHER WARRANTIES, EXPRESSED, IMPLIED, OR STATUTORY, INCLUDING ANY WARRANTY OF MERCHANTABILITY OR FITNESS FOR ANY PARTICULAR PURPOSE. EXCEPT TO THE EXTENT OF THIS INDEMNITY, NEITHER PARTY SHALL BE LIABLE TO THE OTHER FOR ANY INDIRECT, SPECIAL, INCIDENTAL, OR CONSEQUENTIAL DAMAGES.**

The user assumes all responsibility and liability for proper and safe handling of the goods. Further, the user releases LTC from all claims arising from the handling or use of the goods. Due to the open construction of the product, it is the user's responsibility to take any and all appropriate precautions with regard to electrostatic discharge. Also be aware that the products herein may not be regulatory compliant or agency certified (FCC, UL, CE, etc.).

No License is granted under any patent right or other intellectual property whatsoever. **LTC assumes no liability for applications assistance, customer product design, software performance, or infringement of patents or any other intellectual property rights of any kind.**

LTC currently services a variety of customers for products around the world, and therefore this transaction **is not exclusive**.

Please read the DEMO BOARD manual prior to handling the product. Persons handling this product must have electronics training and observe good laboratory practice standards. **Common sense is encouraged.**

This notice contains important safety information about temperatures and voltages. For further safety concerns, please contact a LTC application engineer.

Mailing Address:

Linear Technology
1630 McCarthy Blvd.
Milpitas, CA 95035

Copyright © 2004, Linear Technology Corporation