



Chipsmall Limited consists of a professional team with an average of over 10 year of expertise in the distribution of electronic components. Based in Hongkong, we have already established firm and mutual-benefit business relationships with customers from,Europe,America and south Asia,supplying obsolete and hard-to-find components to meet their specific needs.

With the principle of “Quality Parts,Customers Priority,Honest Operation,and Considerate Service”,our business mainly focus on the distribution of electronic components. Line cards we deal with include Microchip,ALPS,ROHM,Xilinx,Pulse,ON,Everlight and Freescale. Main products comprise IC,Modules,Potentiometer,IC Socket,Relay,Connector.Our parts cover such applications as commercial,industrial, and automotives areas.

We are looking forward to setting up business relationship with you and hope to provide you with the best service and solution. Let us make a better world for our industry!



## Contact us

Tel: +86-755-8981 8866 Fax: +86-755-8427 6832

Email & Skype: info@chipsmall.com Web: www.chipsmall.com

Address: A1208, Overseas Decoration Building, #122 Zhenhua RD., Futian, Shenzhen, China



# High Power Constant Current, Constant Voltage Synchronous Buck Controller

## DESCRIPTION

Demonstration circuit 1831A is a high power constant current, constant voltage synchronous buck controller featuring the LT<sup>®</sup>3763. The input of the demo board is up to 60V. The output is optimized for 10V, 10A as a LED driver. As an LED driver, the output current is being regulated until the output voltage reaches a programmed voltage limit. The voltage limit on the demo board is set to around 15V by R11 and R14. The load to be used with this demo board is high current LEDs or laser diodes. Smaller LEDs may not be able to handle the high current, even for a short period of time. It is necessary to mount the LED load on a proper heat sink. A fan may become necessary to avoid exceeding LED's maximum temperature rating.

The input voltage range of the LT3763 itself is 6V to 60V. The demo board input range is 12V to 60V, therefore, the demo board utilizes 80V MOSFETs. If an application has a maximum input voltage of 48V, 60V MOSFETs such as BSC100N06LS3, can be used for better efficiency at lower voltage range. The typical efficiency of the demo board is 95% from a 24V input to a 10V, 10A load. The lower the input voltage, the higher the efficiency tends to be for a given load. At an output power level of 100W, even a one percent efficiency improvement is a big advantage in minimizing temperature rise. If an efficiency measurement is needed in an application, the output voltage must be measured at the output capacitors instead of at the LED load. This prevents cable loss from being counted as a loss of the board. The LT3763 turns off unnecessary circuits during PWM off period to minimize power losses. As a result, efficiency in many PWM dimming applications is high.

In most applications, input voltage reaching the maximum specification is a transient event. However, a fan helps the circuit to stay cool if running at or near peak input voltage at full load in steady state. If running in steady state at or near maximum input voltage and full load is required, please contact LTC applications engineering.

The demo circuit 1831A achieves fast current rise time from 0A to 10A. To see the real rise time, connecting wires between the LED and the board should be as short as possible to minimize the wire inductance and resistance. The cathode of the LED should return to LED- with R17 populated with a resistor in a few m $\Omega$ . It is recommended to measure the voltage on R17 with a short 50 $\Omega$  coax cable directly into a BNC connector on the oscilloscope. The current can be calculated from the measured voltage. A current probe adds more delays to the rise time so using a current probe is not recommended. If fast rise time is not required, the cathode of the LED can be connected to GND as shown in Figure 2.

The LT3763 data sheet gives a complete description of the part, operation and application information. The data sheet must be read in conjunction with this quick start guide for demo circuit 1831A.

**Design files for this circuit board are available at <http://www.linear.com/demo>**

LT, LT, LTC, LTM, Linear Technology and the Linear logo are registered trademarks of Linear Technology Corporation. All other trademarks are the property of their respective owners.

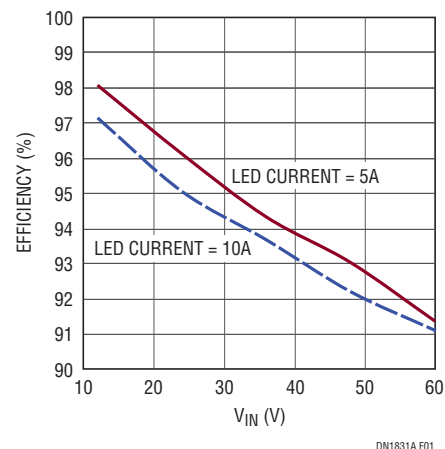

**Figure 1. Demo Board Efficiency**

## PERFORMANCE SUMMARY (T<sub>A</sub> = 25°C)

SYMBOL	PARAMETER	CONDITIONS	MIN	TYP	MAX	UNITS
V <sub>IN</sub>	Input Supply Range		12		60	V
V <sub>OUT</sub>	Maximum Output Voltage			15		V
I <sub>OUT</sub>	Output Current		9.4	10	10.6	A
f <sub>SW</sub>	Switching Frequency		380	430	480	kHz
EFF	Efficiency at DC	I <sub>OUT</sub> = 10A, V <sub>OUT</sub> = 10V		95		%

---

## QUICK START PROCEDURE

Demonstration circuit 1831A is easy to set up to evaluate the performance of the LT3763. Refer to Figure 2 for proper measurement equipment setup and follow the procedure below:

1. With power off, connect the input power supply to V<sub>IN</sub> and GND. Note: make sure V<sub>IN</sub> is below 60V.
2. With power off, connect the LED load to V<sub>OUT</sub> and GND (without PWM dimming) or V<sub>OUT</sub> and LED– (with PWM dimming).
3. When measuring input and output voltage, measure at test points TP1 to TP4.
4. Turn on the power at the input.
5. Carefully evaluate other design parameters as needed.

**QUICK START PROCEDURE**

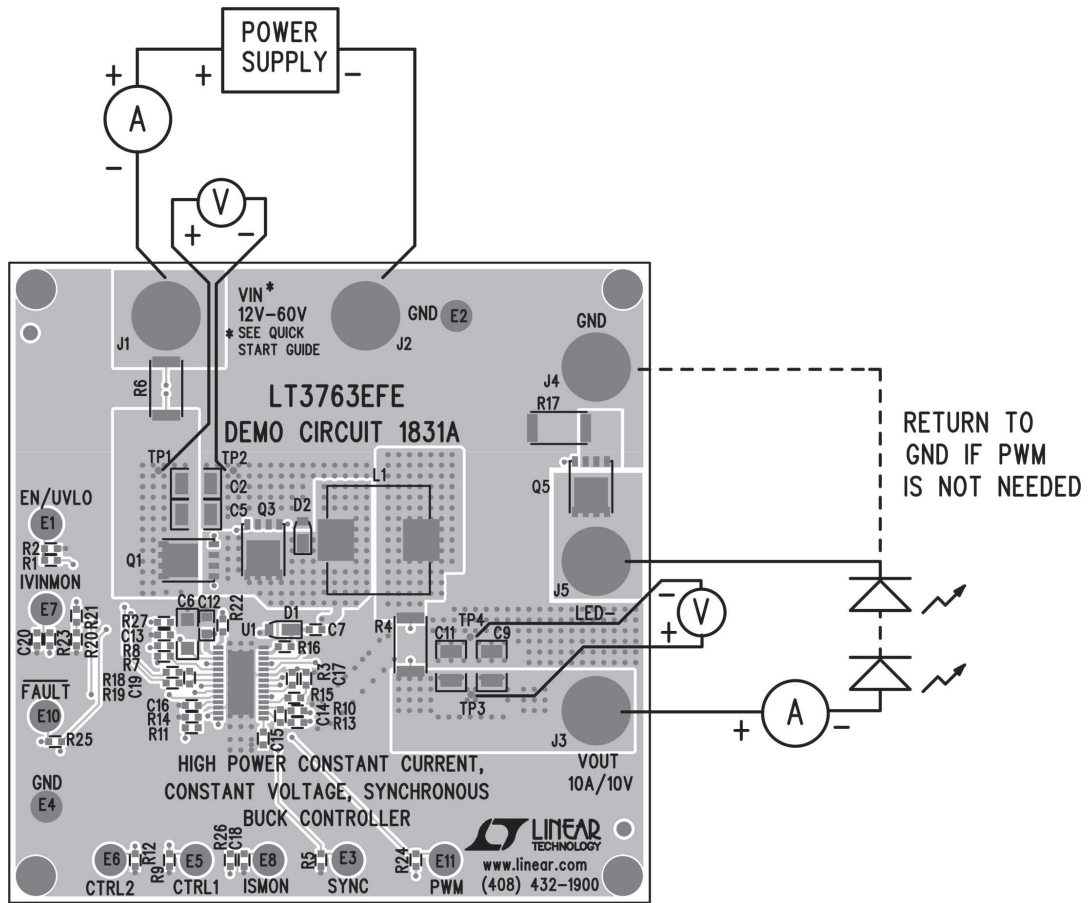

Figure 2. Proper Measurement Equipment Setup

# DEMO MANUAL DC1831A

## PARTS LIST

ITEM	QTY	REFERENCE	PART DESCRIPTION	MANUFACTURER/PART NUMBER
<b>Required Circuit Components</b>				
1	1	C1	Cap., Alum, 33 $\mu$ F, 100V, 10.3x10.3	Sun Elect., 100CE33FS
2	2	C2, C5	Cap., X7R, 2.2 $\mu$ F, 100V, 10%, 1210	Murata, GRM32ER72A225KE35L
3	1	C6	Cap., X7R, 1 $\mu$ F, 100V, 10%, 1206	Murata, GRM31CR72A105KA01L
4	1	C7	Cap., X7R, 0.22 $\mu$ F, 10V, 10%, 0603	Murata, GRM188R71A224KA01D
5	2	C8, C10	Cap., POSCAP, 68 $\mu$ F, 16V	Sanyo, 16TQC68MYF
6	2	C9, C11	Cap., X7R, 22 $\mu$ F, 25V, 10%, 1210	Murata, GRM32ER71E226KE15L
7	1	C12	Cap., X5R, 22 $\mu$ F, 6.3V, 10%, 0805	Murata, GRM21BR60J226ME39L
8	1	C13	Cap., COG, 2nF, 50V, 5%, 0603	Murata, GRM1885C1H202JA01D
9	2	C14, C19	Cap., X7R, 1000pF, 50V, 10%, 0603	AVX, 06035C102KAT2A
10	1	C15	Cap., X7R, 10nF, 16V, 0603	Murata, GRM188R71C103KA01D
11	1	C17	Cap., X7R, 5.1nF, 10%, 25V, 0603	Murata, GRM188R71E512KA01
12	1	D1	1.0A Schottky Diode, DFSL160	Diodes/Zetex, DFSL160-7
13	1	D2	2.0A Schottky Diode, DFSL260	Diodes/Zetex, DFSL260-7
14	1	L1	Inductor, 2.8 $\mu$ H	WE., 7443551280
15	4	Q1, Q2, Q3, Q4	MOSFET	Renesas, RJK0851DPB
16	1	Q5	MOSFET	Infineon, BSC014N03LS G
17	1	R1	Res., Chip, 374k, 1%, 0603	Vishay, CRCW0603374KFKEA
18	1	R2	Res., Chip, 124k, 1%, 0603	Vishay, CRCW0603124KFKEA
19	6	R3, R5, R8, R24, R25, R27	Res., Chip, 100k, 1%, 0603	Vishay, CRCW0603100KFKEA
20	1	R4	Res., Chip, 0.005 $\Omega$ , 1W, 1%, 2512	Vishay, WSL25125L000FEA
21	1	R7	Res., Chip, 45.3k, 1%, 0603	Vishay, CRCW0603453KFKEA
22	1	R11	Res., Chip, 5.62k, 1%, 0603	Vishay, CRCW06035K62FKEA
23	1	R12	Res., Chip, 680K, 1%, 0603	Vishay, CRCW0603680KFKEA
24	1	R14	Res., Chip, 487 $\Omega$ , 1%, 0603	Vishay, CRCW0603487RFKEA
25	1	R15	Res., Chip, 30.9k, 1%, 0603	Vishay, CRCW0603309KFKEA
26	1	U1	I.C. LT3763EFE, 20-Pin TSSOP	Linear Tech., LT3763EFE
<b>Additional Demo Board Circuit Components</b>				
1	0	C3, C4	Cap., 1210, Opt	
2	0	C16, C18, C20	Cap., 0603, Opt	
3	2	R6, R17	Res., Chip, 0 $\Omega$ , 2512	Vishay, CRCW25120000Z0EG
4	0	R9, R20, R21	Res., 1206, Opt	
5	8	R10, R13, R16, R18, R19, R22, R23, R26	Res., Chip, 0 $\Omega$ , 0603	Vishay, CRCW06030000Z0ED
<b>Hardware—For Demo Board Only</b>				
1	5	J1, J2, J3, J4, J5	Jack, Banana	Keystone, 575-4
2	10	E1-E8, E10, E11	Testpoint, Turret, 0.094"	Mill-Max, 2501-2-00-80-00-00-07-0
3	4		Stand-Off, Nylon 0.5" tall	Keystone, 8833 (Snap On)

**SCHEMATIC DIAGRAM**

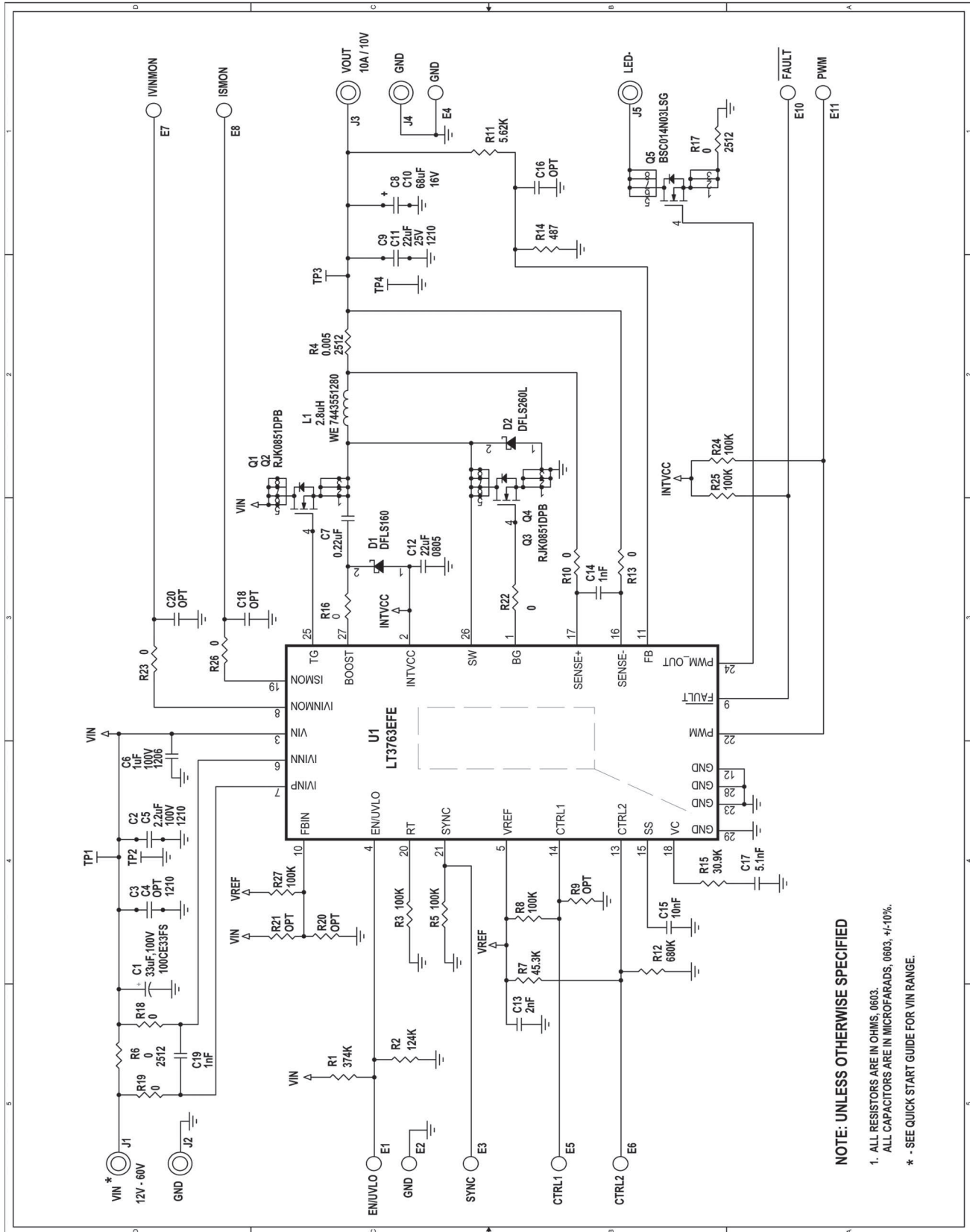

**NOTE: UNLESS OTHERWISE SPECIFIED**  
 1. ALL RESISTORS ARE IN OHMS, 0603.  
 ALL CAPACITORS ARE IN MICROFARADS, 0603, +/-10%.  
 \* - SEE QUICK START GUIDE FOR VIN RANGE.

# DEMO MANUAL DC1831A

---

## DEMONSTRATION BOARD IMPORTANT NOTICE

Linear Technology Corporation (LTC) provides the enclosed product(s) under the following **AS IS** conditions:

This demonstration board (DEMO BOARD) kit being sold or provided by Linear Technology is intended for use for **ENGINEERING DEVELOPMENT OR EVALUATION PURPOSES ONLY** and is not provided by LTC for commercial use. As such, the DEMO BOARD herein may not be complete in terms of required design-, marketing-, and/or manufacturing-related protective considerations, including but not limited to product safety measures typically found in finished commercial goods. As a prototype, this product does not fall within the scope of the European Union directive on electromagnetic compatibility and therefore may or may not meet the technical requirements of the directive, or other regulations.

If this evaluation kit does not meet the specifications recited in the DEMO BOARD manual the kit may be returned within 30 days from the date of delivery for a full refund. **THE FOREGOING WARRANTY IS THE EXCLUSIVE WARRANTY MADE BY THE SELLER TO BUYER AND IS IN LIEU OF ALL OTHER WARRANTIES, EXPRESSED, IMPLIED, OR STATUTORY, INCLUDING ANY WARRANTY OF MERCHANTABILITY OR FITNESS FOR ANY PARTICULAR PURPOSE. EXCEPT TO THE EXTENT OF THIS INDEMNITY, NEITHER PARTY SHALL BE LIABLE TO THE OTHER FOR ANY INDIRECT, SPECIAL, INCIDENTAL, OR CONSEQUENTIAL DAMAGES.**

The user assumes all responsibility and liability for proper and safe handling of the goods. Further, the user releases LTC from all claims arising from the handling or use of the goods. Due to the open construction of the product, it is the user's responsibility to take any and all appropriate precautions with regard to electrostatic discharge. Also be aware that the products herein may not be regulatory compliant or agency certified (FCC, UL, CE, etc.).

No License is granted under any patent right or other intellectual property whatsoever. **LTC assumes no liability for applications assistance, customer product design, software performance, or infringement of patents or any other intellectual property rights of any kind.**

LTC currently services a variety of customers for products around the world, and therefore this transaction **is not exclusive**.

**Please read the DEMO BOARD manual prior to handling the product.** Persons handling this product must have electronics training and observe good laboratory practice standards. **Common sense is encouraged.**

This notice contains important safety information about temperatures and voltages. For further safety concerns, please contact a LTC application engineer.

Mailing Address:

Linear Technology  
1630 McCarthy Blvd.  
Milpitas, CA 95035

Copyright © 2004, Linear Technology Corporation