



Chipsmall Limited consists of a professional team with an average of over 10 year of expertise in the distribution of electronic components. Based in Hongkong, we have already established firm and mutual-benefit business relationships with customers from,Europe,America and south Asia,supplying obsolete and hard-to-find components to meet their specific needs.

With the principle of “Quality Parts,Customers Priority,Honest Operation,and Considerate Service”,our business mainly focus on the distribution of electronic components. Line cards we deal with include Microchip,ALPS,ROHM,Xilinx,Pulse,ON,Everlight and Freescale. Main products comprise IC,Modules,Potentiometer,IC Socket,Relay,Connector.Our parts cover such applications as commercial,industrial, and automotives areas.

We are looking forward to setting up business relationship with you and hope to provide you with the best service and solution. Let us make a better world for our industry!



## Contact us

Tel: +86-755-8981 8866 Fax: +86-755-8427 6832

Email & Skype: info@chipsmall.com Web: www.chipsmall.com

Address: A1208, Overseas Decoration Building, #122 Zhenhua RD., Futian, Shenzhen, China



## DESCRIPTION

Demonstration circuit 2020A is a 60V<sub>IN</sub>, 80V<sub>OUT</sub> LED driver. It generates its own PWMOUT waveform from its internal PWM generator for accurate PWM dimming with up to 33:1 brightness ratio. It accepts an input voltage from 5V to 60V and drives up to 67V of LEDs at 300mA (when  $PV_{IN}$  is less than  $V_{LED}$ ). DC2020A features both PWM and analog dimming of the LED string. It has an OPENLED flag that indicates when the LED string has been removed.

DC2020A features high efficiency at 350kHz switching frequency. At high LED string voltages up to 67V and 300mA of LED current, the single switch controller has 92% efficiency. The LT3955 has an internal 80V, 3.5A switch that simplifies the schematic and layout.

Small ceramic input and output capacitors are used to save space and cost. The open LED overvoltage protection uses the IC's constant voltage regulation loop to regulate the output to approximately 75V if the LED string is opened although it may reach 79V peak during transient from running LEDs to open string.

For low input voltage operation, the CTRL pin voltage is reduced as the input voltage drops below 9V, reducing LED brightness and restraining the peak switch currents in order to limit inductor and switch size. UVLO turns the LEDs off when  $V_{IN}$  drops below 5V.

DC2020A PWM dimming is simplified when compared with other LED drivers. The LT3955 generates its own PWMOUT dimming waveform at a frequency determined

by the capacitance on the PWM pin (C16 gives 320Hz for DC2020A). The PWMOUT duty cycle is determined by the voltage on the DIM terminal. Between 0V and 7.7V  $V_{DIM}$  gives between 4% and 96% PWM duty cycle. Information regarding PWM dimming ratios and performance can be found in the LT3955 data sheet in the applications section. Analog dimming is also simple to use with a single voltage source on the CTRL terminal.

Modifications can be made to DC2020A in order to convert the board to power different LED strings or from an LED driver to a constant voltage regulator or battery charger. It can easily be changed from a boost topology to a SEPIC, buck mode, or buck-boost mode LED driver. Please consult the factory or the LT3955 data sheet for details. It can be modified to provide LED<sup>+</sup> to GND short-circuit protection as well.

The LT3955 data sheet gives a complete description of the part, operation and applications information. The data sheet must be read in conjunction with this demo manual for demonstration circuit DC2020A. The LT3955EUHE is assembled in a 36-lead plastic QFN package with two thermal pads underneath the IC. Proper board layout is essential for maximum thermal performance. See the data sheet section Layout Considerations.

**Design files for this circuit board are available at <http://www.linear.com/demo>**

LT, LT, LTC, LTM, Linear Technology and the Linear logo are registered trademarks of Linear Technology Corporation. All other trademarks are the property of their respective owners.



# DEMO MANUAL DC2020A

## PERFORMANCE SUMMARY Specifications are at $T_A = 25^\circ\text{C}$

PARAMETER	CONDITIONS	VALUE (TYPICAL)
Input Voltage $PV_{IN}$ Range	Operating	5V to $V_{LED}$ (up to 60V)
Switching Frequency	$R1 = 28.7k$	350kHz
$I_{LED}$	$RS1 = 0.82\Omega$ $9V < PV_{IN} < V_{LED}$ (60V)	300mA
Low $PV_{IN}$ $I_{LED}$ (CTRL foldback)	$RS1 = 0.82\Omega$ $PV_{IN} = 7.0V$ $RS1 = 0.82\Omega$ $PV_{IN} = 8.0V$	240mA 278mA
$V_{LED}$ Range	$R7 = 1M$ $R8 = 16.9k$	$PV_{IN} < V_{LED} < 67V$
Open LED Voltage	$R7 = 1M$ $R8 = 16.9k$	75V
Typical Efficiency	$PV_{IN} = 14V$ $V_{LED} = 67V$ $I_{LED} = 300mA$ $PWM = INTV_{CC}$	92.1%
$PV_{IN}$ Under Voltage Lockout (falling turn-off)	$R3 = 499k$ and $R4 = 165k$	5.0V
$PV_{IN}$ Under Voltage Lockout (rising turn-on)	$R3 = 499k$ and $R4 = 165k$	6.1V
$INTV_{CC}$	Operating	7.85V
Peak Switch Current Limit		3.3A
PWMOUT Dimming Duty Cycle	$VDIM = 7.7V$ $VDIM = 4.0V$ $VDIM = 1.5V$ $VDIM = 0.4V$	96% 50% 10% 4.3%
Internal PWM Dimming Frequency	$C16 = 0.047\mu F$ $0V < VDIM < 8V$	300Hz

## QUICK START PROCEDURE

Demonstration circuit DC2020A is easy to set up to evaluate the performance of the LT3955EUHE. Follow the procedure below:

1. Connect a string of LEDs that will run with forward voltage less than or equal to 67V, but greater than the intended  $PV_{IN}$ , to the  $LED^+$  and  $LED^-$  terminals on the PCB as shown in Figure 1.
2. Connect the EN/UVLO terminal to GND.
3. With power off, connect the input power supply to the  $PV_{IN}$  and GND terminals. Make sure that the  $PV_{IN}$  DC input voltage will not exceed 60V (or  $V_{LED}$ ).
4. Connect the DIM terminal to a voltage between 0V and 8V to set the internal PWMOUT dimming duty cycle. If this terminal is left floating the converter will run with approximately 12% PWMOUT dimming duty cycle. Pull the PWM terminal high to  $INTV_{CC}$  to set the converter at 100% duty cycle.
5. Turn the input power supply on and make sure the voltage is between 6.1V and 60V (or  $V_{LED}$ ) to start.
6. Release the EN/UVLO-to-GND connection.
7. Observe the LED string running at the programmed LED current and brightness related to the programmed PWMOUT duty cycle.
8. To change the brightness with PWM dimming, simply vary the VDIM voltage between 0V and 8V with the PWM terminal floating.
9. To change the brightness with analog dimming, simply attach a voltage source on the CTRL terminal and reduce the voltage below 1.2V.
10. Observe the reduction of brightness in the LED string when PWM or analog dimming.

QUICK START PROCEDURE

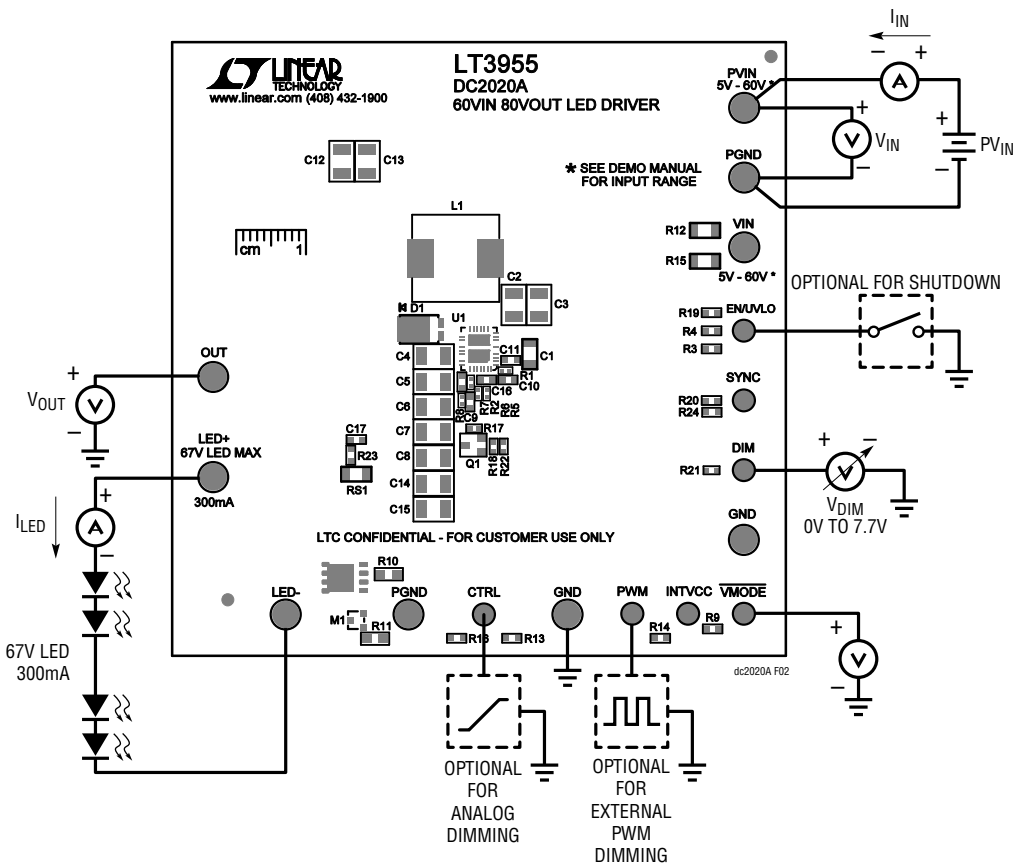

Figure 1. Test Procedure Setup Drawing for DC2020A

## QUICK START PROCEDURE

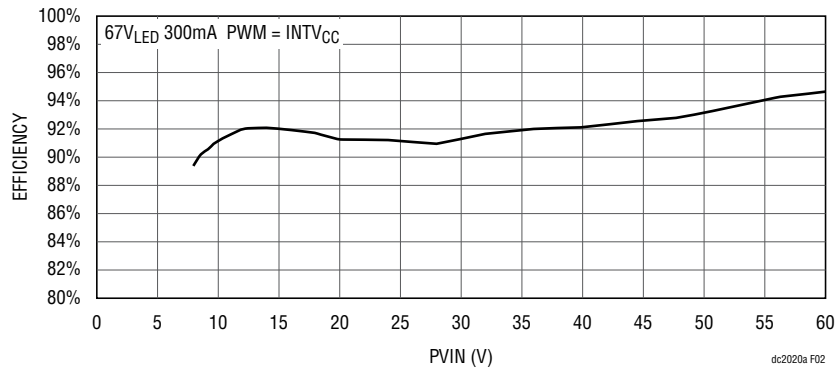

Figure 2. DC2020A Efficiency with 67V LEDs at 300mA and 100% PWMOUT Duty Cycle

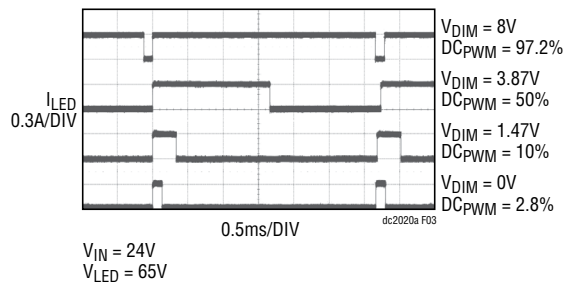
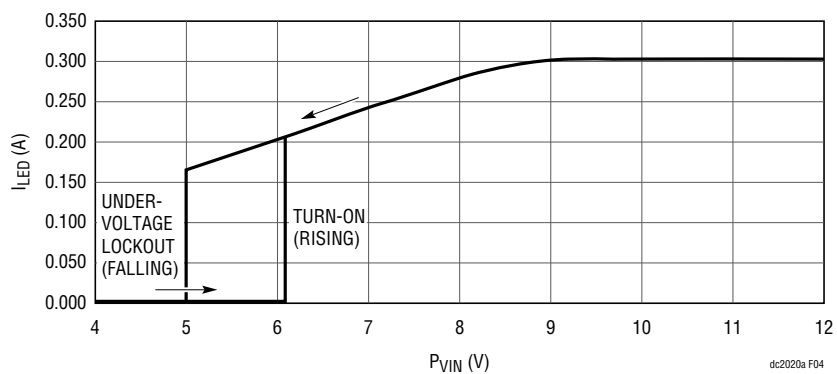

Figure 3. DC2020A 300Hz PWM Dimming Waveforms at Different PWMOUT Duty Cycles

**QUICK START PROCEDURE**



**Figure 4. DC2020A CTRL LED Current Foldback at Low PVIN with UVLO (Falling and Rising)**

# DEMO MANUAL DC2020A

## PARTS LIST

ITEM	QTY	REFERENCE	PART DESCRIPTION	MANUFACTURER/PART NUMBER
<b>Required Circuit Components</b>				
1	1	C1	CAP, 1206, 1 $\mu$ F, 20%, 100V, X7R	TDK C3216X7R2A105MT
2	2	C2, C3	CAP, 1210, 4.7 $\mu$ F, 10%, 100V, X7S	TDK C3225X7S2A475K
3	4	C4, C5, C6, C7	CAP, 1210, 2.2 $\mu$ F, 20%, 100V, X7R	TDK C3225X7R2A225M
4	0	C8, C14, C15	CAP, 1210, 2.2 $\mu$ F, 20%, 100V, X7R, OPTION	TDK C3225X7R2A225M OPTION
5	1	C9	CAP, 0603, 4.7nF, 20%, 25V, X7R	AVX 06033C472MAT2A
6	1	C10	CAP, 0603, 0.01 $\mu$ F, 10%, 25V, X7R	AVX 06033C103KAT2A
7	1	C11	CAP, 0603, 1 $\mu$ F, 10%, 10V, X7R	Taiyo Yuden LMK107BJ105KA
8	1	C16	CAP, 0603, 47nF, 20%, 16V, X7R	Taiyo Yuden EMK107BJ473MA
9	1	D1	DIODE, SCHOTTKY	DIODES INC. PDS3100-13
10	1	L1	IND, 22 $\mu$ H, 20%	COOPER COILTRONICS DR125-220
11	1	M1	MOSFET N-CHANNEL 100V	VISHAY SILICONIX Si2328DS
12	1	RS1	RES, 1206, 0.82 $\Omega$ , 1%, 1/4W	IRC LR1206LF-01-R820FT
13	1	R1	RES, 0402, 28.7k $\Omega$ , 1%, 1/16W	VISHAY CRCW040228K7FKED
14	1	R2	RES, 0402, 5.1k $\Omega$ , 5%, 1/16W	VISHAY CRCW04025K10JNED
15	1	R3	RES, 0603, 499k $\Omega$ , 1%, 1/16W	VISHAY CRCW0603499KFKEA
16	1	R4	RES, 0402, 165k $\Omega$ , 1%, 1/16W	VISHAY CRCW0402165KFKEA
17	1	R5	RES, 0402, 1M $\Omega$ , 1%, 1/16W	VISHAY CRCW04021M00FKED
18	1	R6	RES, 0603, 147k $\Omega$ , 1%, 1/16W	VISHAY CRCW0603147KFKEA
19	1	R7	RES, 0603, 1M $\Omega$ , 1%, 1/16W	VISHAY CRCW06031M00FKEA
20	1	R8	RES, 0402, 16.9k $\Omega$ , 1%, 1/16W	VISHAY CRCW040216K9FKED
21	1	R9	RES, 0603, 100k $\Omega$ , 5%, 1/16W	VISHAY CRCW0603100KJNED
22	1	R21	RES, 0402 124k $\Omega$ , 1% 1/16W	VISHAY CRCW0402124KFKEA
23	1	U1	IC, 60V <sub>IN</sub> /80V <sub>OUT</sub> LED DRIVER	LINEAR TECH. LT3955EUHE
<b>Optional Electrical Components</b>				
1	0	C12, C13	CAP, 1210 OPTION	OPTION
2	0	C17	CAP., 0603 OPTION	
3	0	Q1	XSTR, OPTION	OPTION
4	0	R10	RES, 0805, OPTION	OPTION
5	1	R11	RES, 0805, 0 $\Omega$ , JUMPER	VISHAY CRCW08050000Z0EA
6	1	R12	RES, 1206, 0 $\Omega$ , JUMPER	VISHAY CRCW1206000Z
7	0	R13, R14, R16, R19, R20, R23	RES, 0603 OPTION	OPTION
8	0	R15	RES, 1206 OPTION	OPTION
9	0	R17, R18, R22	RES, 0402 OPTION	OPTION
10	1	R24	RES, 0603, 0 $\Omega$ JUMPER	VISHAY CRCW06030000Z0EA
<b>Optional Hardware</b>				
1	9	E1, E2, E3, E4, E5, E7, E8, E12, E13	TURRET	MILL MAX 2501-2-00-80-00-00-07-0
2	7	E6, E9, E10, E11, E14, E15, E16	TURRET	MILL MAX 2308-2-00-80-00-00-07-0

# SCHEMATIC DIAGRAM

# DEMO MANUAL DC2020A

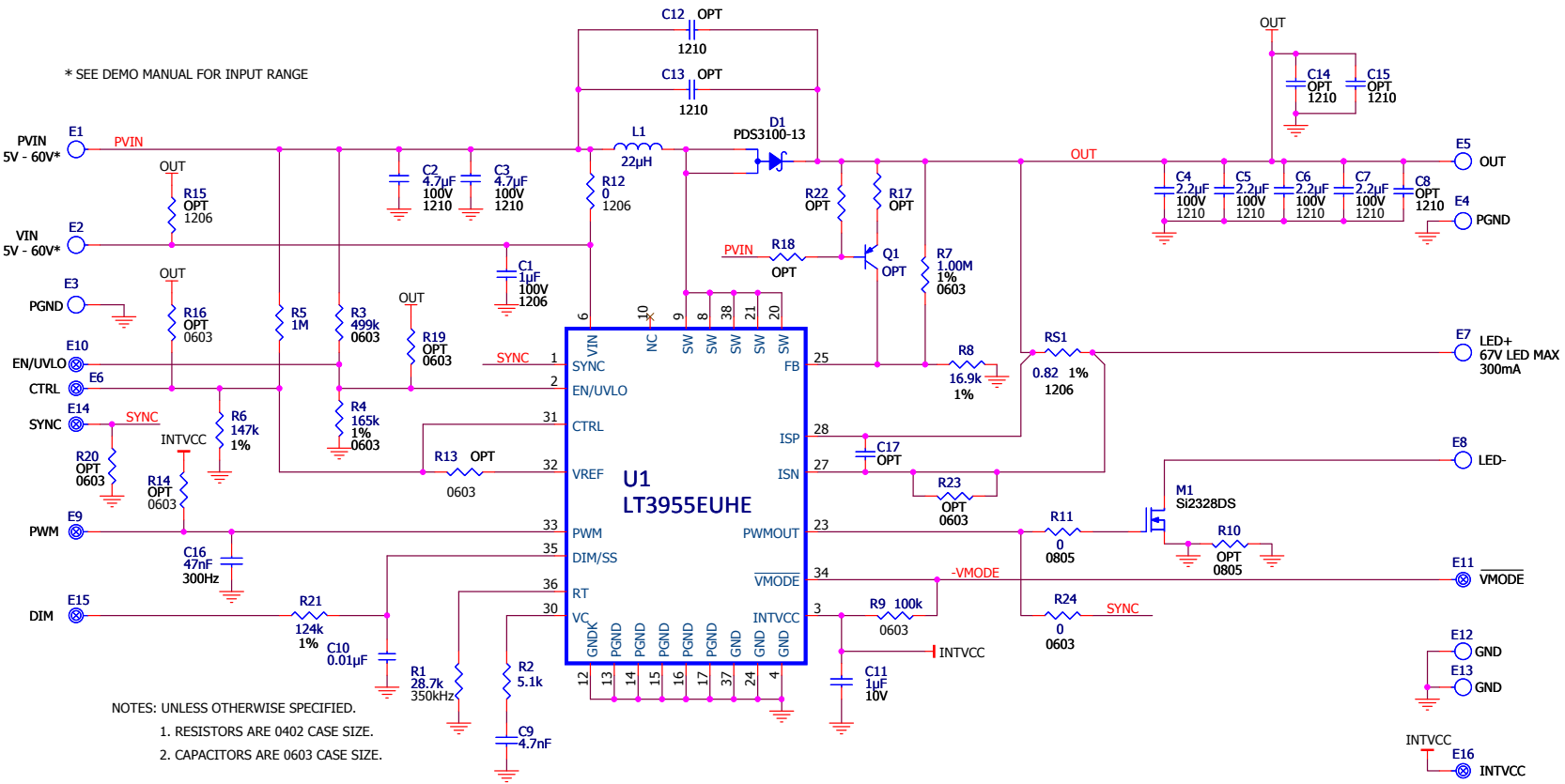



# DEMO MANUAL DC2020A

---

## DEMONSTRATION BOARD IMPORTANT NOTICE

Linear Technology Corporation (LTC) provides the enclosed product(s) under the following **AS IS** conditions:

This demonstration board (DEMO BOARD) kit being sold or provided by Linear Technology is intended for use for **ENGINEERING DEVELOPMENT OR EVALUATION PURPOSES ONLY** and is not provided by LTC for commercial use. As such, the DEMO BOARD herein may not be complete in terms of required design-, marketing-, and/or manufacturing-related protective considerations, including but not limited to product safety measures typically found in finished commercial goods. As a prototype, this product does not fall within the scope of the European Union directive on electromagnetic compatibility and therefore may or may not meet the technical requirements of the directive, or other regulations.

If this evaluation kit does not meet the specifications recited in the DEMO BOARD manual the kit may be returned within 30 days from the date of delivery for a full refund. **THE FOREGOING WARRANTY IS THE EXCLUSIVE WARRANTY MADE BY THE SELLER TO BUYER AND IS IN LIEU OF ALL OTHER WARRANTIES, EXPRESSED, IMPLIED, OR STATUTORY, INCLUDING ANY WARRANTY OF MERCHANTABILITY OR FITNESS FOR ANY PARTICULAR PURPOSE. EXCEPT TO THE EXTENT OF THIS INDEMNITY, NEITHER PARTY SHALL BE LIABLE TO THE OTHER FOR ANY INDIRECT, SPECIAL, INCIDENTAL, OR CONSEQUENTIAL DAMAGES.**

The user assumes all responsibility and liability for proper and safe handling of the goods. Further, the user releases LTC from all claims arising from the handling or use of the goods. Due to the open construction of the product, it is the user's responsibility to take any and all appropriate precautions with regard to electrostatic discharge. Also be aware that the products herein may not be regulatory compliant or agency certified (FCC, UL, CE, etc.).

No License is granted under any patent right or other intellectual property whatsoever. **LTC assumes no liability for applications assistance, customer product design, software performance, or infringement of patents or any other intellectual property rights of any kind.**

LTC currently services a variety of customers for products around the world, and therefore this transaction **is not exclusive**.

**Please read the DEMO BOARD manual prior to handling the product.** Persons handling this product must have electronics training and observe good laboratory practice standards. **Common sense is encouraged.**

This notice contains important safety information about temperatures and voltages. For further safety concerns, please contact a LTC application engineer.

Mailing Address:

Linear Technology  
1630 McCarthy Blvd.  
Milpitas, CA 95035

Copyright © 2004, Linear Technology Corporation