



Chipsmall Limited consists of a professional team with an average of over 10 year of expertise in the distribution of electronic components. Based in Hongkong, we have already established firm and mutual-benefit business relationships with customers from,Europe,America and south Asia,supplying obsolete and hard-to-find components to meet their specific needs.

With the principle of "Quality Parts,Customers Priority,Honest Operation,and Considerate Service",our business mainly focus on the distribution of electronic components. Line cards we deal with include Microchip,ALPS,ROHM,Xilinx,Pulse,ON,Everlight and Freescale. Main products comprise IC,Modules,Potentiometer,IC Socket,Relay,Connector.Our parts cover such applications as commercial,industrial, and automotives areas.

We are looking forward to setting up business relationship with you and hope to provide you with the best service and solution. Let us make a better world for our industry!



Contact us

Tel: +86-755-8981 8866 Fax: +86-755-8427 6832

Email & Skype: info@chipsmall.com Web: www.chipsmall.com

Address: A1208, Overseas Decoration Building, #122 Zhenhua RD., Futian, Shenzhen, China



LTC3880EUJ/LTC3883EUH 3-Phase Step-Down DC/DC Controller with Power System Management

DESCRIPTION

Demonstration circuit 2052A is a 3-phase single output synchronous buck converter featuring the LTC3880EUJ, a dual-phase current mode controller, and the LTC3883EUH, a single-phase current mode controller with input current sensing capability. Both the [LTC[®]3880](#) and [LTC3883](#) have a PMBus interface and the power system management functions.

The layout of DC2052A is very compact with the total solution within a 1.1 inch by 1.2 inch area for LTC3880, and 1.1 inch by 0.35inch for LTC3883. The input voltage range of this board is from 6.5V to 14V. The output voltage can be programmed from 0.5V to 1.8V, with an output current of up to 60A total. The factory default setting for the output voltage is 1.0V. The DC2052A also has an onboard pulse generator circuit and the dynamic load circuit which make it easy for the customer to evaluate the transient performances.

The DC2052A powers up to default settings and produces power based on configuration resistors or the non-volatile memory settings (NVM) without the need for any serial

bus communication. This allows easy evaluation of the DC/DC converter. To fully explore the extensive digital power management features of these parts, download the GUI software LTpowerPlay™ onto your PC and use LTC's I²C/SMBus/PMBus Dongle DC1613A to connect to the board. LTpowerPlay allows the user to reconfigure the part on the fly and store the configuration in EEPROM, view telemetry of voltage, current, temperature and fault status.

GUI Download

The software can be downloaded from:

<http://www.linear.com/ltpowerplay>

For more details and instructions of LTpowerPlay, please refer to "LTpowerPlay for LTC3880 Quick Start Guide."

Design files for this circuit board are available at
<http://www.linear.com/demo>

LT, LT, LTC, LTM, Linear Technology and the Linear logo are registered trademarks and LTpowerPlay is a trademark of Linear Technology Corporation. All other trademarks are the property of their respective owners.

PERFORMANCE SUMMARY Specifications are at T_A = 25°C

SYMBOL	PARAMETER	CONDITIONS	MIN	TYP	MAX	UNITS
V _{IN}	Input Supply Range		6.5	12	14	V
V _{OUT}	Output Voltage Range	I _{OUT} = 0A to 60A, V _{IN} = 6.5V to 14V	0.5	1.0	1.8	V
I _{OUT}	Output Current Range		0		60	A
F _{SW}	Factory Default Switching			350		kHz
EFF	Peak Efficiency	V _{OUT} = 1.0V, See Figure 4		87.5		%

QUICK START PROCEDURE

Demonstration circuit 2052A makes it easy to set up and evaluate the performance of the LTC3880 and the LTC3883. Refer to Figure 2 for proper measurement equipment setup and follow the procedure below:

Note: When measuring the input or output voltage ripple, care must be taken to avoid a long ground lead on the oscilloscope probe. Measure the output voltage ripple by touching the probe tip directly across the C16. See Figure 3 for proper scope probe technique.

1. Make sure jumpers are in the following positions:

JUMPER	POSITION	FUNCTION
JP1	OFF	EXTVCC_DRV – External V _{CC} for LTC3880/LTC3883-1
JP2	OFF	LED Indicator
JP3	OFF	Pulse Generator

2. With power off, connect the input power supply to VIN and GND. Connect active load to the output.

3. Make sure the RUN switch (SW) is OFF.

4. Turn on the power at the input.

Note: Make sure that the input voltage does not exceed 16V.

5. Turn on the RUN switch as desired.

6. Check for the correct output voltage from E3 to E4.
 $V_{OUT} = 1.0V \pm 0.5\%$ (1.005V ~ 0.995V)

Note: If there is no output, temporarily disconnect the load to make sure that the load is not set too high.

7. Once the proper output voltage is established, adjust the loads within the operating range and observe the output voltage regulation, ripple voltage, efficiency and other parameters.

8. Connect the dongle and control the output voltages from the GUI. See “LTpowerPlay QUICK START” session for details.

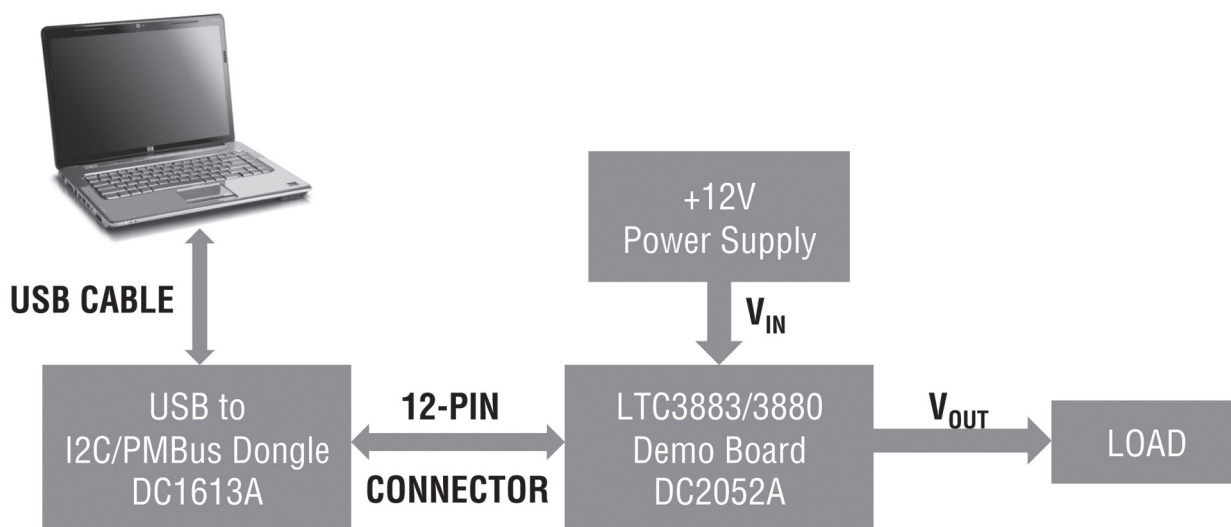

Figure 1. Demo Setup with PC

QUICK START PROCEDURE

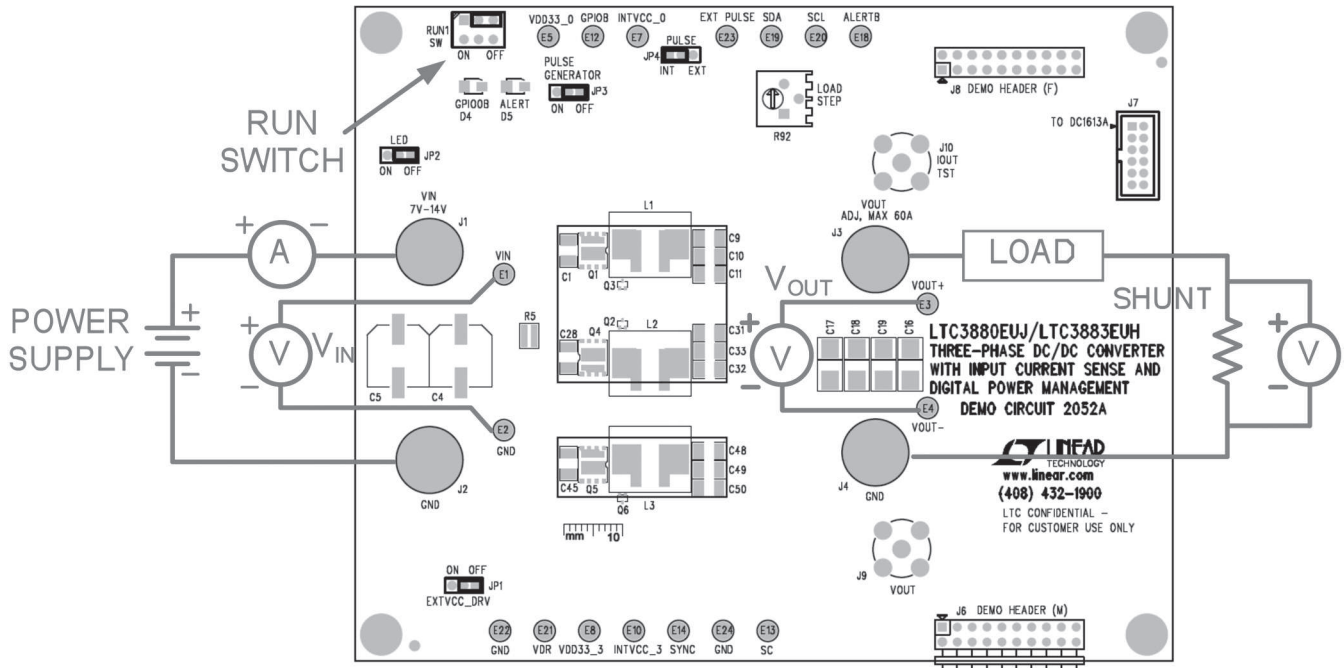

Figure 2. Power Test Setup

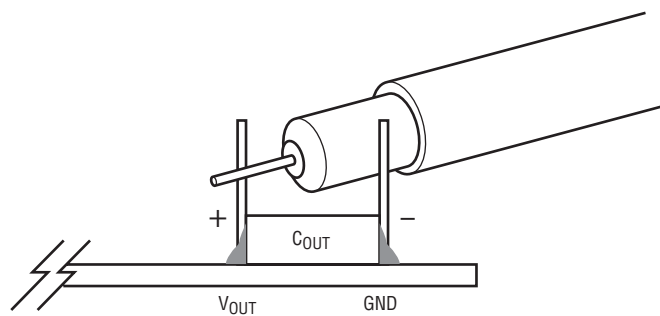

Figure 3. Measuring Output Voltage Ripple

QUICK START PROCEDURE

Connecting a PC to DC2052A

You can use a PC to reconfigure the power management features of the LTC3880 and the LTC3883 such as: nominal V_{OUT} , margin set points, OV/UV limits, temperature fault limits, sequencing parameters, the fault log, fault responses, GPIO and other functionality. The DC1613A dongle may be plugged in regardless of whether or not VIN is present. Dongle can be hot plugged.

Combining DC2052A with Other Digital Power Demo Boards

The DC2052A may be plugged together in a multiboard array with other LTC power system management boards using J6 and J8.

Measuring Efficiency (See Figure 4)

To accurately measure efficiency of any configuration, do the following:

- Set JP1, JP2, JP3 to OFF position to disable all the auxiliary circuits.
- Make sure R53, R54 are not stuffed.
- Measure V_{IN} across the input ceramic capacitor (C28). Measure V_{OUT} across the output ceramic capacitor (C32).

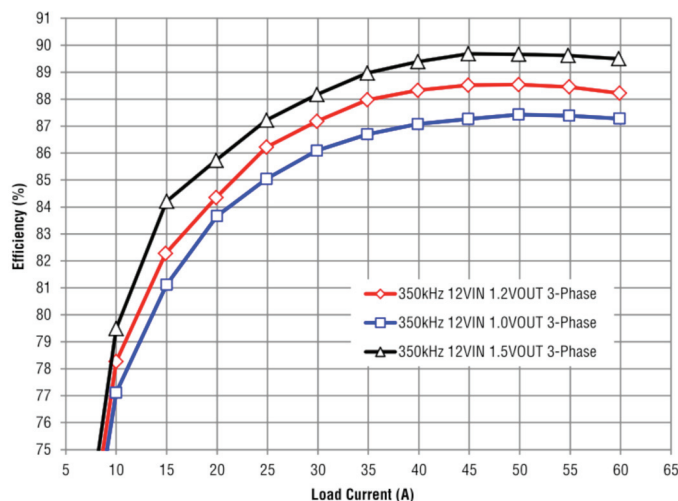

Figure 4. Typical Efficiency Curves DC2052A, 12VIN, $F_{SW} = 350\text{kHz}$, $V_{OUT} = 1.0\text{V}, 1.2\text{V}, 1.5\text{V}$

Evaluating the DC2052A When V_{IN} is Below 6.0V

For applications that the input voltage is within 4.5V to 6.0V, please install R5 to connect VIN directly to INTVCC. Please be aware that in this case VIN cannot exceed 6.0V otherwise the chip will be damaged.

Evaluating the LTC3880-1 and LTC3883-1

For applications that require the highest possible efficiency, the LTC3880-1 and LTC3883-1 allow the user to supply the bias voltage and gate driver current from an external power supply. Connect the external power supply, 4.8V to 5.2V, to the EXTVCC pin.

To use the onboard LDO to drive INTVCC, make the following modifications to the demo board:

- Set JP1 to ON so that U4 provides the 5V drive to INTVCC. U4 takes the place of the external power supply.
- Install R53, R54.

To accurately measure efficiency of a demo board containing the LTC3880-1 and the LTC3883-1,

- Drive INTVCC from an external source through the pin named: EXTVCC.
- Set JP1 to OFF to disable the LDO.
- Measure V_{IN} across the input ceramic capacitor (C28). Measure V_{OUT} across the output ceramic capacitor (C32).

Measuring Output Ripple Voltage

An accurate ripple measurement may be performed by using the below configuration across C16.

LTpowerPlay SOFTWARE GUI

LTpowerPlay is a powerful Windows-based development environment that supports Linear Technology power system management ICs, including the LTC3880, LTC3883, LTC2974 and LTC2978. The software supports a variety of different tasks. You can use LTpowerPlay to evaluate Linear Technology ICs by connecting to a demo board system. LTpowerPlay can also be used in an offline mode (with no hardware present) in order to build a multichip configuration file that can be saved and reloaded at a later time. LTpowerPlay provides unprecedented diagnostic and debug features. It becomes a valuable diagnostic tool during board bring-up to program or tweak the power management scheme in a system, or to diagnose power

issues when bringing up rails. LTpowerPlay utilizes the DC1613A USB-to-SMBus controller to communicate with one of many potential targets, including the LTC3880 and the LTC3883's DC2052A demo system, or a customer board. The software also provides an automatic update feature to keep the software current with the latest set of device drivers and documentation. The LTpowerPlay software can be downloaded from:

<http://linear.com/ltpowerplay>

To access technical support documents for LTC Digital Power Products visit Help. View online help on the LTpowerPlay menu.

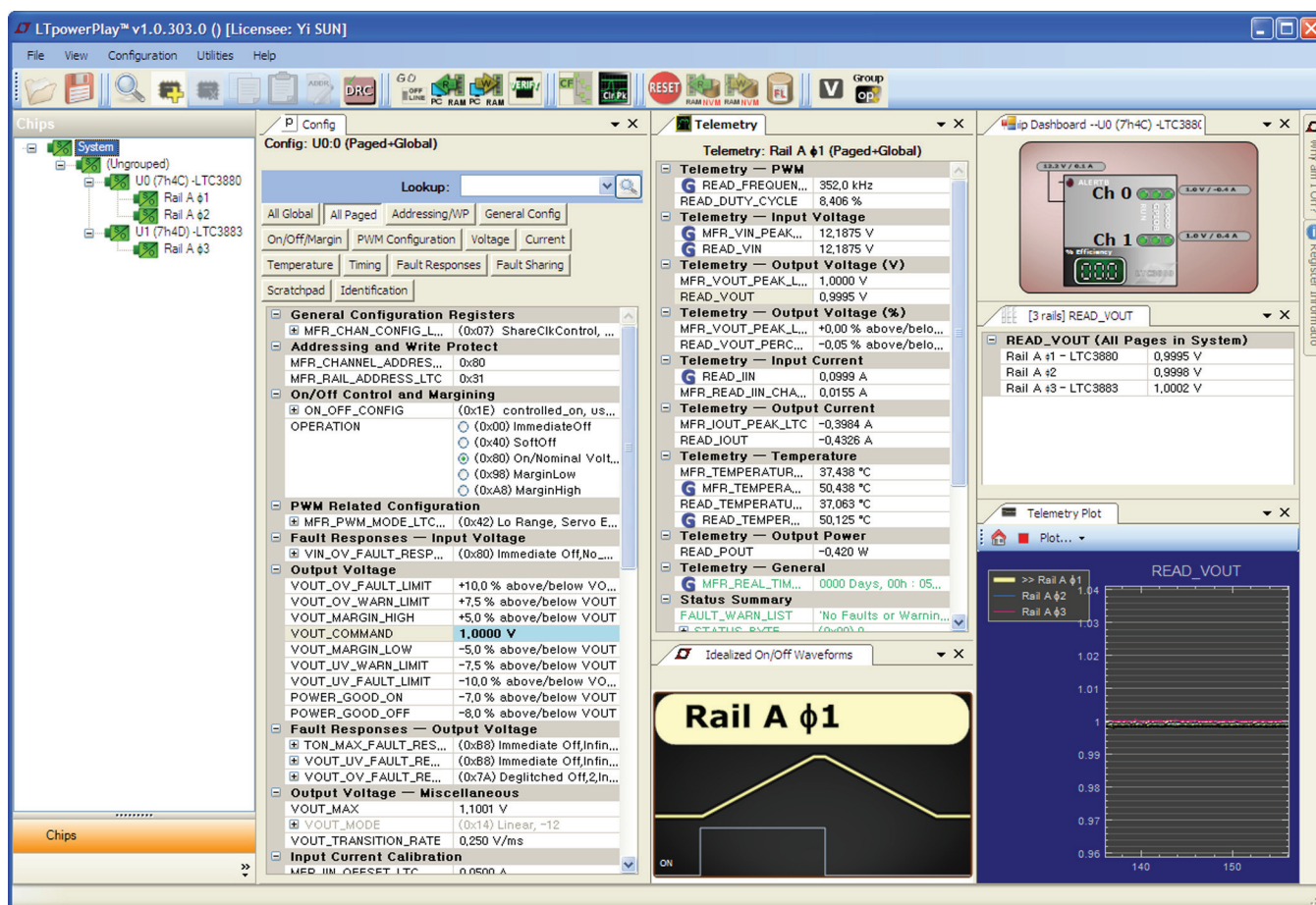

Figure 5. LTpowerPlay Main Interface

LTpowerPlay QUICK START PROCEDURE

The following procedure describes how to use LTpowerPlay to monitor and change the settings of LTC3880 and LTC3883.

1. Download and install the LTpowerPlay GUI:

<http://linear.com/ltpowerplay>

2. Launch the LTpowerPlay GUI.

- a. The GUI should automatically identify the DC2052A. The system tree on the left hand side should look like this:

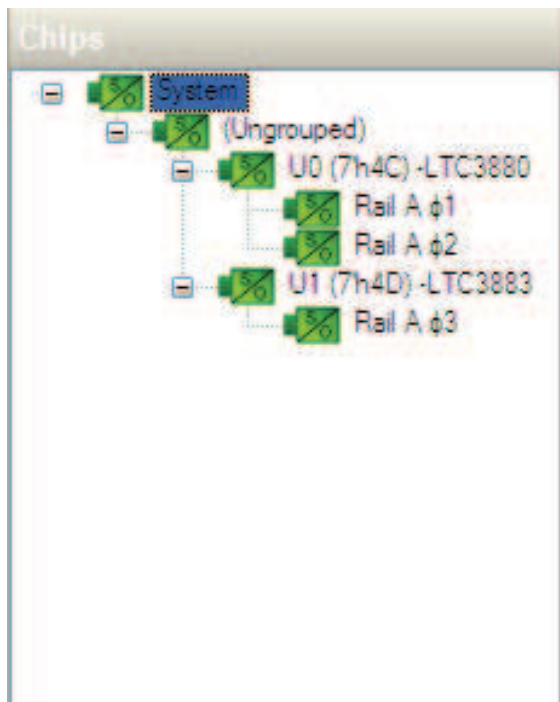

- b. A green message box shows for a few seconds in the lower left hand corner, confirming that the LTC3880 and the LTC3883 are communicating:

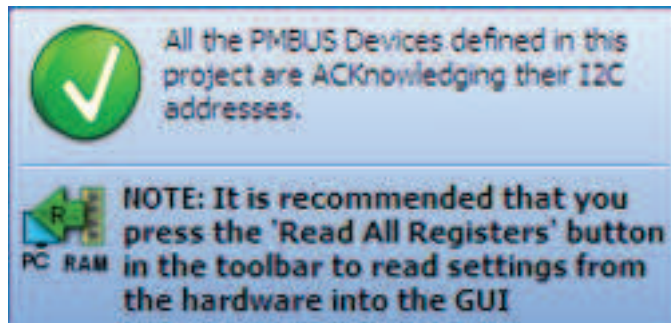

- c. In the Toolbar, click the “R” (RAM to PC) icon to read the RAM from the LTC3880 and the LTC3883. This reads the configuration from the RAM of LTC3883 and loads it into the GUI.



- d. If you want to change the output voltage to a different value, like 1.5V. In the Config tab, type in 1.5 in the VOUT_COMMAND box, like this:

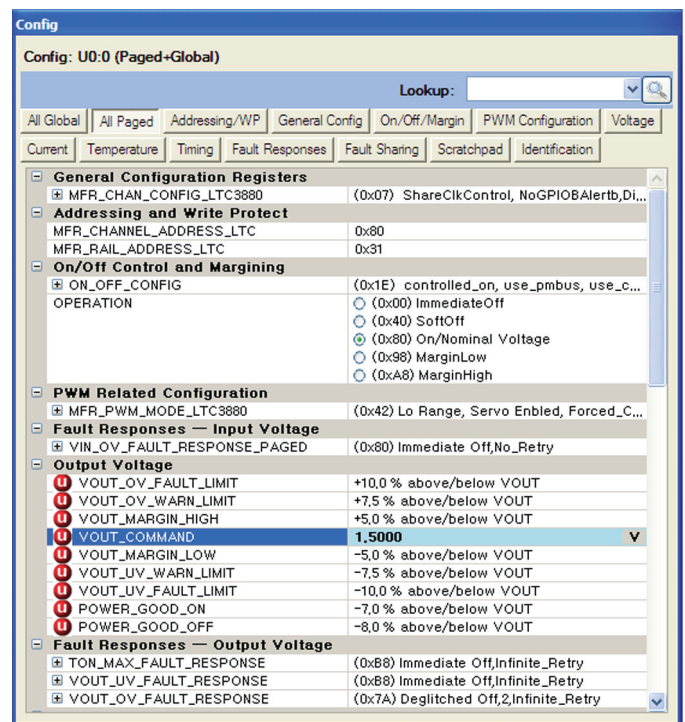

LTpowerPlay QUICK START PROCEDURE

Then, click the “W” (PC to RAM) icon to write these register values to the LTC3880 and the LTC3883. After finishing this step, you will see the output voltage will change to 1.5V.



If the write is successful, you will see the following message:

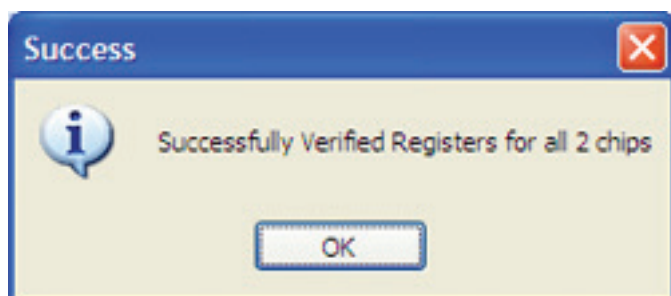

- e. You can save the changes into the NVM. In the tool bar, click “RAM to NVM” button, as following



- f. Save the demo board configuration to a (*.proj) file. Click the Save icon and save the file. Name it whatever you want.

DEMO MANUAL DC2052A

PARTS LIST

ITEM	QTY	REFERENCE	PART DESCRIPTION	MANUFACTURE/PART NUMBER
Required Circuit Components				
1	6	C1, C2, C27, C28, C44, C45	CAP., X5R, 22 μ F, 25V, 10%, 1210	MURATA GRM32ER61E226KE15L
2	2	C3, C40	CAP., X7R, 4.7 μ F, 16V, 10%, 0603	TDK C1608X5R1C475K
3	2	C4, C5	CAP., OS-CON, 330 μ F, 16V, 20%	SANYO, 16SVP330M
4	1	C6	CAP., X7R, 100nF, 25V, 10%, 0603	AVX 06033C104KAT2A
5	3	C21, C29, C47	CAP., X7R, 100nF, 25V, 10%, 0402	AVX 04023D104KAT2A
6	6	C7, C8, C14, C36, C41, C53	CAP., X5R, 1 μ F, 10V, 20%, 0402	AVX 0402ZD105KAT2A
7	2	C38, C39	CAP., X5R, 1 μ F, 10V, 20%, 0603	TAIYO YUDEN EMK107BJ105KA
8	18	C9, C10, C11, C12, C13, C30, C31, C32, C33, C34, C35, C48, C49, C50, C51, C52, C71, C72	CAP., X5R, 100 μ F, 6.3V, 20%, 1210	AVX 12106D107MAT2A
9	6	C16, C17, C18, C19, C20, C74	CAP., POSCAP, 470 μ F, 2.5V	SANYO, 2R5TPE470M9
10	3	C22, C37, C54	CAP., POSCAP, 470 μ F, 2.5V	AVX 0402YD104KAT2A
11	1	C23	CAP., X7R, 1000pF, 25V, 10%, 0603	AVX 06033A102KAT2A
12	3	C24, C26, C55	CAP., X5R, 10nF, 25V, 10%, 0402	AVX 04023C103KAT2A
13	1	C56	CAP., X5R, 100pF, 25V, 10%, 0603	AVX 06033A101JAT2A
14	1	C25	CAP., NPO, 47pF, 25V, 10%, 0603	AVX 06033A470JAT2A
15	1	C42	CAP., X5R, 0.1 μ F, 10V, 20%, 0603	AVX 0603ZC104MAT2A
16	2	C43, C46	CAP., X7R, 0.01 μ F, 16V, 10%, 0402	AVX 0402YC103KAT2A
17	3	D1, D2, D3	DIODE, SCHOTTKY, SOD-323	CENTRAL CMDSH-3TR
18	3	L1, L2, L3	INDUCTOR, SMT POWER IND. 0.3 μ H	COILCRAFT., XAL7070-301ME
19	3	Q1, Q4, Q5	DUAL N-CHANNEL MOSFET 25V	FAIRCHILD FDMS3620S
20	7	Q2, Q3, Q6	TRANS GP SS PNP 40V SOT-416	ON SEMI MMBT3906TT1
21	2	R1, R81	RES., CHIP, 2 Ω , 1%, 0603	YAGEO RC0603FR-072RL
22	3	R2, R4, R6	RES., CHIP, 10k, 1%, 0603	NIC NRC06F1002TRF
23	3	R3, R17, R24	RES., CHIP, 10k, 1%, 0402	VISHAY CRCW040210K0FKED
24	6	R7, R8, R18, R19, R44, R45	RES., CHIP, 2.61k, 1%, 0402	VISHAY CRCW04022K61FKED
25	9	R11, R12, R35, R39, R43, R49, R51, R52, R56	RES., CHIP, 0 Ω , 1%, 0603	VISHAY CRCW06030000Z0ED
26	6	R10, R14, R15, R22, R38, R94	RES., CHIP, 0 Ω , 1%, 0402	VISHAY CRCW04020000Z0ED
27	1	R13	RES., CHIP, 4.53k, 1%, 0603	YAGEO RC0603FR-074K53L
28	2	R25, R26	RES., CHIP, 100 Ω , 1%, 0402	VISHAY CRCW0402100RFKED
29	2	R40, R46	RES., CHIP, 4.99k, 1%, 0402	VISHAY CRCW04024K99FKEA
30	1	U1	IC, LTC3880EUJ, QFN 6mm x 6mm	LINEAR TECH., LTC3880EUJ#0125-1PBF
31	1	U2	IC, LTC3883EUH, QFN 5mm x 5mm	LINEAR TECH., LTC3883EUH#0126-1PBF
Additional Circuit Components				
1	2	C60, C64	CAP., X7R, 4.7 μ F, 16V, 10%, 0603	TDK C1608X5R1C475K
2	1	C59	CAP., X7R, 100nF, 25V, 10%, 0603	AVX 06033C104KAT2A
3	1	C70	CAP., X5R, 1 μ F, 10V, 20%, 0805	AVX 0805ZD105KAT2A
4	4	C61, C62, C65, C67, C68	CAP., X5R, 1 μ F, 10V, 20%, 1206	AVX 1206YD105KAT2A
5	0	C15, C57, C73 (OPT)	CAP., OPTIONAL	

PARTS LIST

ITEM	QTY	REFERENCE	PART DESCRIPTION	MANUFACTURE/PART NUMBER
6	1	C66	CAP., X5R, 2.2μF, 16V, 10%, 0805	AVX 0805YD224KAT2A
7	1	C58	CAP., X5R, 10nF, 25V, 10%, 0603	AVX 06033A103JAT2A
8	1	C63	CAP., X5R, 10uF,25V, 20%,1206	Taiyo Yuden TMK316BJ106ML
9	1	C69	CAP., X5R, 150pF, 25V, 20%, 0603	AVX 06033C151KAT2A
10	1	D4	LED GREEN S-GW TYPE SMD	PANASONIC LN1371SGTRP
11	1	D5	LED RED S-TYPE GULL WING SMD	PANASONIC LN1271RTR
12	3	Q7, Q8, Q9	MOSFET P-CH 20V 0.58A SOT-23	VISHAY, TP0101K-T1-E3
13	1	Q10	MOSFET N-CH 60V 115MA SOT-23	FAIRCHILD, 2N7002K-7-F
14	1	Q11	MOSFET SPEED SRS 30V 30A LFPK	RENESAS, RJK0305DPB-00#J0
15	1	R27	RES., CHIP, 2Ω, 1%, 0603	Yageo RC0603FR-072RL
16	4	R63, R64, R70, R88	RES., CHIP, 10k, 1%, 0603	NIC NRC06F1002TRF
17	1	R5	RESISTOR 0.005Ω 1W 1% 0815	SUSMU RL3270WT-R005-F
18		R9, R16, R23, R28, R29, R30, R31, R32, R33, R34, R36, R37, R41, R42, R47, R48, R53, R54, R59, R61, R66, R73, R75, R95	RES., OPTIONAL	
19	2	R20, R50	RES., CHIP, 16.2k, 1%, 0402	VISHAY CRCW040216K2FKED
20	1	R21	RES., CHIP, 17.4k, 1%, 0402	VISHAY CRCW040217K4FKEA
21	1	R55	RES., CHIP, 20.5k, 1%, 0402	VISHAY CRCW040220K5FKED
22	11	R11, R12, R35, R39, R43, R49, R51, R52, R56	RES., CHIP, 0Ω, 1%, 0603	VISHAY CRCW06030000Z0ED
23	4	R60, R62, R65, R67	RES., CHIP, 0Ω, 1%, 0603	VISHAY CRCW06030000Z0ED
24	2	R76, R77	RES., CHIP, 4.99k, 1%, 0603	VISHAY CRCW06034K99FKEA
25	2	R68, R69	RES., CHIP, 15.8k, 1%, 0603	ROHM, MCR03EZPFX1582
26	2	R71, R90	RES., CHIP, 10Ω, 1%, 0603	NIC NRC06F10R0TRF
27	1	R72	RES., CHIP, 200Ω, 1%, 0603	NIC NRC06F2000TRF
28	1	R74	RES., CHIP, 127Ω, 1%, 0603	VISHAY CRCW0603127RFKEA
29	3	R78, R79, R80	RES., CHIP, 100k, 1%, 0603	NIC NRC06F1003TRF
30	1	R82	RES., CHIP, 1M, 1%, 0603	NIC NRC06f1004TRF
31	1	R83	RES., CHIP, 154k, 1%, 0603	VISHAY CRCW0603154KFKEA
32	2	R84, R86	RES., CHIP, 20k, 1%, 0603	NIC NRC06F2002TRF
33	1	R85	RES., CHIP, 3.3Ω, 1%, 0603	VISHAY CRCW06033R30JNEA
34	1	R87	RES., CHIP, 681k, 1%, 0603	VISHAY CRCW0603681KFKEA
35	1	R89	RES., CHIP, 82.5Ω, 1%, 0603	VISHAY CRCW060382R5FKEA
36	1	R91	RES., CHIP, 0.01Ω, 1%, 2010	VISHAY, WSL2010R0100FEA
37	1	R92	TRIMMING POTENTIOMETER, 5k	BOURNS, 3386P-1-502LF
38	1	U3	IC, 24LC025-I/ST, SOIC	MICROCHIP, 24LC025-I/ST
39	2	U4, U6	IC, LT1129CS8-5, S8 PACKAGE	LINEAR TECH, LT1129CS8-5
40	1	U5	IC, LT1129CS8-3.3 S8 PACKAGE	LINEAR TECH. LT1129CS8-3.3
41	1	U7	IC., LTC6992-1, S6-TSOT	LINEAR TECH. LTC6992CS6-1
42	1	U8	IC., LT1803IS5, S5-TSOT	LINEAR TECH. LT1803IS5

DEMO MANUAL DC2052A

PARTS LIST

ITEM	QTY	REFERENCE	PART DESCRIPTION	MANUFACTURE/PART NUMBER
Hardware				
1	15	E1-E5, E7, E8, E10, E12-E14, E18-E24	TESTPOINT, TURRET, 0.062"	MILL-MAX, 2308-2-00-80-00-00-07-0
2	4	J1-J4	STUD, TEST PIN	PEM KFH-032-10
3	8	J1-J4 (x2)	NUT, BRASS 10-32	ANY #10-32
4	4	J1-J4	RING, LUG #10	KEYSTONE, 8205, #10
5	4	J1-J4	WASHER, TIN PLATED BRASS	ANY #10
6	1	SW1	CONNECTOR, SUB MINIATURE SLIDE SWITCHES	C&K., JS202011CQN
7	4	JP1-JP4	HEADER 3 PIN 0.079 SINGLE ROW	SAMTEC, TMM103-02-L-S
8	4	JP1-JP4	SHUNT	SAMTEC, 2SN-BK-G
9	1	J6	PIN HEADER 20 DUAL ROW RA (M)	MILL MAX 802-40-020-20-0001
10	1	J7	CONN HEADER 12POS 2MM STR DL PCB	FCI 98414-G06-12ULF
11	1	J8	CONN SOCKET 20 DUAL ROW RA (F)	MILL MAX 803-93-020-20-001
12	2	J9, J10	CONN, BNC, 5 PINS	CONNEX, 112404
13	4	MTH1-MTH4	STAND-OFF, NYLON 0.50" tall	KEYSTONE, 8833(SNAP ON)
14	2		STENCIL (TOP & BOTTOM)	STENCIL DC2052AT

SCHEMATIC DIAGRAM

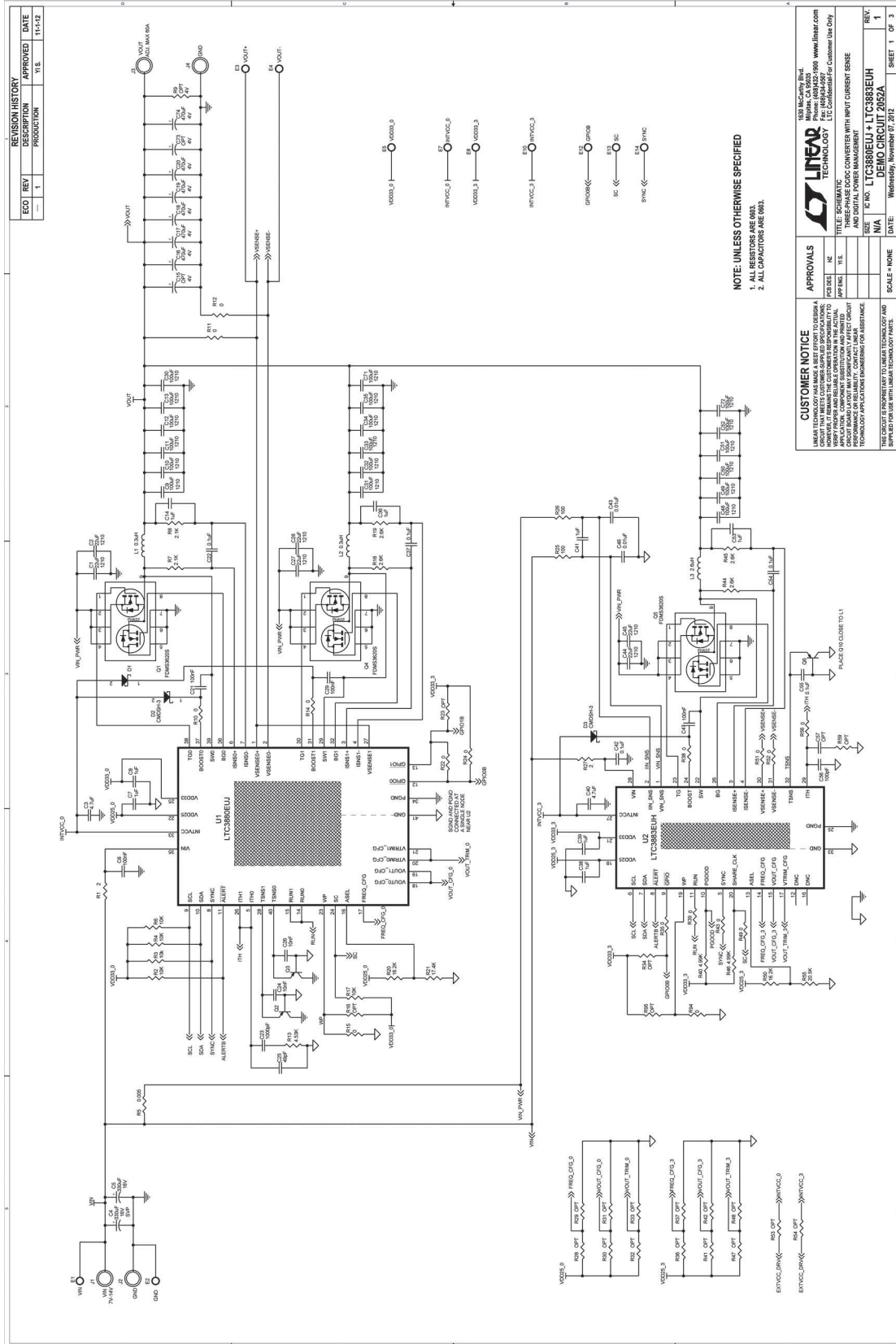

DEMO MANUAL DC2052A

SCHEMATIC DIAGRAM

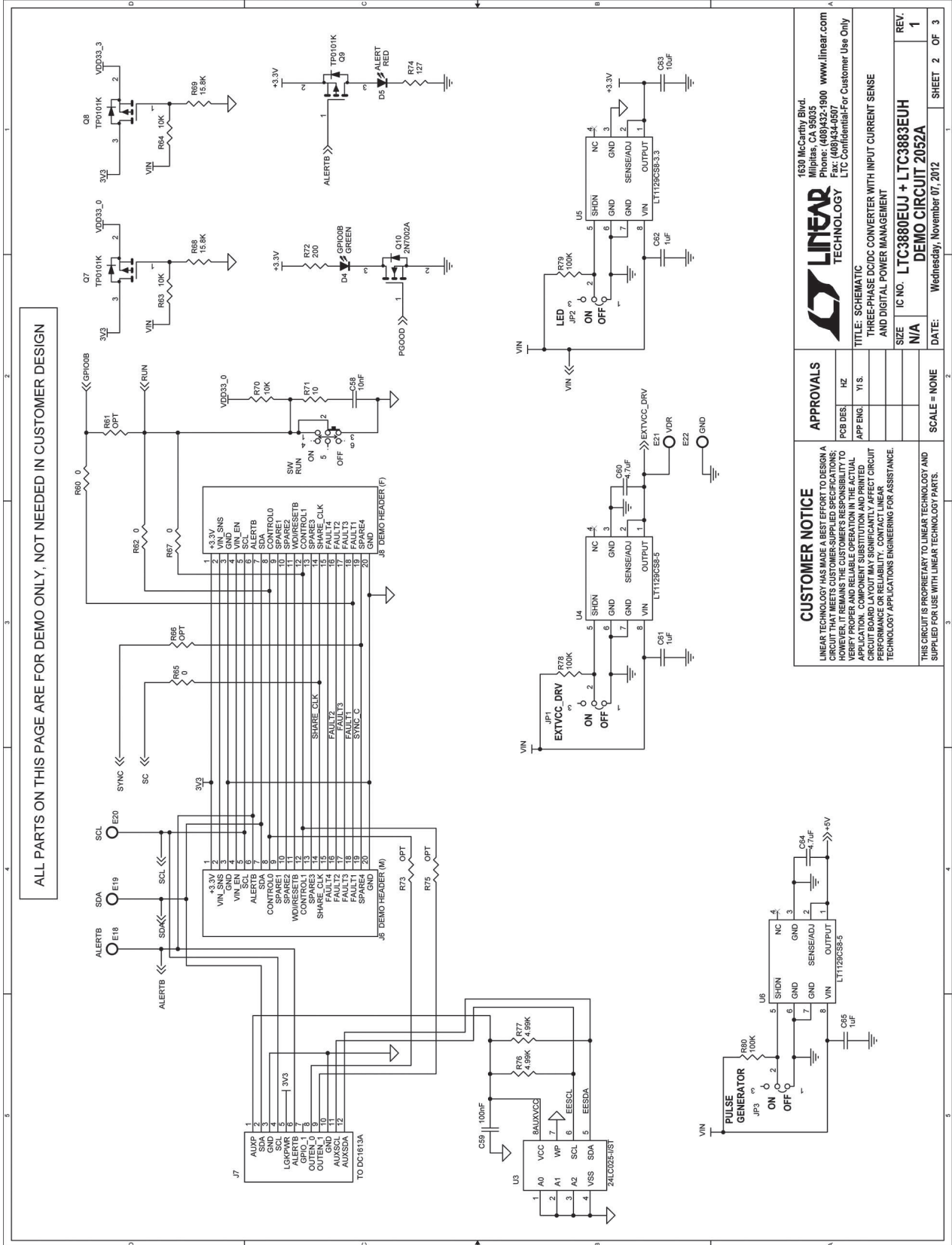

<p>CUSTOMER NOTICE</p> <p>LINEAR TECHNOLOGY HAS MADE A BEST EFFORT TO DESIGN A CIRCUIT THAT MEETS CUSTOMER-SUPPLIED SPECIFICATIONS; HOWEVER, IT REMAINS THE CUSTOMER'S RESPONSIBILITY TO VERIFY THAT THE CIRCUIT MEETS ALL CUSTOMER-SUPPLIED APPLICATION, COMPONENT SUBSTITUTION AND PRINTED CIRCUIT BOARD LAYOUT MAY SIGNIFICANTLY AFFECT CIRCUIT PERFORMANCE OR RELIABILITY. CONTACT LINEAR TECHNOLOGY APPLICATIONS ENGINEERING FOR ASSISTANCE.</p>	<p>APPROVALS</p> <table border="1" style="width: 100%; border-collapse: collapse;"> <tr> <th>POB DES</th> <th>HZ</th> </tr> <tr> <td> </td> <td> </td> </tr> <tr> <th>APP ENG</th> <th>Y1.S.</th> </tr> <tr> <td> </td> <td> </td> </tr> </table>	POB DES	HZ			APP ENG	Y1.S.			<p style="text-align: center;">LINEAR TECHNOLOGY</p> <p style="text-align: center;">1630 McCarthy Blvd. Milpitas, CA 95035 Phone: (408)432-1900 www.linear.com Fax: (408)434-0507 LTC Confidential-For Customer Use Only</p> <p style="text-align: center;">SCHEMATIC</p> <p style="text-align: center;">THREE-PHASE DC/DC CONVERTER WITH INPUT CURRENT SENSE AND DIGITAL POWER MANAGEMENT</p> <p style="text-align: center;">IC NO. LTC3880EUJ + LTC3883EUH</p> <p style="text-align: center;">REV. 1</p> <p style="text-align: center;">DATE: Wednesday, November 07, 2012</p> <p style="text-align: center;">SHEET 2 OF 3</p>
POB DES	HZ									
APP ENG	Y1.S.									
<p>THIS CIRCUIT IS PROPRIETARY TO LINEAR TECHNOLOGY AND SUPPLIED FOR USE WITH LINEAR TECHNOLOGY PARTS.</p>										

SCHEMATIC DIAGRAM

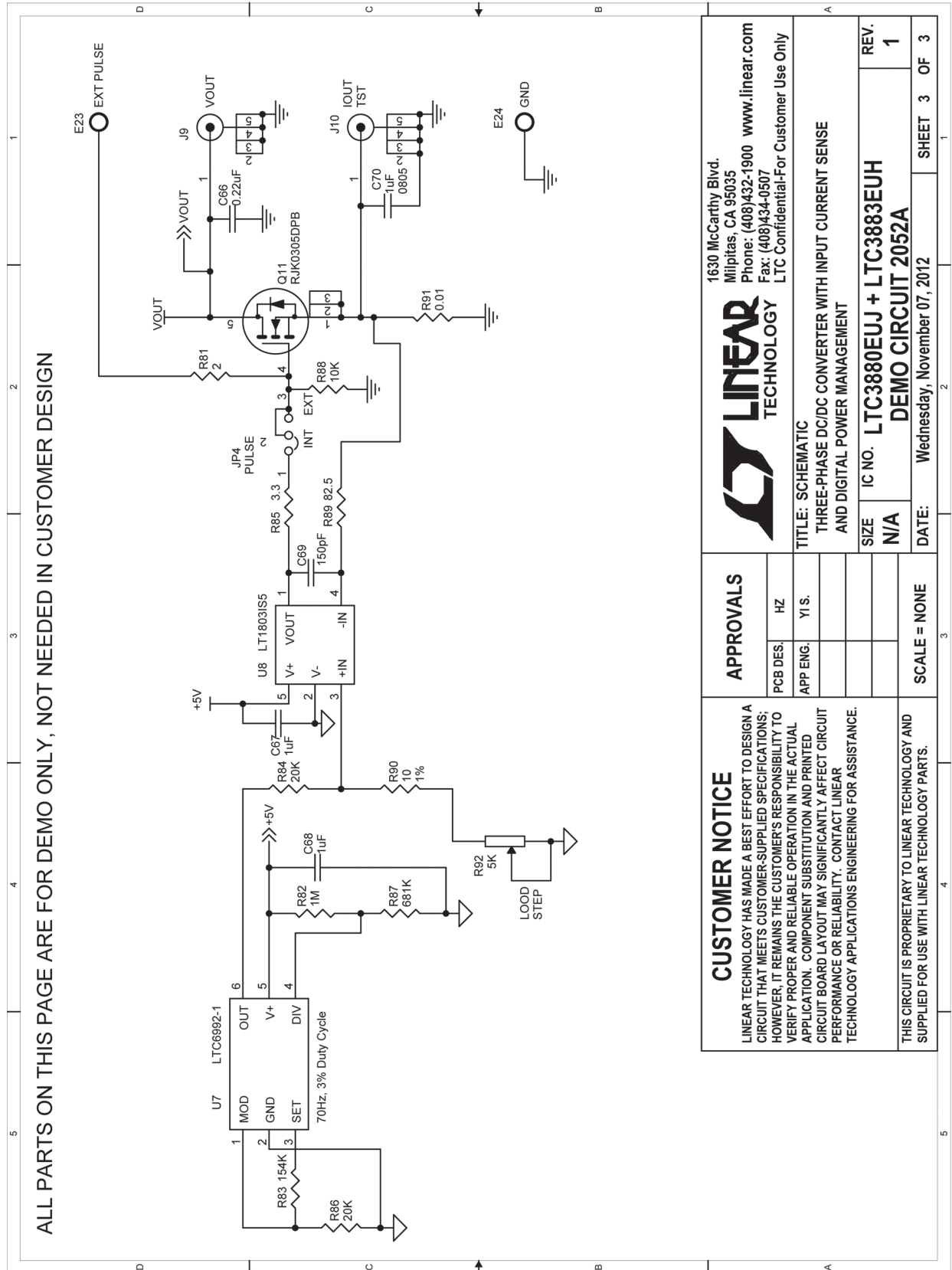

dc2052af

DEMO MANUAL DC2052A

DEMONSTRATION BOARD IMPORTANT NOTICE

Linear Technology Corporation (LTC) provides the enclosed product(s) under the following **AS IS** conditions:

This demonstration board (DEMO BOARD) kit being sold or provided by Linear Technology is intended for use for **ENGINEERING DEVELOPMENT OR EVALUATION PURPOSES ONLY** and is not provided by LTC for commercial use. As such, the DEMO BOARD herein may not be complete in terms of required design-, marketing-, and/or manufacturing-related protective considerations, including but not limited to product safety measures typically found in finished commercial goods. As a prototype, this product does not fall within the scope of the European Union directive on electromagnetic compatibility and therefore may or may not meet the technical requirements of the directive, or other regulations.

If this evaluation kit does not meet the specifications recited in the DEMO BOARD manual the kit may be returned within 30 days from the date of delivery for a full refund. **THE FOREGOING WARRANTY IS THE EXCLUSIVE WARRANTY MADE BY THE SELLER TO BUYER AND IS IN LIEU OF ALL OTHER WARRANTIES, EXPRESSED, IMPLIED, OR STATUTORY, INCLUDING ANY WARRANTY OF MERCHANTABILITY OR FITNESS FOR ANY PARTICULAR PURPOSE. EXCEPT TO THE EXTENT OF THIS INDEMNITY, NEITHER PARTY SHALL BE LIABLE TO THE OTHER FOR ANY INDIRECT, SPECIAL, INCIDENTAL, OR CONSEQUENTIAL DAMAGES.**

The user assumes all responsibility and liability for proper and safe handling of the goods. Further, the user releases LTC from all claims arising from the handling or use of the goods. Due to the open construction of the product, it is the user's responsibility to take any and all appropriate precautions with regard to electrostatic discharge. Also be aware that the products herein may not be regulatory compliant or agency certified (FCC, UL, CE, etc.).

No License is granted under any patent right or other intellectual property whatsoever. **LTC assumes no liability for applications assistance, customer product design, software performance, or infringement of patents or any other intellectual property rights of any kind.**

LTC currently services a variety of customers for products around the world, and therefore this transaction **is not exclusive**.

Please read the DEMO BOARD manual prior to handling the product. Persons handling this product must have electronics training and observe good laboratory practice standards. **Common sense is encouraged.**

This notice contains important safety information about temperatures and voltages. For further safety concerns, please contact a LTC application engineer.

Mailing Address:

Linear Technology
1630 McCarthy Blvd.
Milpitas, CA 95035

Copyright © 2004, Linear Technology Corporation