



Chipsmall Limited consists of a professional team with an average of over 10 year of expertise in the distribution of electronic components. Based in Hongkong, we have already established firm and mutual-benefit business relationships with customers from,Europe,America and south Asia,supplying obsolete and hard-to-find components to meet their specific needs.

With the principle of “Quality Parts,Customers Priority,Honest Operation,and Considerate Service”,our business mainly focus on the distribution of electronic components. Line cards we deal with include Microchip,ALPS,ROHM,Xilinx,Pulse,ON,Everlight and Freescale. Main products comprise IC,Modules,Potentiometer,IC Socket,Relay,Connector.Our parts cover such applications as commercial,industrial, and automotives areas.

We are looking forward to setting up business relationship with you and hope to provide you with the best service and solution. Let us make a better world for our industry!



Contact us

Tel: +86-755-8981 8866 Fax: +86-755-8427 6832

Email & Skype: info@chipsmall.com Web: www.chipsmall.com

Address: A1208, Overseas Decoration Building, #122 Zhenhua RD., Futian, Shenzhen, China



LTC3265EDHC

Low Noise Dual Supply with Boost and Inverting Charge Pumps

DESCRIPTION

Demonstration Circuit 2235A has boost and inverting charge pumps each with a low noise LDO post regulator featuring the **LTC®3265EDHC**. The LTC3265 operates with an input voltage from 4.5V to 16V for the boost charge pump and from 4.5V to 32V for the inverting charge pump. The demo board provides selectable LDO± output set magnitudes of 5V, 15V, and 24V for each polarity. The demo board also provides the means to select between low power Burst Mode® operation or low noise constant-frequency

mode operation, plus select an operating frequency of 500kHz, 200kHz, or 50kHz.

The LTC3265 data sheet gives a complete description of the device, operation and application information. The data sheet must be read in conjunction with this demo manual.

Design files for this circuit board are available at <http://www.linear.com/demo/DC2235A>

LT, LT, LTC, LTM, Linear Technology, the Linear logo and Burst Mode are registered trademarks of Linear Technology Corporation. All other trademarks are the property of their respective owners.

PERFORMANCE SUMMARY

Specifications are at $T_A = 25^\circ\text{C}$

SYMBOL	PARAMETER	CONDITIONS	MIN	TYP	MAX	UNITS
V_{IN_P}	V_{IN_P} Input Voltage Range		4.5		16	V
V_{IN_N}	V_{IN_N} Input Voltage Range		4.5		32	V
V_{LDO^+}	LDO+ Output Voltage	$V_{IN_P} \cdot 2 \geq \text{LDO}^+ \text{ Set Point} + 0.8\text{V}$	1.2		32	V
V_{LDO^-}	LDO- Output Voltage	$V_{IN_N} \leq \text{LDO}^- \text{ Set Point} - 0.5\text{V}$	-32		-1.2	V
V_{OUT^+}	V_{OUT^+} Output Voltage Range	MODE = 0V (Const. Freq.) MODE \geq 2V (Burst)		$V_{IN_P} \cdot 2$ $0.94 \cdot V_{IN_P} \cdot 2$		V V
V_{OUT^-}	V_{OUT^-} Output Voltage Range	MODE = 0V (Const. Freq.) MODE \geq 2V (Burst)		$-V_{IN_N}$ $-0.94 \cdot V_{IN_N}$		V V

BOARD PHOTO

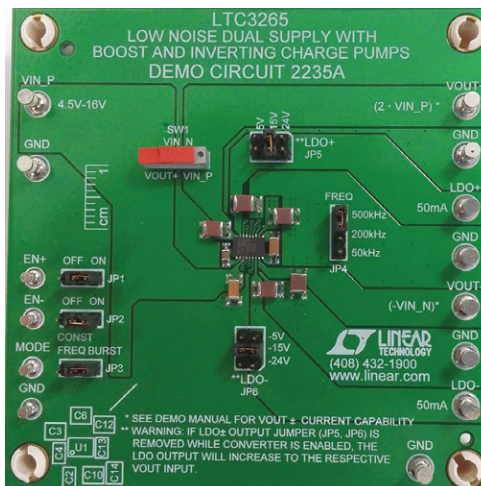

TYPICAL APPLICATIONS

Low Noise $\pm 15V$ Outputs from a Single 12V Input

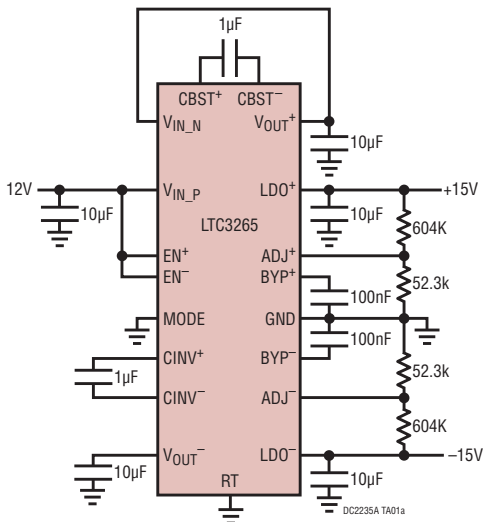

LDO Rejection of V_{OUT}^{\pm} Ripple

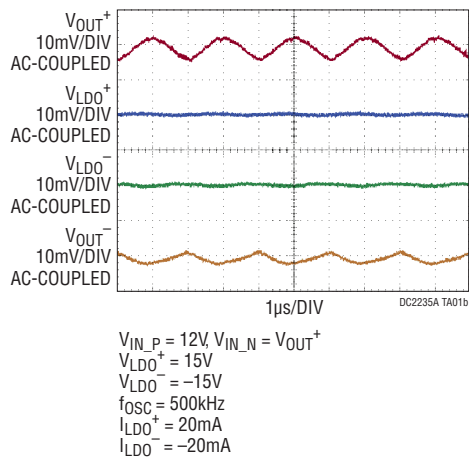

QUICK START PROCEDURE

Refer to Figure 1 for the proper measurement equipment setup and jumper settings and follow the procedure below.

NOTE: When measuring the input or output voltage ripple, care must be taken to avoid a long ground lead on the oscilloscope probe. Measure the input or output voltage ripple by touching the probe tip directly across the V_{IN} or V_{OUT} and GND terminals. See Figure 2 for proper scope probe technique.

1. Make sure the jumper settings are as follows:

- JP1:** EN^+ is on the ON position
- JP2:** EN^- is on the ON position
- JP3:** MODE is in the Burst position
- JP4:** FREQ is on the 500kHz position
- JP5:** LDO^+ is set to 15V setting
- JP6:** LDO^- is set to -15V setting

2. Set SW1 to the V_{OUT}^+ position.
3. Set PS1 to 12V.
4. Slowly increase load on LDO^- to -50mA and observe how output ripple on V_{OUT}^- changes and how burst frequency increases. When the load is large enough, the charge pump will run constant-frequency.

5. Slowly increase the load on LDO^+ to 50mA and observe the output ripple and the output voltage on LDO^+ .
6. Set the LDO^+ load and the LDO^- load to 0mA and turn off PS1.
7. Set SW1 to the V_{IN_P} position.
8. Set JP5 LDO^+ jumper to 5V position and JP6 LDO^- to the -5V position.

Note: It is recommended to remove power or disable the respective regulators prior to changing the positions of the LDO^{\pm} output jumpers (JP5, JP6).

9. Repeat steps 3 through 6.
10. Set JP5 LDO^+ jumper to 24V position and JP6 LDO^- to the -24V position.
11. Set SW1 to the V_{OUT}^+ position
12. Turn on and set PS1 to 15V.
13. Repeat steps 4 through 6.
14. Return JP5 LDO^+ jumper to 15V position and JP5 LDO^- to the -15V position.
15. Turn on and set PS1 to 12V.

QUICK START PROCEDURE

16. Slowly increase the load on V_{OUT}^+ to 100mA and observe the output ripple and output voltage on V_{OUT}^+ .
17. Set the load on V_{OUT}^+ to 0mA.
18. Slowly increase the load on V_{OUT}^- to -100mA and observe the output ripple and output voltage on V_{OUT}^- .
19. Set the load on V_{OUT}^- to 0mA.
20. Change JP3 MODE jumper from Burst Mode operation to the constant-frequency mode and repeat steps 16 to 19.
21. Change JP4 FREQ jumper from 500kHz to 200kHz then slowly increase the load on V_{OUT}^+ from 0mA to 50mA and observe the output ripple and output voltage on V_{OUT}^+ .
22. Set the load on V_{OUT}^+ to 0mA.
23. Slowly increase the load on V_{OUT}^- to -50mA and observe the output ripple and output voltage on V_{OUT}^- .
24. Set the load on V_{OUT}^- to 0mA.
25. Change JP4 FREQ jumper from 200kHz to 50kHz. Slowly increase the load on V_{OUT}^+ from 0mA to 10mA and observe the output ripple and output voltage on V_{OUT}^+ .
26. Set the load on V_{OUT}^+ to 0mA.
27. Slowly increase the load on V_{OUT}^- to -10mA and observe the output ripple and output voltage on V_{OUT}^- .
28. Set the load on V_{OUT}^- to 0mA.
29. Turn off the loads and supply when done.

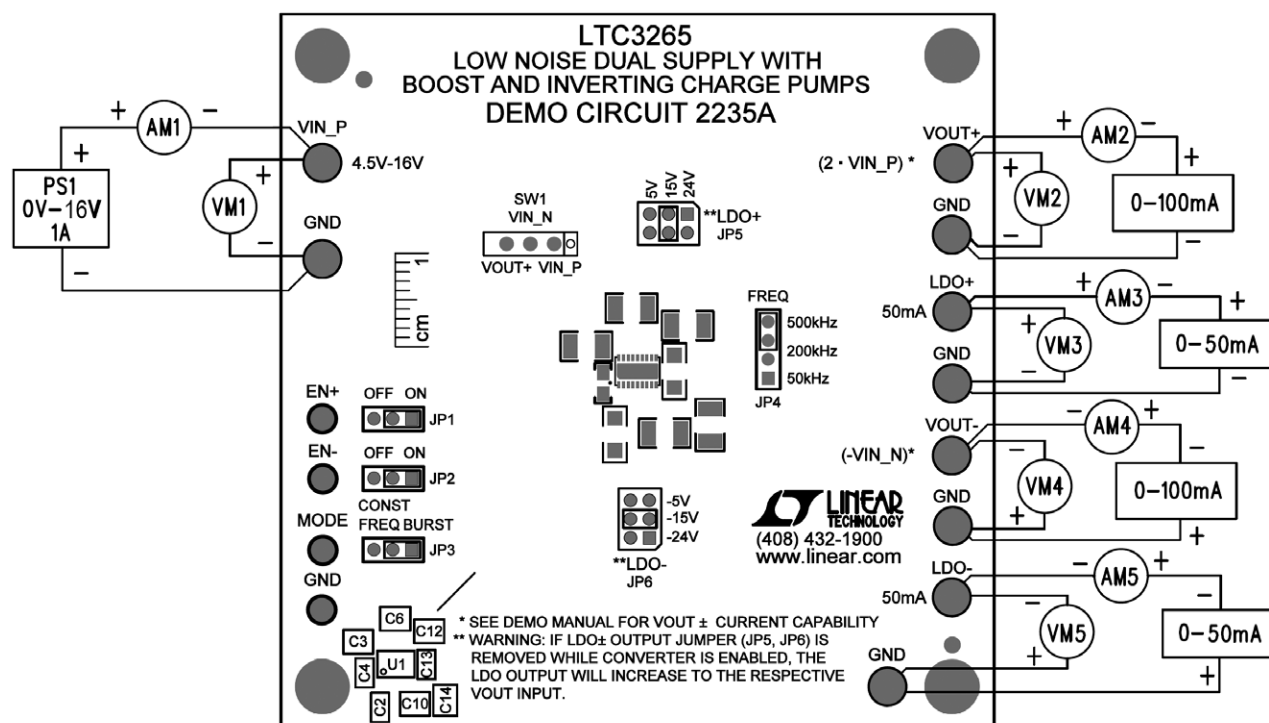

Figure 1. Proper Measurement Equipment Setup for DC2235A

QUICK START PROCEDURE

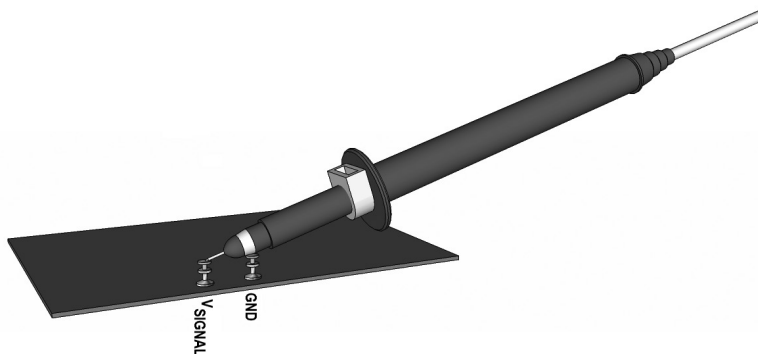

Figure 2. Measuring Input or Output Ripple

APPLICATIONS INFORMATION

Figure 3 illustrates the voltage loss from the ideal boost charge pump output voltage of $2 \cdot V_{IN_P}$ to the measured V_{OUT}^+ voltage. Figure 4 illustrates the voltage loss from

the ideal inverting charge pump output voltage of $-V_{IN_N}$ to the measured V_{OUT}^- voltage.

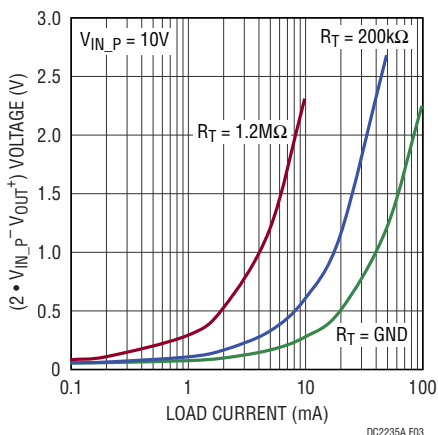

Figure 3. V_{OUT}^+ Voltage Loss vs Output Current (Constant-Frequency Mode)

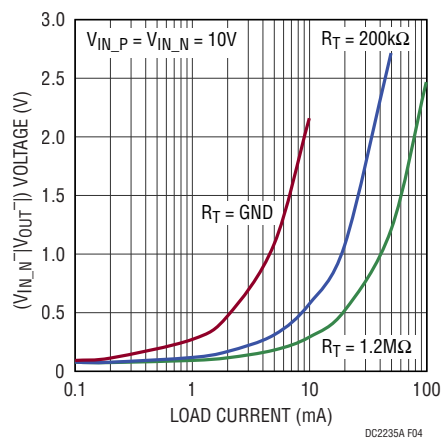

Figure 4. V_{OUT}^- Voltage Loss vs Output Current (Constant-Frequency Mode)

APPLICATIONS INFORMATION

Figures 5 and 6 are CISPR radiated and conducted emissions respectively. The data were collected in a GTEM chamber and using a CISPR25 LISN for conducted emissions. The EMI tests were conducted using a 12V input on V_{IN_P} , V_{OUT}^+ connected to V_{IN_N} via SW1 of the demo board, and a 600Ω resistor load between LDO⁺ and

LDO⁻ in constant-frequency mode with a 500kHz oscillator frequency. Linear Technology has made every effort to provide useful and accurate EMI data, but it remains the responsibility of the customer to ensure product compliance with applicable rules and regulations.

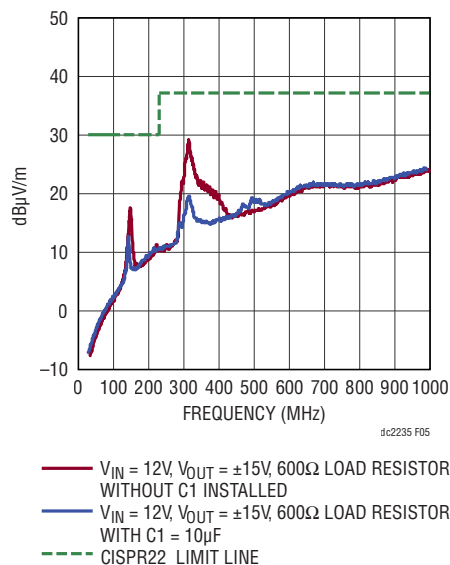

Figure 5. CISPR22 Radiated Emissions

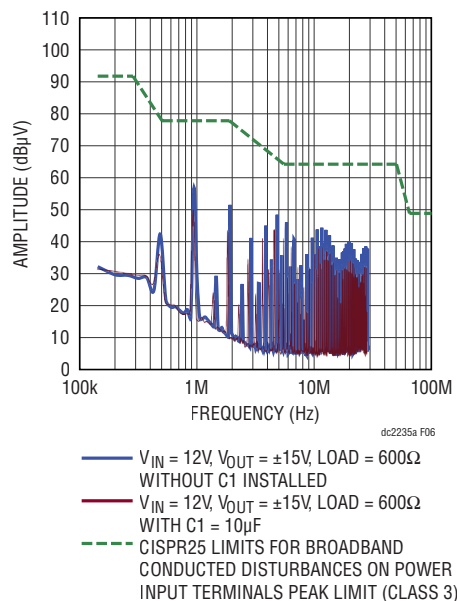

Figure 6. CISPR25 Conducted Emissions

DEMO MANUAL DC2235A

PARTS LIST

ITEM	QTY	REFERENCE	PART DESCRIPTION	MANUFACTURER/PART NUMBER
Required Circuit Components				
1	1	C2	CAP, CHIP, X7R, 10 μ F, \pm 10%, 25V, 1206	WURTH ELEKTRONIK, 885012208069
2	5	C3, C6, C10, C12, C14	CAP, CHIP, X7S, 10 μ F, \pm 10%, 50V, 1210	TDK, C3225X7S1H106K250AB
3	1	C4	CAP, CHIP, X7R, 1 μ F, \pm 10%, 25V, 0805	TDK, C2012X7R1E105K125AB
4	1	C13	CAP, CHIP, X7R, 1 μ F, \pm 10%, 50V, 1206	TDK, C3216X7R1H105K160AB
5	2	R3, R9	RES 604k Ω 1/16W 1% 0402 SMD	VISHAY, CRCW0402604KFKED
6	2	R11, R12	RES 52.3k Ω 1/16W 1% 0402 SMD	VISHAY, CRCW0402523K3FKED
7	1	U1	LOW NOISE DUAL SUPPLY WITH BOOST AND INVERTING CHARGE PUMPS	LINEAR TECH., LTC3265EDHC#PBF
Additional Demo Board Circuit Components				
8	1	C1	CAP, CHIP, X7R, 10 μ F, \pm 10%, 25V, 1206	WURTH, 885012208069
9	0	C5, C7, C9 (OPT)	CAP, CHIP, 25V, 0603	
10	2	C8, C11	CAP, CHIP, X7R, .1 μ F, \pm 10%, 16V, 0402	MURATA, GRM155R71C104KA88D
11	2	C15, C16	CAP, CHIP, NPO, 10pF, \pm 5%, 50V, 0402	AVX, 04025A100JAT2A
12	3	R1, R6, R13	RES 1.0M Ω 1/16W 5% 0402 SMD	VISHAY, CRCW04021M00JNED
13	2	R2, R8	RES 1.0M Ω 1/16W 1% 0402 SMD	VISHAY, CRCW04021M00FKED
14	2	R4, R10	RES 165k Ω 1/16W 1% 0402 SMD	VISHAY, CRCW0402165KFKED
15	3	R5, R7, R14	RES 4.7k Ω 1/16W 5% 0402 SMD	VISHAY, CRCW04024K70JNED
16	1	R15	RES 909k Ω 1/16W 1% 0402 SMD	VISHAY, CRCW0402909KFKED
17	1	R16	RES 200k Ω 1/16W 1% 0402 SMD	VISHAY, CRCW0402200KFKED
Hardware				
18	3	JP1, JP2, JP3	HEADER, 3-PIN 1 ROW 0.079CC	SULLIN, NRPNO31PAEN-RC
19	1	JP4	HEADER, 4-PIN 1 ROW 0.079CC	SULLIN, NRPNO41PAEN-RC
20	2	JP5, JP6	HEADER, 2 \times 3 PINS, 2mm	SULLIN, NRPNO32PAEN-RC
21	6	JP1-JP6	SHUNT, 2mm	SAMTEC, 2SN-BK-G
22	10	E1, E2, E7-E14	TP, TURRET, 0.094", PBF	MILL-MAX, 2501-2-00-80-00-00-07-0
23	4	E3-E6	TURRET, 0.061" DIA	MILL-MAX, 2308-2-00-80-00-00-07-0
24	4	MH1-MH4	STAND-OFF, NYLON 0.375" TALL	KEYSTONE, 8832 (SNAP ON)
25	1	SW1	10mm \times 2.5mm, SLIDE SWITCH, THT	WURTH ELEKTRONIK, 450301014042

REVISION HISTORY				
ECO	REV	DESCRIPTION	APPROVED	DATE
-	3	PRODUCTION FAB	M. MERCHANT	05 - 28 - 15

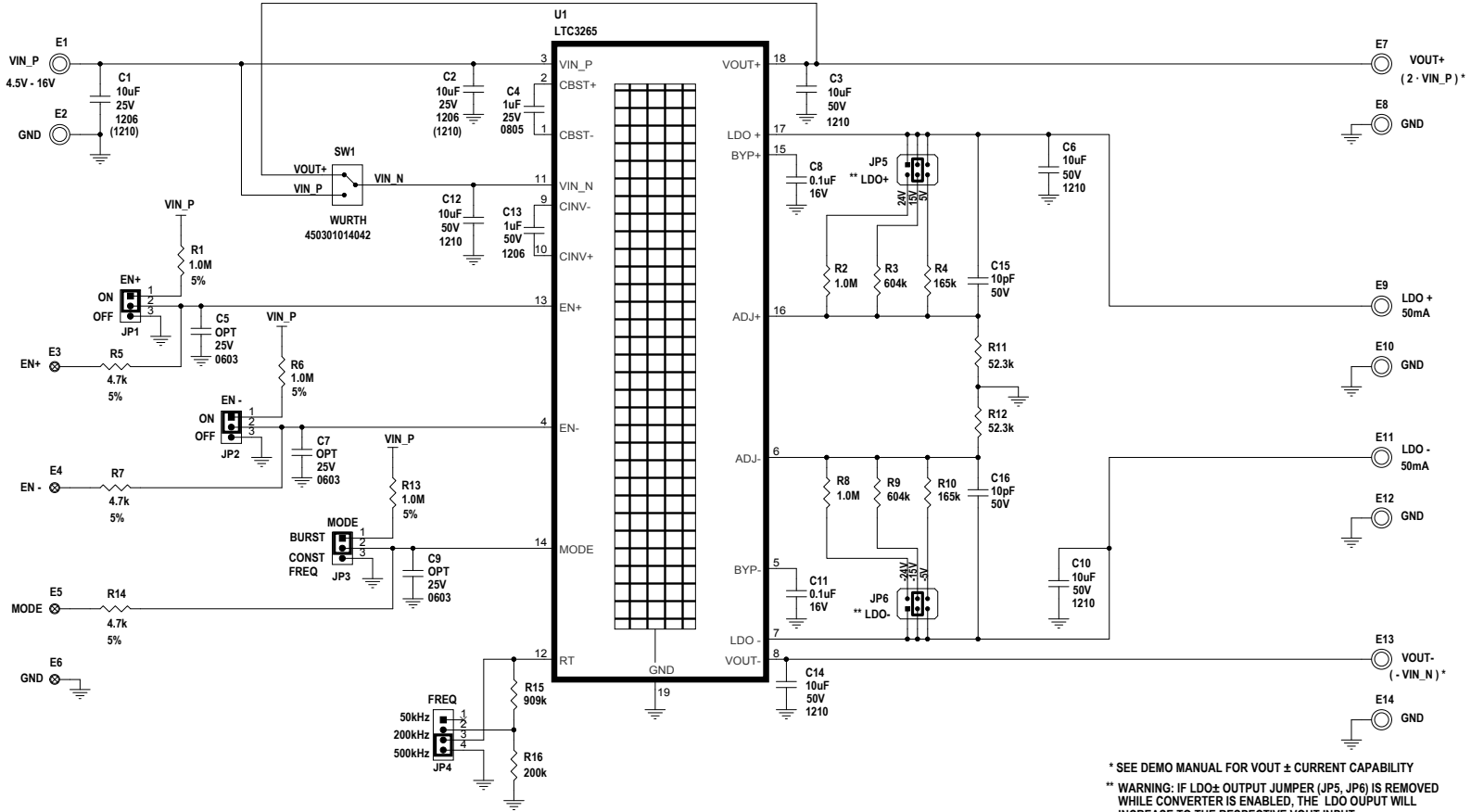

* SEE DEMO MANUAL FOR VOUT ± CURRENT CAPABILITY
 ** WARNING: IF LDO± OUTPUT JUMPER (JP5, JP6) IS REMOVED WHILE CONVERTER IS ENABLED, THE LDO OUTPUT WILL INCREASE TO THE RESPECTIVE VOUT INPUT.

NOTE: UNLESS OTHERWISE SPECIFIED

1. ALL RESISTORS ARE 0402, 1%, 1/16W
ALL CAPACITORS ARE 0402, 10%
2. INSTALL SHUNTS AS SHOWN.

CUSTOMER NOTICE		APPROVALS		 1630 McCarthy Blvd. Milpitas, CA 95035 Phone: (408)432-1900 www.linear.com Fax: (408)434-6507 LTC Confidential-For Customer Use Only	
LINEAR TECHNOLOGY HAS MADE A BEST EFFORT TO DESIGN A CIRCUIT THAT MEETS CUSTOMER-SUPPLIED SPECIFICATIONS; HOWEVER, IT REMAINS THE CUSTOMER'S RESPONSIBILITY TO VERIFY PROPER AND RELIABLE OPERATION IN THE ACTUAL APPLICATION. COMPONENT SUBSTITUTION AND PRINTED CIRCUIT BOARD LAYOUT MAY SIGNIFICANTLY AFFECT CIRCUIT PERFORMANCE OR RELIABILITY. CONTACT LINEAR TECHNOLOGY APPLICATIONS ENGINEERING FOR ASSISTANCE.		PCB DES.	NC	TITLE: SCHEMATIC LOW NOISE DUAL SUPPLY WITH BOOST AND INVERTING CHARGE PUMPS	
		APP ENG.	MARTY M.	SIZE	N/A
				IC NO.	LTC3265EDHC
				DEMO CIRCUIT	2235A
THIS CIRCUIT IS PROPRIETARY TO LINEAR TECHNOLOGY AND SUPPLIED FOR USE WITH LINEAR TECHNOLOGY PARTS.		SCALE	NONE	DATE:	05 - 28 - 15
					REV. 3
					SHEET 1 OF 1

DEMO MANUAL DC2235A

DEMONSTRATION BOARD IMPORTANT NOTICE

Linear Technology Corporation (LTC) provides the enclosed product(s) under the following **AS IS** conditions:

This demonstration board (DEMO BOARD) kit being sold or provided by Linear Technology is intended for use for **ENGINEERING DEVELOPMENT OR EVALUATION PURPOSES ONLY** and is not provided by LTC for commercial use. As such, the DEMO BOARD herein may not be complete in terms of required design-, marketing-, and/or manufacturing-related protective considerations, including but not limited to product safety measures typically found in finished commercial goods. As a prototype, this product does not fall within the scope of the European Union directive on electromagnetic compatibility and therefore may or may not meet the technical requirements of the directive, or other regulations.

If this evaluation kit does not meet the specifications recited in the DEMO BOARD manual the kit may be returned within 30 days from the date of delivery for a full refund. **THE FOREGOING WARRANTY IS THE EXCLUSIVE WARRANTY MADE BY THE SELLER TO BUYER AND IS IN LIEU OF ALL OTHER WARRANTIES, EXPRESSED, IMPLIED, OR STATUTORY, INCLUDING ANY WARRANTY OF MERCHANTABILITY OR FITNESS FOR ANY PARTICULAR PURPOSE. EXCEPT TO THE EXTENT OF THIS INDEMNITY, NEITHER PARTY SHALL BE LIABLE TO THE OTHER FOR ANY INDIRECT, SPECIAL, INCIDENTAL, OR CONSEQUENTIAL DAMAGES.**

The user assumes all responsibility and liability for proper and safe handling of the goods. Further, the user releases LTC from all claims arising from the handling or use of the goods. Due to the open construction of the product, it is the user's responsibility to take any and all appropriate precautions with regard to electrostatic discharge. Also be aware that the products herein may not be regulatory compliant or agency certified (FCC, UL, CE, etc.).

No License is granted under any patent right or other intellectual property whatsoever. **LTC assumes no liability for applications assistance, customer product design, software performance, or infringement of patents or any other intellectual property rights of any kind.**

LTC currently services a variety of customers for products around the world, and therefore this transaction **is not exclusive**.

Please read the DEMO BOARD manual prior to handling the product. Persons handling this product must have electronics training and observe good laboratory practice standards. **Common sense is encouraged.**

This notice contains important safety information about temperatures and voltages. For further safety concerns, please contact a LTC application engineer.

Mailing Address:

Linear Technology
1630 McCarthy Blvd.
Milpitas, CA 95035

Copyright © 2004, Linear Technology Corporation