



Chipsmall Limited consists of a professional team with an average of over 10 year of expertise in the distribution of electronic components. Based in Hongkong, we have already established firm and mutual-benefit business relationships with customers from,Europe,America and south Asia,supplying obsolete and hard-to-find components to meet their specific needs.

With the principle of "Quality Parts,Customers Priority,Honest Operation,and Considerate Service",our business mainly focus on the distribution of electronic components. Line cards we deal with include Microchip,ALPS,ROHM,Xilinx,Pulse,ON,Everlight and Freescale. Main products comprise IC,Modules,Potentiometer,IC Socket,Relay,Connector.Our parts cover such applications as commercial,industrial, and automotives areas.

We are looking forward to setting up business relationship with you and hope to provide you with the best service and solution. Let us make a better world for our industry!



Contact us

Tel: +86-755-8981 8866 Fax: +86-755-8427 6832

Email & Skype: info@chipsmall.com Web: www.chipsmall.com

Address: A1208, Overseas Decoration Building, #122 Zhenhua RD., Futian, Shenzhen, China



LT8705A

80V V_{IN} and V_{OUT} Synchronous 4-Switch Buck-Boost DC/DC Controller

DESCRIPTION

Demonstration circuit 2285A features two high power high performance buck-boost LT[®]8705A converters operating in master-slave configuration. The circuit can operate with input voltages above, below or equal to the output voltage. The demo board input range is 36V to 75V. The output is optimized for 48V at 18A, with the output current limit set at 20A. The circuit will operate with lower input voltage than 36V if load current is reduced.

The LT8705A controller has integrated input current, input voltage, output current and output voltage regulators. The one regulator that wants to decrease current gets control over the compensation pin V_C . The inductor current is controlled by the V_C signal that is fed into a current comparator together with a ramp compensation signal.

While the current mode control limits the inductor both in normal and in reverse direction, these current limits have some variation as input voltage changes. The input and output current regulators offer more accurate current limits.

The input voltage regulator is typically used in applications with solar panels or high impedance power sources, and will reduce the current if input voltage drops below the set point.

The operating mode of the controller is determined through the MODE pin (jumper JP1) and can be set to discontinuous mode, forced continuous mode and Burst Mode[®] operation.

The LT8705A is capable of bidirectional current flow when operating in forced continuous operation. It is important to know that additional circuitry is required for controlled reverse current operation, and this additional circuitry can be elaborate in high power applications where tight control of current amplitude is required.

The SYNC inputs are used to synchronize the two LT8705A power stages with 180-degree phase shift. The DC2285A demo board contains a multiphase clock.

The LT8705A has internal series regulators that provide $INTV_{CC}$ voltage (6.3V Typ) from V_{IN} or $EXTV_{CC}$. Especially in high power applications the internal dissipation of these series regulators can be high. The DC2285A demo board includes an LT8631 buck regulator that is configured for 7.8V. By connecting this low voltage to V_{IN} and $EXTV_{CC}$ the power dissipation is reduced. The auxiliary 7.8V can also be used to power external circuitry.

The LT8705A data sheet gives a complete description of the part, operation and application information. The data sheet should be read in conjunction with this quick start guide for demo circuit 2285A. The input voltage range of the LT8705A itself is 2.8V (with external auxiliary voltage > 6.4V) to 80V and the output range is 1.3V to 80V. The DC2285A demo board has an optional signal interface that makes it easy to add potentiometers and switches (or a microcontroller) for accurate external control of the power stages.

The LT8705AEUHF is assembled in a 38-lead (5mm × 7mm) plastic QFN package with a thermal pad underneath the chip. Proper board layout is essential for maximum thermal and electrical performance. The DC2285A circuit board has mounting holes for an optional heat sink and NTC resistor for monitoring heat sink temperature.

Design files for this circuit board are available at <http://www.linear.com/demo/DC2285A>

LT, LT, LTC, LTM, Linear Technology, the Linear logo and Burst Mode are registered trademarks of Analog Devices, Inc. All other trademarks are the property of their respective owners.

DEMO MANUAL

DC2285A

PERFORMANCE SUMMARY Specifications are at $T_A = 25^\circ\text{C}$

SYMBOL	PARAMETER	CONDITIONS	MIN	TYP	MAX	UNITS
V_{IN}	Input Supply Range		36		75	V
V_{OUT}	Output Voltage			48		V
I_{OUT}	Maximum Output Current	(Current limited at 20A)		20		A
F_{SW}	Switching Frequency			120		kHz
EFF	Efficiency	$V_{IN} = 36\text{V } I_{OUT} = 18\text{A}$ (Set FB_{IN} to 3.3V) $V_{IN} = 48\text{V } I_{OUT} = 18\text{A}$ $V_{IN} = 60\text{V } I_{OUT} = 18\text{A}$ $V_{IN} = 75\text{V } I_{OUT} = 18\text{A}$ (Disable OVP at 74.6V)		98.6 98.7 99.0 98.7		% % % %

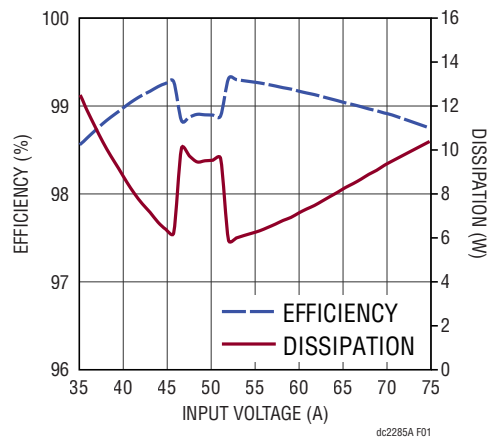

Figure 1. Efficiency and Dissipation at 18A Load

QUICK START PROCEDURE

1. Demonstration circuit 2285A is easy to set up to evaluate the performance of the LT8705A. Refer to Figure 2 for proper measurement equipment setup and follow the procedure below. Make sure the configuration jumpers are set correctly.
2. With power off, connect the input power supply to V_{IN} (J3) and GND (J4).
3. Connect the SHUTDOWN pin (J7:10) to V_{AUX} (J7:12) to disable the board.
4. Apply 48V to the input. The power source must have greater than 38A capability if you want to evaluate the board with full load over the input range.
5. Open the connection from SHUTDOWN to V_{AUX} to enable the board.
6. Note that the demo circuit will operate at V_{IN} down to 32V, as set by the FB_{IN} loop. If operation at this low input voltage is not preferred, increase the value of R67.
7. Once the proper output voltage is established, adjust the load and the input voltage within the operating range and observe the output voltage regulation, efficiency and other parameters as needed. When measuring input/output voltages, measure at the input/output terminals of the board to avoid measurement error caused by voltage drops in cables.
8. To measure input/output voltage ripple, avoid a long ground lead on the oscilloscope probe. A commonly accepted method is to remove the oscilloscope probe end cap and ground lead and set the 20MHz bandwidth limit on the oscilloscope. Measure the input/output voltage ripple by touching the probe tip directly to the positive terminal of the input or output capacitor. Connect the probe ground terminal to the board's GND plane near the capacitor with a very short wire.

QUICK START PROCEDURE

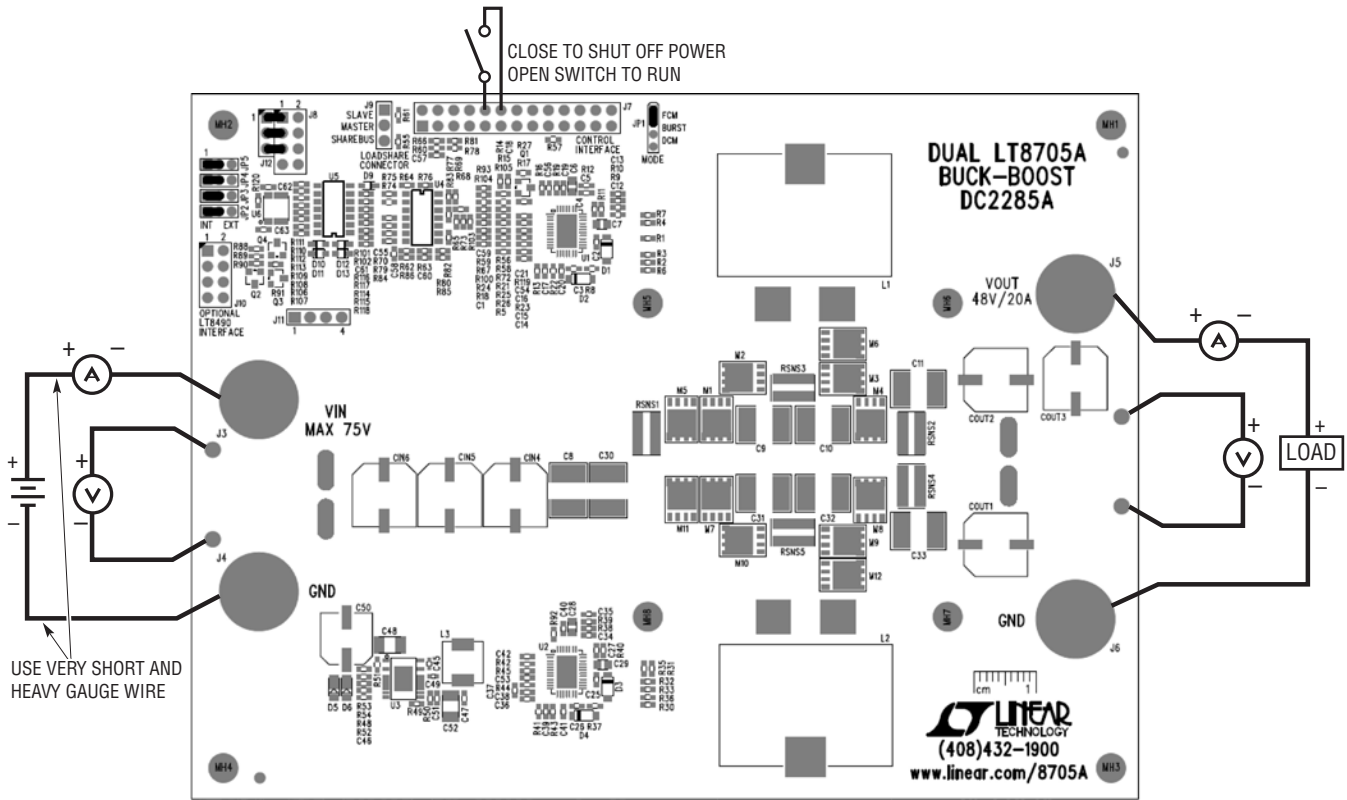

Figure 2. Proper Measurement Equipment Setup

PARTS LIST

ITEM	QTY	REFERENCE	PART DESCRIPTION	MANUFACTURER/PART NUMBER
Required Circuit Components				
1	3	CIN4, CIN5, CIN6	CAP, ALUM., 33 μ F, 80V, 20%	PANASONIC, EEHZA1K330P
2	3	COU1, COU2, COU3	CAP, ALUM., 56 μ F, 63V, 20%	SUN ELEC., 63HVH56M
3	3	C1, C53, C56	CAP, CER., 10000pF, X7R, 25V, 10%, 0603	MURATA, GRM188R71E103KA01D
4	4	C2, C3, C25, C26	CAP, CER., 0.22 μ F, X7R, 16V, 10%, 0603	TDK, C1608X7R1C224K080AC
5	2	C4, C27	CAP, CER., 0.1 μ F, X7R, 16V, 10%, 0603	MURATA, GRM188R71C104KA01D
6	1	C5	CAP, CER., 0.47 μ F, X7R, 16V, 10%, 0603	MURATA, GRM188R71C474KA88D
7	4	C6, C7, C28, C29	CAP, CER., 1 μ F, X7R, 16V, 10%, 0805	MURATA, GRM21BR71C105KA01L
8	8	C8, C9, C10, C11, C30-C33	CAP, CER., 10 μ F, X7S, 100V, 20%, 2220	TDK, CKG57KX7S2A106M335JH
9	4	C12, C13, C34, C35	CAP, CER., 1000pF, X7R, 25V, 10%, 0603	MURATA, GRM188R71E102KA01D
10	2	C14, C36	CAP, CER., 1 μ F, X7R, 16V, 10%, 0603	MURATA, GRM188R71C105KA12D
11	1	C15	CAP, CER., 6800pF, X7R, 25V, 10%, 0603	MURATA, GRM188R71E682KA01D
12	2	C16, C38	CAP, CER., 220pF, NP0, 25V, 10%, 0603	AVX, 06033A221KAT2A
13	6	C19, C20, C21, C40, C41, C42	CAP, CER., 4.7 μ F, X5R, 16V, 10%, 0603	TDK, C1608X5R1C475K080AC
14	1	C37	CAP, CER., 4700pF, NP0, 50V, 5%, 0603	MURATA, GRM1885C1H472JA01D
15	4	D1, D2, D3, D4	DIODE, 200V, 1A, SOD123F	CENTRAL SEMI., CMMR1U-02
16	2	L1, L2	IND., PWR., HIGH CURRENT, 15 μ H, \pm 10%	COILCRAFT, SER2918H-153KL
17	4	M1, M4, M7, M8	XSTR., MOSFET, N-CH, 80V, 100A, PG-TDSON-8	INFINEON, BSC040N08NS5
18	4	M2, M3, M9, M10	XSTR., MOSFET, N-CH, 80V, PG-TDSON-8	INFINEON, BSC117N08NS5
19	1	RSNS1	RES, CHIP, SENSE, 0.003 Ω , 3W, 1%, WIDE 2512	SUSUMU, KRL6432E-M-R003-F-T1
20	2	RSNS2, RSNS4	RES, CHIP, SENSE, 0.004 Ω , 3W, 1%, WIDE 2512	SUSUMU, KRL6432E-M-R004-F-T1
21	2	RSNS3, RSNS5	RES, CHIP, SENSE, 0.006 Ω , 3W, 1%, WIDE 2512	SUSUMU, KRL6432E-M-R006-F-T1
22	8	R1-R4, R30-R33	RES, CHIP, 1 Ω , 1/10W, 1%, 0603	VISHAY, CRCW06031R00FKEA
23	2	R8, R37	RES, CHIP, 3.3 Ω , 1/10W, 1%, 0603	VISHAY, CRCW06033R30FKEA
24	4	R9, R10, R38, R39	RES, CHIP, 10 Ω , 1/10W, 1%, 0603	VISHAY, CRCW060310R0FKEA
25	2	R11, R40	RES, CHIP, 22.1 Ω , 1/10W, 1%, 0603	VISHAY, CRCW060322R1FKEA
26	1	R12	RES, CHIP, 49.9 Ω , 1/10W, 1%, 0603	VISHAY, CRCW060349R9FKEA
27	1	R16	RES, CHIP, 100k, 1/10W, 1%, 0603	VISHAY, CRCW0603100KFKEA
28	1	R65	RES, CHIP, 10k, 1/10W, 1%, 0603	VISHAY, CRCW060310K0FKEA
29	1	R21	RES, CHIP, 23.7k, 1/10W, 1%, 0603	VISHAY, CRCW060323K7FKEA
30	2	R22, R43	RES, CHIP, 365k, 1/10W, 1%, 0603	VISHAY, CRCW0603365KFKEA
31	1	R23	RES, CHIP, 20k, 1/10W, 1%, 0603	VISHAY, CRCW060320K0FKEA
32	1	R26	RES, CHIP, 750k, 1/10W, 1%, 0603	VISHAY, CRCW0603750KFKEA
33	1	R42	RES, CHIP, 12.1k, 1/10W, 1%, 0603	VISHAY, CRCW060312K1FKEA
34	1	R45	RES, CHIP, 590k, 1/10W, 1%, 0603	VISHAY, CRCW0603590KFKEA
35	1	R44	RES, CHIP, 16.9k, 1/10W, 1%, 0603	VISHAY, CRCW060316K9FKEA
36	1	R73	RES, CHIP, 34.8k, 1/10W, 1%, 0603	VISHAY, CRCW060334K8FKEA
37	1	R75	RES, CHIP, 36.5k, 1/10W, 1%, 0603	VISHAY, CRCW060336K5FKEA
38	2	R79, R80	RES, CHIP, 38.3k, 1/10W, 1%, 0603	VISHAY, CRCW060338K3FKEA

DEMO MANUAL

DC2285A

PARTS LIST

ITEM	QTY	REFERENCE	PART DESCRIPTION	MANUFACTURER/PART NUMBER
39	1	R81	RES, CHIP, 48.7k, 1/10W, 1%, 0603	VISHAY, CRCW060348K7FKEA
40	1	R82	RES, CHIP, 60.4k, 1/10W, 1%, 0603	VISHAY, CRCW060360K4FKEA
41	2	U1, U2	I.C., BUCK BOOST DC/DC CONTROLLER, 38-QFN	LINEAR TECH., LT8705AEUHF#PBF
42	1	U4	I.C., OP AMP, SO14	LINEAR TECH., LTC2052CS#PBF
Additional Demo Board Circuit Components				
1	7	C1, C55, C57, C58, C59, C60, C61	CAP, CER., 10000pF, X7R, 25V, 10%, 0603	MURATA, GRM188R71E103KA01D
2	1	C46	CAP, CER., 0.1μF, X7R, 16V, 10%, 0603	MURATA, GRM188R71C104KA01D
3	1	C47	CAP, CER., 1μF, X7R, 16V, 10%, 0603	MURATA, GRM188R71C105KA12D
4	3	C17, C18, C39	CAP, CER., 22pF, NPO, 25V, 5%, 0603	AVX, 06033A220JAT2A
5	1	C45	CAP, CER., 0.1μF, X7R, 10V, 10%, 0402	MURATA, GRM155R71A104KA01D
6	1	C48	CAP, CER., 1μF, X7R, 100V, 10%, 1210	AVX, 12101C105KAT2A
7	1	C49	CAP, CER., 2.2μF, X5R, 10V, 10%, 0402	MURATA, GRM155R61A225KE95D
8	1	C50	CAP, ALUM., 22μF, 100V, 20%	SUNCON, 100CE22BS
9	1	C51	CAP, CER., 4.7pF, NPO, 50V, ±0.25pF, 0603	MURATA, GRM1885C1H4R7CA01D
10	1	C52	CAP, CER., 47μF, X5R, 10V, 10%, 1210	MURATA, GRM32ER61A476KE20K
11	2	D5, D6	DIODE, SCHOTTKY, 100V, POWERDI123	DIODES INC., DFLS1100-7
12	5	D9, D10, D11, D12, D13	DIODE, 75V, 150mA, SOD-323	VISHAY, 1N4148WS-E3-08
13	1	JP1	HEADER 4-PIN 0.079 SINGLE ROW	WURTH ELEKTRONIK, 62000411121
14	4	JP2, JP3, JP4, JP5	HEADER 3-PIN 0.079 SINGLE ROW	WURTH ELEKTRONIK, 62000311121
15	4	XJP1, XJP2, XJP3, XJP4	SHUNT, 2mm	WURTH ELEKTRONIK, 60800213421
16	0	J1, J2 (OPT)	RIGHT ANGLE CONTACT, 45A	ANDERSON POWER, 1336G1
17	0	J1, J2 (OPT)	HOUSING, +PIN, RED	ANDERSON POWER, 1327-BK
18	0	J1, J2 (OPT)	HOUSING, -PIN, BLACK	ANDERSON POWER, 1327G6-BK
19	0	J1, J2 (OPT)	STAPLES FOR PCB ASSY.	ANDERSON POWER, 114555P2
20	1	J7	HEADER 13-PIN 0.100 DOUBLE ROW	WURTH ELEKTRONIK, 61302621121
21	1	J8	HEADER 4-PIN 0.100 SINGLE ROW	WURTH ELEKTRONIK, 61300411121
22	1	J9	HEADER 3-PIN 0.100 SINGLE ROW	WURTH ELEKTRONIK, 61300311121
23	1	J10	HEADER 4-PIN 0.100 DOUBLE ROW	WURTH ELEKTRONIK, 61300821121
24	0	J11 (OPT)	HEADER 4-PIN , OPTION	
25	1	L3	IND., PWR., 22μH	VISHAY, IHLP2525CZER220M11
26	0	M5, M6, M11, M12 (OPT)	XSTR., MOSFET, OPTION, PG-TDSON-8	
27	1	Q1	TRANS, NPN, 40V, 0.6A, SOT-23	FAIRCHILD SEMI., MMBT3904
28	2	Q2, Q3	TRANS, PNP, 40V, 0.2A , SOT-23	FAIRCHILD SEMI., MMBT3906
29	1	Q4	XSTR., MOSFET, N-CH, 60V, 150MA, SOT-23	DIODES INC., BS170FTA
30	1	RT1	THERMISTOR, 10k, NTC, 0603	MURATA, NCU18XH103J6SRB
31	5	R5, R6, R7, R35, R36	RES, CHIP, 1Ω, 1/10W, 1%, 0603	VISHAY, CRCW06031R00FKEA
32	8	R13, R14, R15, R41, R89, R90, R92, R93	RES, CHIP, 100k, 1/10W, 1%, 0603	VISHAY, CRCW0603100KFKEA

PARTS LIST

ITEM	QTY	REFERENCE	PART DESCRIPTION	MANUFACTURER/PART NUMBER
33	0	R17, R27, R48, R53, R69, R100, R103, R104, R106-R113, R118 (OPT)	RES., OPTION, 0603	
34	10	R18, R56, R57, R59, R60, R91, R115, R116, R117	RES, CHIP, 10k, 1/10W, 1%, 0603	VISHAY, CRCW060310K0FKEA
35	5	R19, R55, R64, R66, R67	RES, CHIP, 1k, 1/10W, 1%, 0603	VISHAY, CRCW06031K00FKEA
36	1	R77	RES, CHIP, 365k, 1/10W, 1%, 0603	VISHAY, CRCW0603365KFKEA
37	1	R24	RES, CHIP, 46.4k, 1/10W, 1%, 0603	VISHAY, CRCW060346K4FKEA
38	1	R25	RES, CHIP, 47.5k, 1/10W, 1%, 0603	VISHAY, CRCW060347K5FKEA
39	1	R49	RES, CHIP, 115k, 1/10W, 1%, 0603	VISHAY, CRCW0603115KFKEA
40	5	R50, R51, R68, R70, R101	RES, CHIP, 1M, 1/10W, 1%, 0603	VISHAY, CRCW06031M00FKEA
41	1	R52	RES, CHIP, 25.5k, 1/10W, 1%, 0603	VISHAY, CRCW060325K5FKEA
42	1	R58	RES, CHIP, 34.8k, 1/10W, 1%, 0603	VISHAY, CRCW060334K8FKEA
43	1	R61	RES, CHIP, 150k, 1/10W, 1%, 0603	VISHAY, CRCW0603150KFKEA
44	2	R62, R63	RES, CHIP, 14.7k, 1/10W, 1%, 0603	VISHAY, CRCW060314K7FKEA
45	1	R72	RES, CHIP, 412k, 1/10W, 1%, 0603	VISHAY, CRCW0603412KFKEA
46	2	R74, R76	RES, CHIP, 36.5k, 1/10W, 1%, 0603	VISHAY, CRCW060336K5FKEA
47	1	R78	RES, CHIP, 38.3k, 1/10W, 1%, 0603	VISHAY, CRCW060338K3FKEA
48	1	R83	RES, CHIP, 576k, 1/10W, 1%, 0603	VISHAY, CRCW0603576KFKEA
49	2	R84, R85	RES, CHIP, 51.1k, 1/10W, 1%, 0603	VISHAY, CRCW060351K1FKEA
50	1	R86	RES, CHIP, 75k, 1/10W, 1%, 0603	VISHAY, CRCW060375K0FKEA
51	1	R88	RES, CHIP, 30.1k, 1/10W, 1%, 0603	VISHAY, CRCW060330K1FKEA
52	1	R102	RES, CHIP, 383k, 1/10W, 1%, 0603	VISHAY, CRCW0603383KFKEA
53	2	R54, R105, R119	RES, CHIP, 0Ω, 1/10W, 1%, 0603	VISHAY, CRCW06030000Z0EA
54	1	R114	RES, CHIP, 422k, 1/10W, 1%, 0603	VISHAY, CRCW0603422KFKEA
55	1	U3	I.C. REGULATOR, 20-TSSOP	LINEAR TECH., LT8631EFE#PBF
56	1	U5	I.C., OP AMP, SO14	LINEAR TECH., LTC2052CS#PBF

Hardware: For Demo Board Only

1	4	J3, J4, J5, J6	STUD, TEST PIN	PEM, KFH-032-10ET
2	8	J3, J4, J5, J6	NUT, BRASS NUTS # 10-32	ANY, 10-32M/S BR PL
3	8	J3, J4, J5, J6	RING, LUG RING # 10	KEYSTONE, 8208
4	4	J3, J4, J5, J6	WASHER, TIN PLATED BRASS	ANY, #10EXT- BZ TN
5	4	MH1-MH4	STAND-OFF, NYLON 0.375"	WURTH ELEKTRONIK, 702933000
6	1		PCB, DC2285A	DEMO CIRCUIT 2285A
7	2		STENCIL, DC2285A (TOP & BOTTOM)	STENCIL DC2285A

SCHEMATIC DIAGRAM

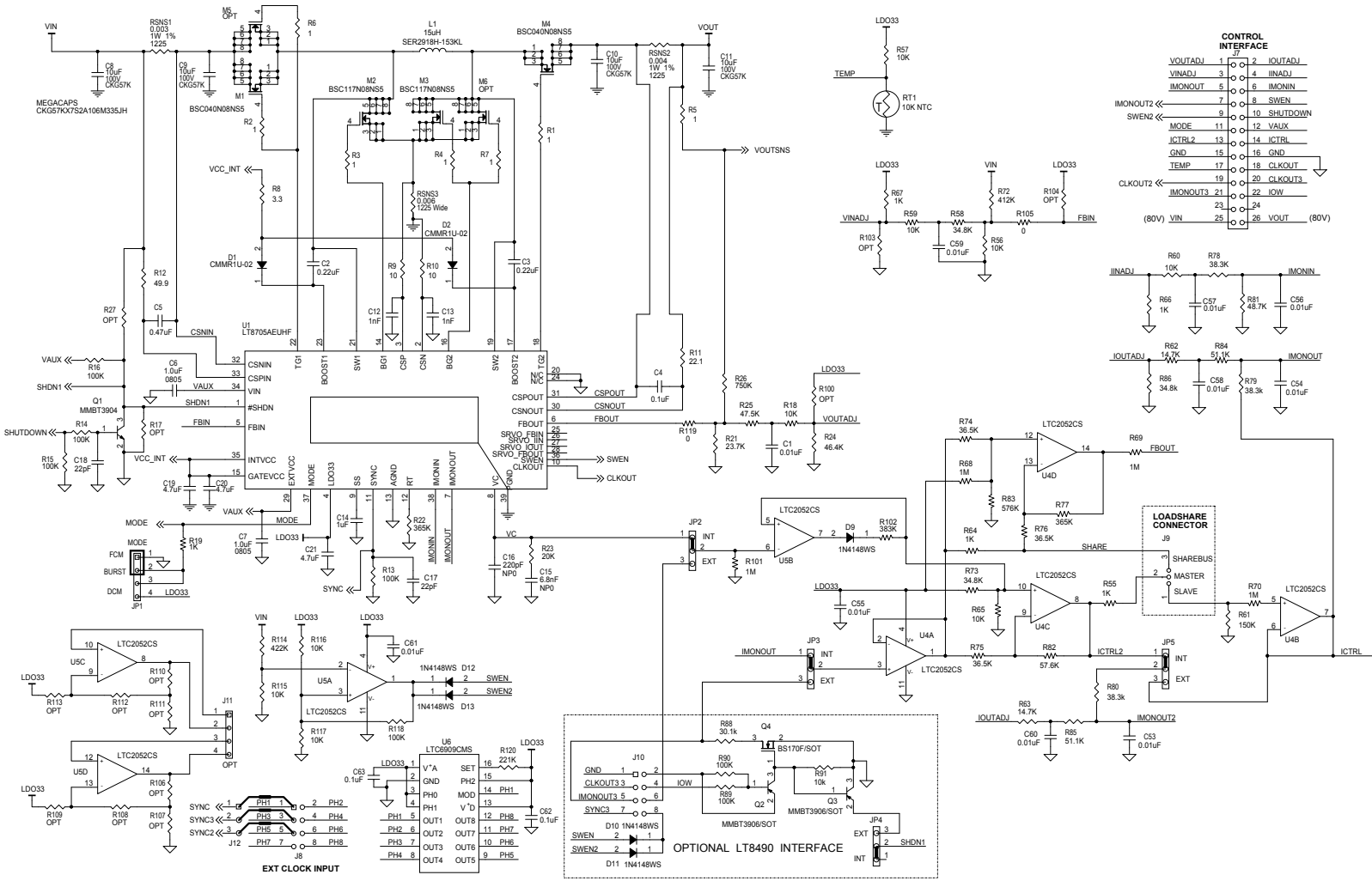

CONTROL INTERFACE

VOUTADJ	1	2	IOUTADJ
VINADJ	3	4	INADJ
IMONOUT	5	6	SWEN
IMONOUT2	7	8	SWEN2
	9	10	SHUTDOWN
MODE	11	12	VAUX
ICTRL2	13	14	ICTRL
GND	15	16	GND
TEMP	17	18	CLKOUT
CLKOUT2	19	20	CLKOUT3
	21	22	IOW
	23	24	
	25	26	VOUT

(80V) VIN (80V)

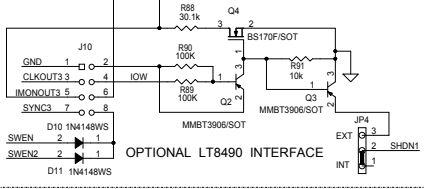
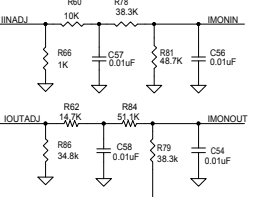

SCHEMATIC DIAGRAM

DEMO MANUAL DC2285A

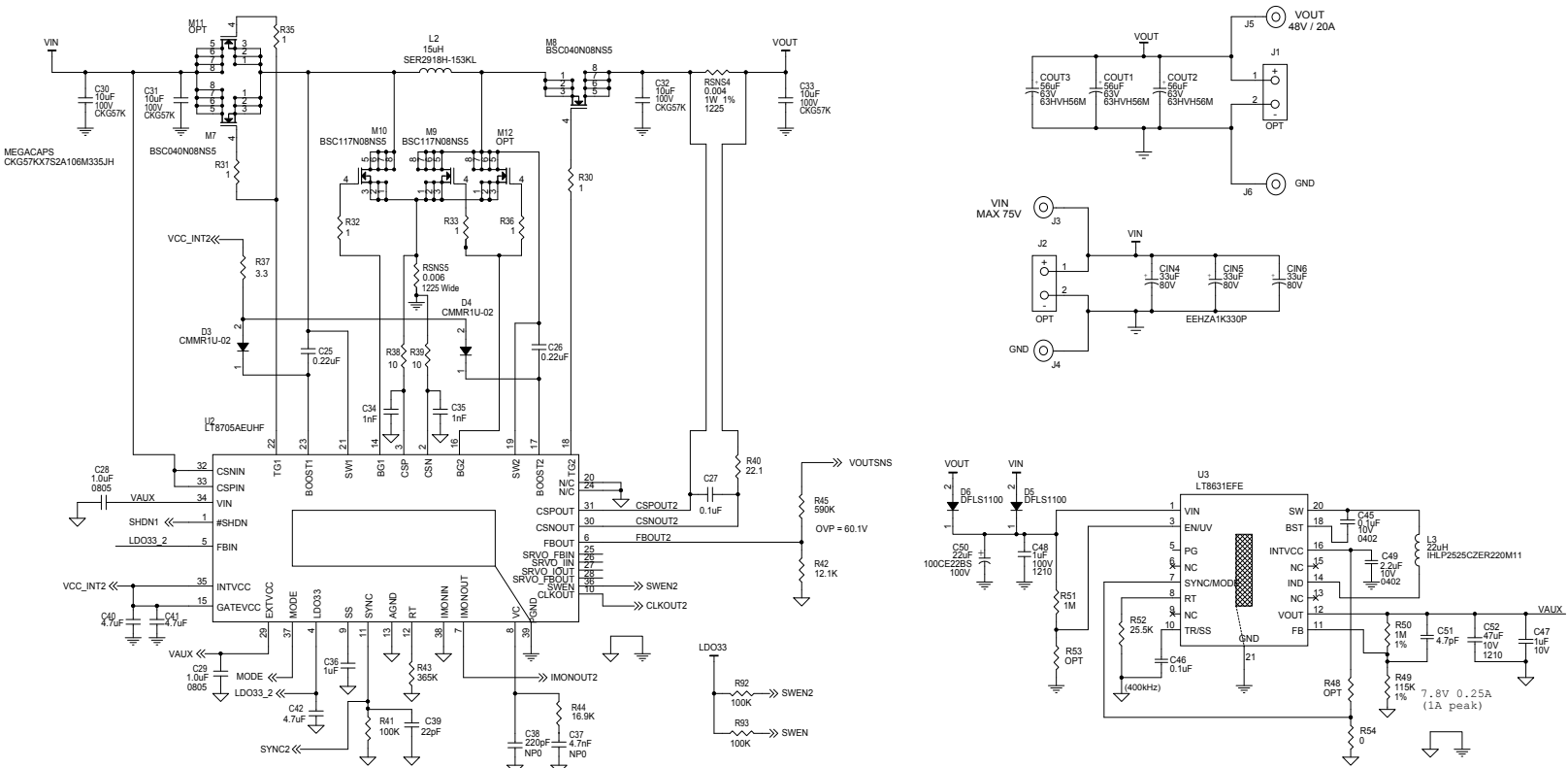

Information furnished by Linear Technology Corporation is believed to be accurate and reliable. However, no responsibility is assumed for its use. Linear Technology Corporation makes no representation that the interconnection of its circuits as described herein will not infringe on existing patent rights.

DEMO MANUAL

DC2285A

DEMONSTRATION BOARD IMPORTANT NOTICE

Linear Technology Corporation (LTC) provides the enclosed product(s) under the following **AS IS** conditions:

This demonstration board (DEMO BOARD) kit being sold or provided by Linear Technology is intended for use for **ENGINEERING DEVELOPMENT OR EVALUATION PURPOSES ONLY** and is not provided by LTC for commercial use. As such, the DEMO BOARD herein may not be complete in terms of required design-, marketing-, and/or manufacturing-related protective considerations, including but not limited to product safety measures typically found in finished commercial goods. As a prototype, this product does not fall within the scope of the European Union directive on electromagnetic compatibility and therefore may or may not meet the technical requirements of the directive, or other regulations.

If this evaluation kit does not meet the specifications recited in the DEMO BOARD manual the kit may be returned within 30 days from the date of delivery for a full refund. **THE FOREGOING WARRANTY IS THE EXCLUSIVE WARRANTY MADE BY THE SELLER TO BUYER AND IS IN LIEU OF ALL OTHER WARRANTIES, EXPRESSED, IMPLIED, OR STATUTORY, INCLUDING ANY WARRANTY OF MERCHANTABILITY OR FITNESS FOR ANY PARTICULAR PURPOSE. EXCEPT TO THE EXTENT OF THIS INDEMNITY, NEITHER PARTY SHALL BE LIABLE TO THE OTHER FOR ANY INDIRECT, SPECIAL, INCIDENTAL, OR CONSEQUENTIAL DAMAGES.**

The user assumes all responsibility and liability for proper and safe handling of the goods. Further, the user releases LTC from all claims arising from the handling or use of the goods. Due to the open construction of the product, it is the user's responsibility to take any and all appropriate precautions with regard to electrostatic discharge. Also be aware that the products herein may not be regulatory compliant or agency certified (FCC, UL, CE, etc.).

No License is granted under any patent right or other intellectual property whatsoever. **LTC assumes no liability for applications assistance, customer product design, software performance, or infringement of patents or any other intellectual property rights of any kind.**

LTC currently services a variety of customers for products around the world, and therefore this transaction **is not exclusive**.

Please read the DEMO BOARD manual prior to handling the product. Persons handling this product must have electronics training and observe good laboratory practice standards. **Common sense is encouraged.**

This notice contains important safety information about temperatures and voltages. For further safety concerns, please contact a LTC application engineer.

Mailing Address:

Linear Technology
1630 McCarthy Blvd.
Milpitas, CA 95035

Copyright © 2004, Linear Technology Corporation