



Chipsmall Limited consists of a professional team with an average of over 10 year of expertise in the distribution of electronic components. Based in Hongkong, we have already established firm and mutual-benefit business relationships with customers from,Europe,America and south Asia,supplying obsolete and hard-to-find components to meet their specific needs.

With the principle of “Quality Parts,Customers Priority,Honest Operation,and Considerate Service”,our business mainly focus on the distribution of electronic components. Line cards we deal with include Microchip,ALPS,ROHM,Xilinx,Pulse,ON,Everlight and Freescale. Main products comprise IC,Modules,Potentiometer,IC Socket,Relay,Connector.Our parts cover such applications as commercial,industrial, and automotives areas.

We are looking forward to setting up business relationship with you and hope to provide you with the best service and solution. Let us make a better world for our industry!



Contact us

Tel: +86-755-8981 8866 Fax: +86-755-8427 6832

Email & Skype: info@chipsmall.com Web: www.chipsmall.com

Address: A1208, Overseas Decoration Building, #122 Zhenhua RD., Futian, Shenzhen, China



LTC1535

Full Duplex, Isolated RS485 Transceiver with Slew Limiting

DESCRIPTION

Demonstration circuit 241B showcases the LTC[®]1535 isolated RS485 transceiver. The LTC1535 features 2,500V isolation; the “left-half” of the chip contains familiar RS485 logic functions and an isolated switching converter, and the “right-half” contains the RS485 transceiver. Both sides include a communications section to send data back and forth across the internal capacitive isolation barrier.

The LTC1535 allows the user to break ground loops that cause problems in large systems, and it can also handle high common mode swings relative to ground without loss of data.

Isolation Considerations

The board, as constructed, is designed for 500V isolation, limited by the CTX02-14659 transformer. A full 3750V UL approvable transformer is also available from Coiltronics as CTX02-14608. Note that the LTC1535 meets only a 2,500V test.

Logic Interface

The left-half of DC241B contains the logic interface sections. Large terminals are provided for +5V and logic ground (V_{CC1} and GND1). The input current is approximately 94mA. The smaller terminals connect to RO (receiver output), \overline{RE} (receiver enable), DE (driver enable), and DI (driver input). The terminals are arranged to match the LTC485 industry-standard pinout.

RS485 Interface

The right-hand side contains the isolated RS485 section. The chip is designed for full duplex operation. So the receiver input A-B and driver output Y-Z are brought out to small terminals. The receiver also has a local output RO2. Larger terminals V_{CC2} and GND2 are powered from the transformer, and require no external power. They are included for the purpose of monitoring the isolated converter output.

Other DC241B Features

Both sides have green LEDs (D1, D3) for monitoring the presence of power. A 3.3k series resistor makes for dim viewing, but conserves current. For accurate power supply current measurement disable the LEDs with JP1 and JP3.

120 Ω , 1/4W terminations are included. They are selected with jumpers JP4 (receiver) and JP5 (driver).

Half-duplex operation is simplified by S1, which simply shorts A to Y and B to Z. Half to the left, full to the right.

The driver slew rate is controlled by JP2; slow left and fast right.

Terminal block J1 is the fastest way to graft DC241B into a system. J1 requires a 2mm screw driver (Xcelite[®] P3321 recommended). Xcelite R181 won't fit no matter how hard you push.

Design files for this circuit board are available at <http://www.linear.com/demo>

Δ , LT, LTC, LTM, Linear Technology and the Linear logo are registered trademarks of Linear Technology Corporation. All other trademarks are the property of their respective owners.

DEMO MANUAL DC241B

PARTS LIST

QTY	REFERENCE	PART DESCRIPTION	MANUFACTURER/PART NUMBER
Required Circuit Components			
2	C1-C2	CAP, TANT 10 μ F 16V 20%	AVX, TAJC106M016R
1	J1	CONN., SCREW TERMINAL BLOCK, 5-PIN 3.5mm	ON-SHORE TECH, ED555/5DS
1	D2	DIODE, SOT23, DUAL SCHOTTKY	ZETEX, BAT54CTA
1	U1	I.C., SOL-28, ISOLATED RS485	LINEAR, LTC1535CSW
5	JP1-5	JUMPER, 3-PIN, 2mm	COMM CON, 2802S-03G2
2	D1, D3	LED, SMT, GREEN, 2. 1V 15mA	PANASONIC, LN1351C- (TR)
2	R3-R4	RES., CHIP 120-OHM 1/4W 5%	TAD, CR18-121JM
2	R1-R2	RES., CHIP 3.3k-OHM 1/16W 5%	TAD, CR16-332JM
1	S1	SWITCH, SLIDE, DPDT	E-SWITCH, EG2271
9	TP1-TP4	TESTPOINT, TURRET, .061	MILL-MAX, 2308-2-00-44
	TP7-TP11		
4	TP5-TP6	TESTPOINT, TURRET, .090	MILL-MAX, 2501-2
	TP12-TP13		
1	T1	TRANSFORMER, SMT	COILTRONICS, CTX02-14659
5	JP1-JP5	SHUNT, 1-PIN, 2mm	COMM CON, CCIJ2mm-138-G

SCHEMATIC DIAGRAM

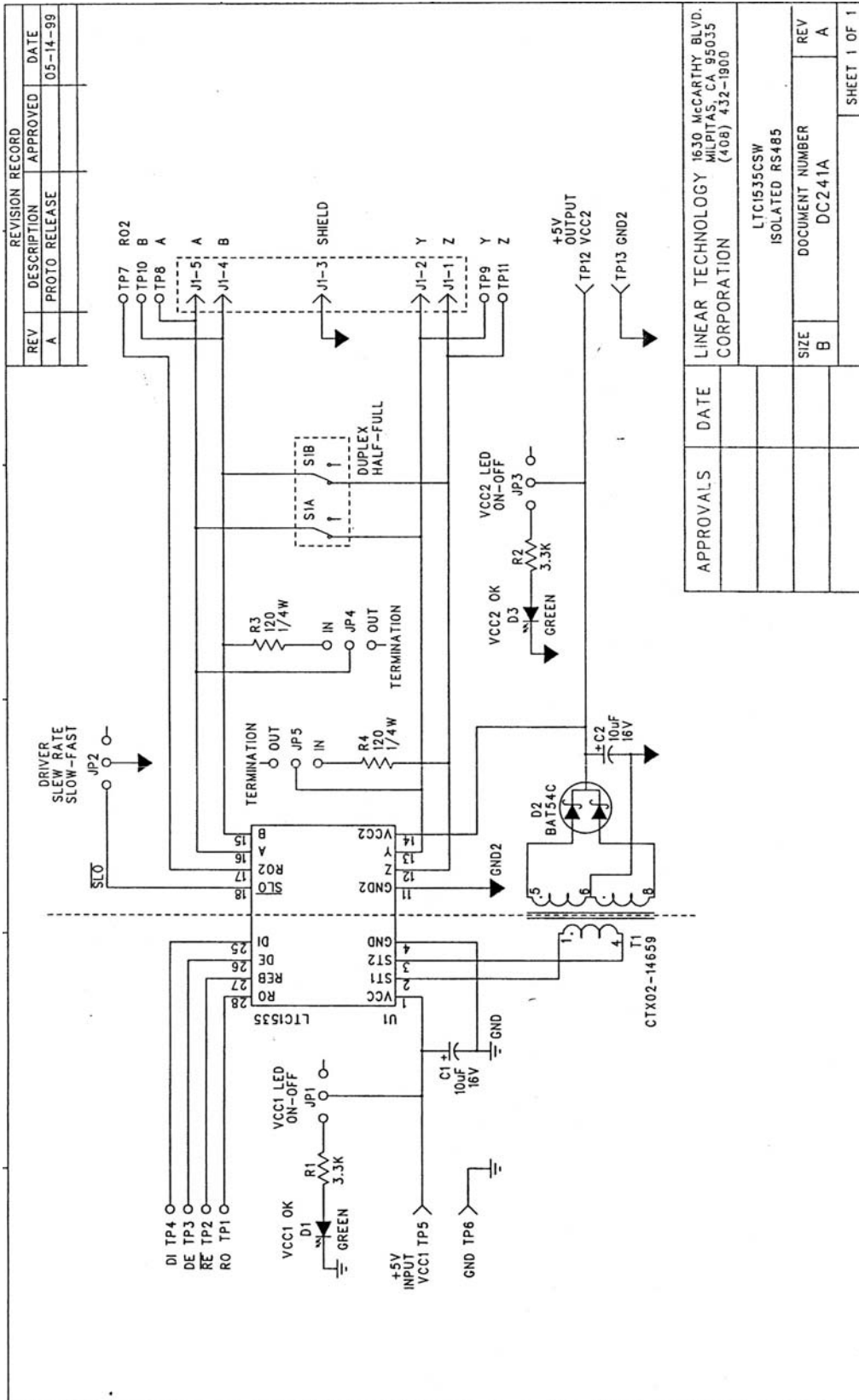

DEMO MANUAL DC241B

DEMONSTRATION BOARD IMPORTANT NOTICE

Linear Technology Corporation (LTC) provides the enclosed product(s) under the following **AS IS** conditions:

This demonstration board (DEMO BOARD) kit being sold or provided by Linear Technology is intended for use for **ENGINEERING DEVELOPMENT OR EVALUATION PURPOSES ONLY** and is not provided by LTC for commercial use. As such, the DEMO BOARD herein may not be complete in terms of required design-, marketing-, and/or manufacturing-related protective considerations, including but not limited to product safety measures typically found in finished commercial goods. As a prototype, this product does not fall within the scope of the European Union directive on electromagnetic compatibility and therefore may or may not meet the technical requirements of the directive, or other regulations.

If this evaluation kit does not meet the specifications recited in the DEMO BOARD manual the kit may be returned within 30 days from the date of delivery for a full refund. **THE FOREGOING WARRANTY IS THE EXCLUSIVE WARRANTY MADE BY THE SELLER TO BUYER AND IS IN LIEU OF ALL OTHER WARRANTIES, EXPRESSED, IMPLIED, OR STATUTORY, INCLUDING ANY WARRANTY OF MERCHANTABILITY OR FITNESS FOR ANY PARTICULAR PURPOSE. EXCEPT TO THE EXTENT OF THIS INDEMNITY, NEITHER PARTY SHALL BE LIABLE TO THE OTHER FOR ANY INDIRECT, SPECIAL, INCIDENTAL, OR CONSEQUENTIAL DAMAGES.**

The user assumes all responsibility and liability for proper and safe handling of the goods. Further, the user releases LTC from all claims arising from the handling or use of the goods. Due to the open construction of the product, it is the user's responsibility to take any and all appropriate precautions with regard to electrostatic discharge. Also be aware that the products herein may not be regulatory compliant or agency certified (FCC, UL, CE, etc.).

No License is granted under any patent right or other intellectual property whatsoever. **LTC assumes no liability for applications assistance, customer product design, software performance, or infringement of patents or any other intellectual property rights of any kind.**

LTC currently services a variety of customers for products around the world, and therefore this transaction **is not exclusive**.

Please read the DEMO BOARD manual prior to handling the product. Persons handling this product must have electronics training and observe good laboratory practice standards. **Common sense is encouraged.**

This notice contains important safety information about temperatures and voltages. For further safety concerns, please contact a LTC application engineer.

Mailing Address:

Linear Technology
1630 McCarthy Blvd.
Milpitas, CA 95035

Copyright © 2004, Linear Technology Corporation