



Chipsmall Limited consists of a professional team with an average of over 10 year of expertise in the distribution of electronic components. Based in Hongkong, we have already established firm and mutual-benefit business relationships with customers from,Europe,America and south Asia,supplying obsolete and hard-to-find components to meet their specific needs.

With the principle of “Quality Parts,Customers Priority,Honest Operation,and Considerate Service”,our business mainly focus on the distribution of electronic components. Line cards we deal with include Microchip,ALPS,ROHM,Xilinx,Pulse,ON,Everlight and Freescale. Main products comprise IC,Modules,Potentiometer,IC Socket,Relay,Connector.Our parts cover such applications as commercial,industrial, and automotives areas.

We are looking forward to setting up business relationship with you and hope to provide you with the best service and solution. Let us make a better world for our industry!



Contact us

Tel: +86-755-8981 8866 Fax: +86-755-8427 6832

Email & Skype: info@chipsmall.com Web: www.chipsmall.com

Address: A1208, Overseas Decoration Building, #122 Zhenhua RD., Futian, Shenzhen, China



LT8391AIFE

60V 2MHz Synchronous Buck-Boost LED Driver

DESCRIPTION

Demonstration circuit DC2575A is a 60V 2MHz synchronous buck-boost LED driver featuring the [LT8391A](#). It accepts an input voltage from 4V to 60V and drives a single string of LEDs up to 16V at 1.5A. DC2575A runs at 2MHz switching frequency without spread spectrum, but spread spectrum frequency modulation (SSFM) can be enabled with a simple jumper. SSFM spreads the switching frequency from f_{SW} to $f_{SW}+25\%$ for reduced EMI.

DC2575A uses AEC-Q automotive-approved components such as power MOSFETs, diodes, input and output capacitors and inductors.

The LT8391A has a wide input voltage range down to 4V and up to 60V. It has adjustable switching frequency between 600kHz and 2MHz. There is a simple jumper option for external frequency synchronization, spread spectrum frequency modulation, or neither.

The LT8391A can be PWM dimmed with an external PWM signal and an internally-generated PWM signal. DC2575A has a jumper that can be set to switch between internally-generated PWM signal, externally-generated PWM signal, and no PWM signal (100% on). It can be analog dimmed with a control voltage on either of its two control pins. LT8391A features both open LED and short LED (LED⁺ to GND) protection as well as a fault output flag.

When run with both PWM dimming and spread spectrum, the spread spectrum aligns itself with the PWM signal for flicker-free operation.

Small ceramic input and output capacitors are used to save space and cost. The board is designed with capacitors on both sides of the synchronous switches for a reduction in radiated EMI. The open LED overvoltage protection uses the IC's constant voltage regulation loop to regulate the output to approximately 18V if the LED string is opened. There is a protection diode from LED⁺ to GND to prevent negative ringing during a short-circuit with long wires.

Undervoltage lockout can be adjusted on the circuit with a few simple resistor choices.

EMI filters and gate resistors on the demo circuit reduce this high power converter's EMI below CISPR 25 Class 5 limits. This is intended for automotive applications where CISPR 25 EMI standards are observed. In non-automotive applications, the EMI may not be as important and the input and output filters, as well as the gate resistors can be removed for higher efficiency. Please note the optional EMI components in the parts list. SSFM is also used to reduce EMI and is not necessary in applications where EMI is not important.

The LT8391A data sheet gives a complete description of the part, operation and applications information. The data sheet must be read in conjunction with this Demo Manual for demonstration circuit DC2575A. The LT8391AIFE is assembled in a 28-lead plastic TSSOP (FE) package with a thermally-enhanced ground pad. Proper board layout is essential for maximum thermal performance. See the data sheet section "Layout Considerations".

Design files for this circuit board are available at <http://www.linear.com/demo/DC2575A>

LT, LT, LTC, LTM, Linear Technology and the Linear logo are registered trademarks of Analog Devices, Inc. All other trademarks are the property of their respective owners.

QUICK START PROCEDURE

Table 1. Typical Performance Summary for DC2575A LT8391A

PARAMETER	CONDITIONS	MIN	TYP	MAX
Input Voltage PV_{IN} Range	Operating $V_{LED} \leq 16V$	4V		60V
Switching Frequency (f_{SW})	$R3 = 59.0k$, $JP1 = NO$ SSFM/SYNC		2.0MHz	
Spread Spectrum (SSFM) Frequency Range	$JP1 = SSFM$ ON	f_{SW}		$f_{SW} \cdot 1.25$
I_{LED}	$R2 = 0.056\Omega$, $7.0V < PV_{IN} < 60V$, $V_{LED} \leq 16V$ $R9 = 90.9k$, $R10 = 113k$		1.5A	
V_{LED} range	$R5 = 1M$, $R6 = 54.9k$	4.8V		16V
Open LED Voltage V_{OUT}	$R5 = 1M$, $R6 = 54.9k$		18.2V	
Typical Efficiency (100% PWM DC)	$PV_{IN} = 13V$, $V_{LED} = 16V$, $I_{LED} = 1.5A$		92%	
Internally-Generated PWM Dimming Range	$JP2 = INT$, $JP3 = INT$	1/128		100%
Internally-Generated PWM Dimming Frequency	$JP2 = INT$, $JP3 = INT$, $R30 = 301k$, $R3 = 59.0k$		488Hz	
Peak Switch Current Limit Boost Region	$R1 = 0.006\Omega$		8.3A	
Peak Switch Current Limit Buck Region	$R1 = 0.006\Omega$		8.3A	
PV_{IN} Undervoltage Lockout (UVLO) falling	$R7 = 383k$, $R8 = 165k$		4.3V	
PV_{IN} Enable Turn-On (EN) Rising	$R7 = 383k$, $R8 = 165k$		5.1V	

Demonstration circuit 2575A is easy to set up to evaluate the performance of the LT8391A follow the procedure:

1. With power off, connect a string of LEDs that will run with forward voltage less than or equal to 16V (at 1.5A) to the LED⁺ and LED⁻ banana jacks on the PCB as shown in Figure 1.
2. Connect the EN/UVLO terminal to GND.
3. Set JP2 to EXT/ON and JP3 to ON for 100% always-on LED operation. Set JP1 to NO SSFM/SYNC to run without SSFM.
4. With power off, connect the input power supply to the PV_{IN} and GND banana jacks. Make sure that the DC input voltage will not exceed 60V.
5. Turn the input power supply on and make sure the voltage is between 4V and 60V for proper operation.
6. Release the EN/UVLO-to-GND connection.
7. Observe the LED string running at the programmed LED current.
8. To change the brightness with analog dimming, simply attach a voltage source to either the CTRL1 or CTRL2 terminal and set the voltage between 0V and 1.5V. See data sheet for details.
9. To change brightness with external PWM dimming, set JP2 to EXT/ON and JP3 to EXT. Attach a 3V rectangular waveform with varying duty cycle to the PWM terminal.
10. To change brightness with internally-generated PWM dimming, set JP2 to INT and JP3 to INT. Adjust the setting of the VR1 variable resistor with a small flat-head screwdriver to toggle between 0% and 100% PWM dimming duty cycle in 1/128 steps.
11. To enable spread spectrum frequency modulation, set JP1 to SSFM ON.

QUICK START PROCEDURE

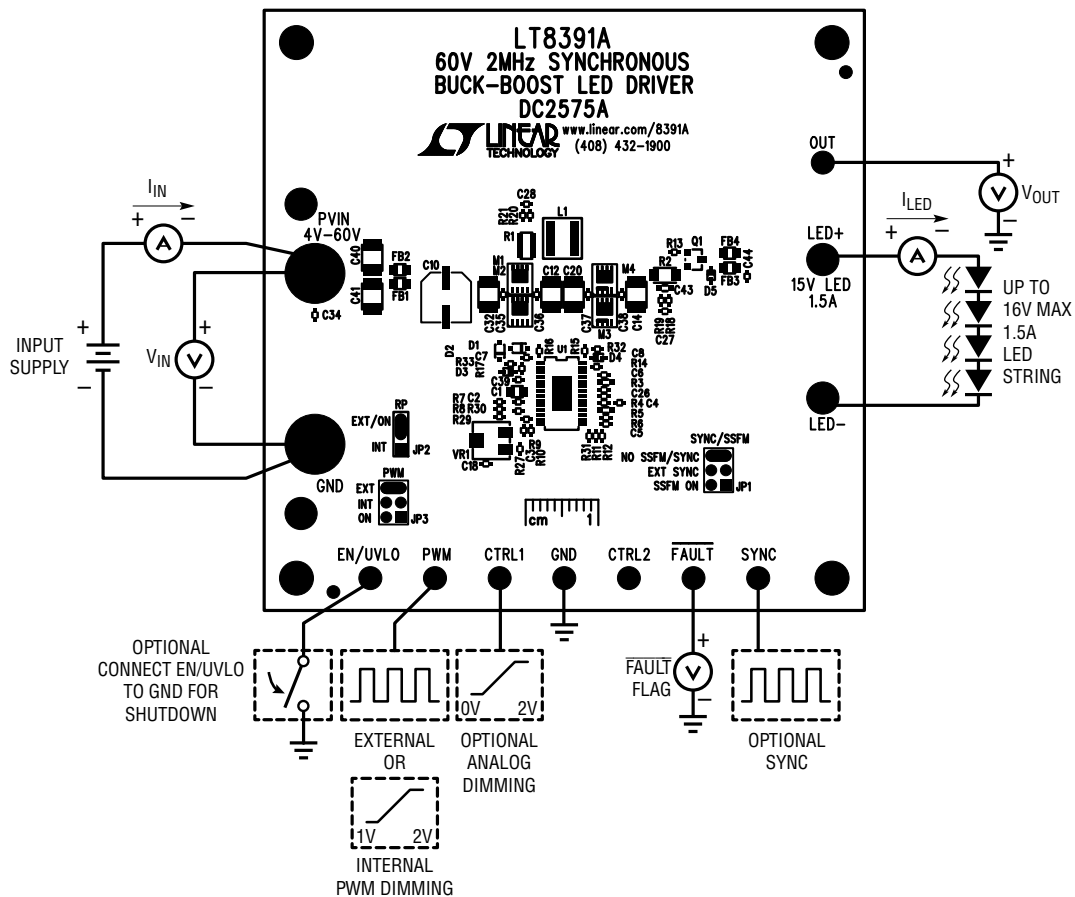

Figure 1. Test Procedure Setup Drawing for DC2575A

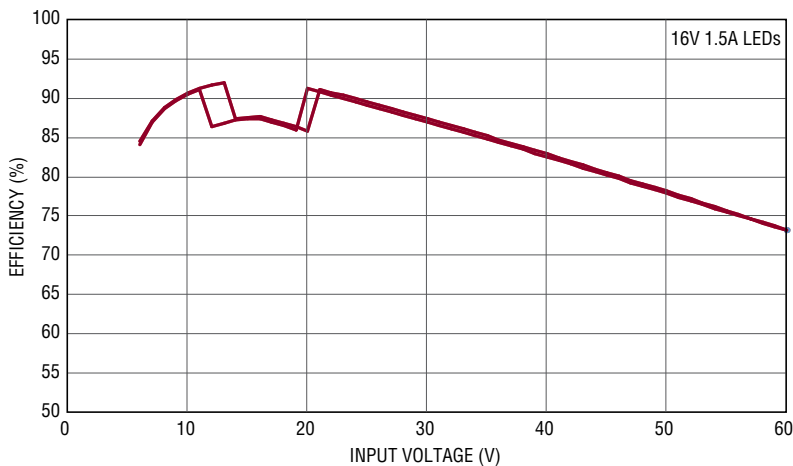

Figure 2. DC2575A Efficiency Versus Input Voltage for 16V 1.5A LED Load

QUICK START PROCEDURE

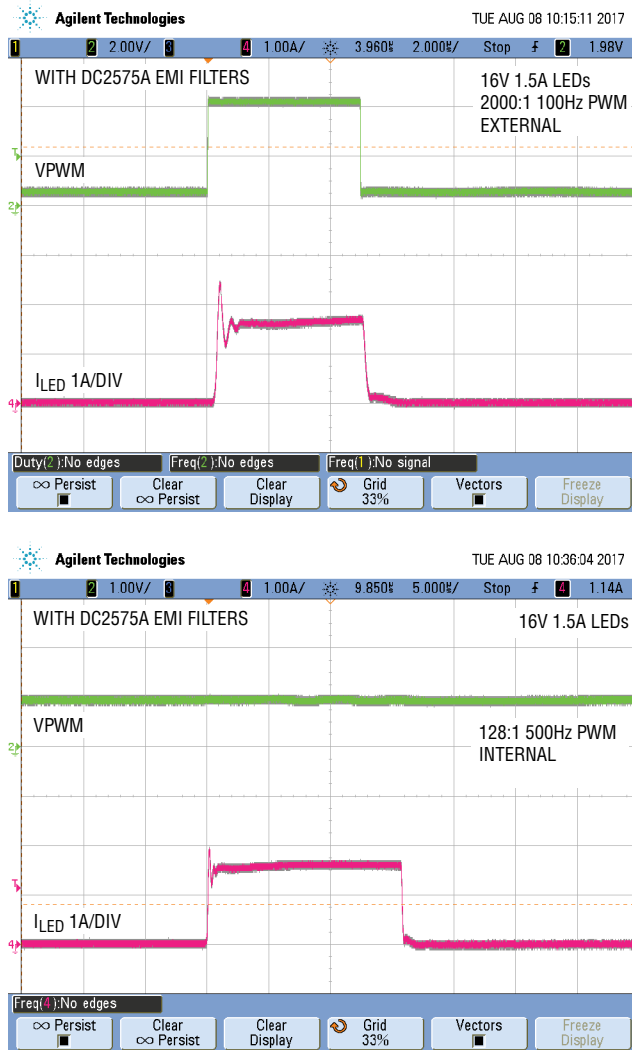

Figure 3. Infinite-Persist Scope Traces Show PWM Dimming and SSFM Working Together for Flicker-Free Brightness Control with Both (a) Externally- and (b) Internally-Generated PWM Dimming (with EMI Filters)

QUICK START PROCEDURE

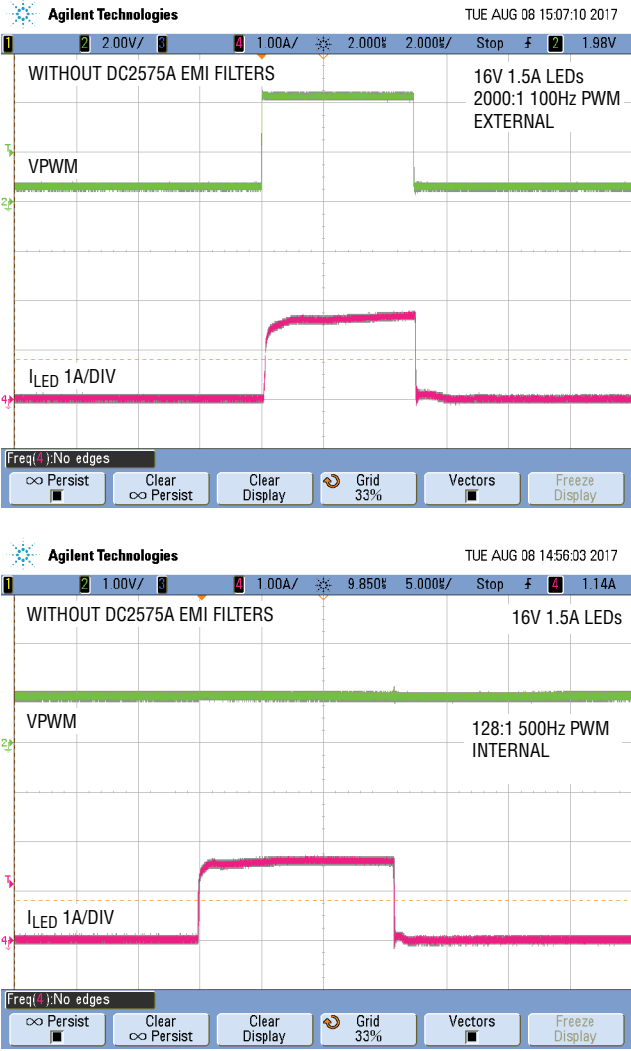

Figure 4. Infinite-Persist Scope Traces Show PWM Dimming and SSFM Working Together for Flicker-Free Brightness Control with Both (a) Externally- and (b) Internally-Generated PWM Dimming (with EMI Filters Removed)

QUICK START PROCEDURE

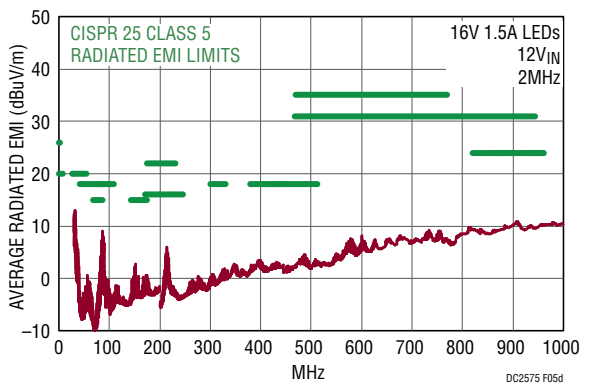
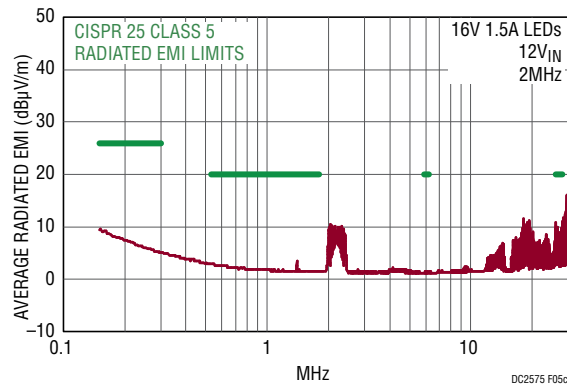
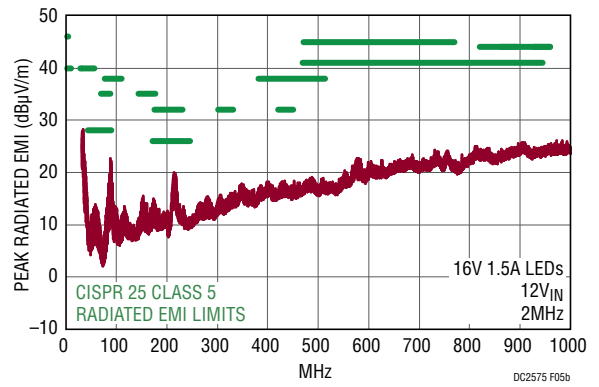
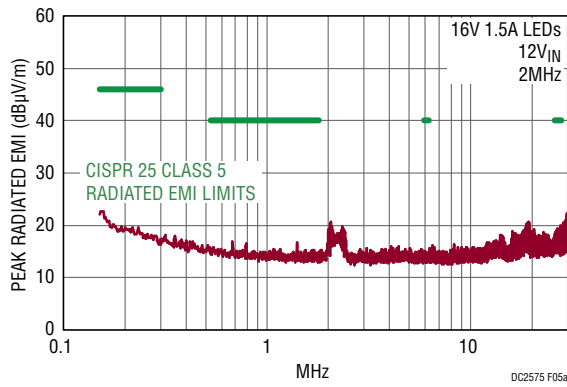

Figure 5. DC2575A LT8391A Passes CISPR 25 Class 5 Radiated EMI

PARTS LIST

ITEM	QTY	REFERENCE	PART DESCRIPTION	MANUFACTURER/PART NUMBER
Required Circuit Components				
1	1	C1	CAP, 1 μ F, X7S, 100V, 10%, 0805	MURATA, GRJ21BC72A105KE11L
1	1	C2	CAP, 4.7 μ F, X5R, 10V, 10%, 0402	TDK, C1005X5R1A475K050BC
1	1	C3	CAP, 0.47 μ F, X5R, 16V, 10%, 0402	TAIYO YUDEN, EMK105ABJ474KV-F
1	1	C4	CAP, 3300pF, X7R, 16V, 10%, 0402	MURATA, GRM15XR71C332KA86D
1	1	C5	CAP, 0.022 μ F, X7R, 25V, 10%, 0402, AEC-Q200, NO SUBS. ALLOWED	MURATA, GCM155R71E223KA55D
1	1	C6	CAP, 1 μ F, X7R, 25V, 10%, 0603	MURATA, GRM188R71E105KA12D
1	2	C7, C8	CAP, 0.1 μ F, X7R, 25V, 10%, 0402, AEC-Q200, NO SUBS. ALLOWED	TDK, CGA2B3X7R1E104K050BB
1	1	C10	CAP, 22 μ F, ALUM., 63V, 20%, SMD 6.3mm \times 7.7mm, D8, AEC-Q200	PANASONIC, EEHZC1J220XP
1	2	C12, C32	CAP, 4.7 μ F, X7S, 100V, 10%, 1210, AEC-Q200, NO SUBS. ALLOWED	MURATA, GCM32DC72A475KE02L
1	2	C14, C20	CAP, 10 μ F, X5R, 25V, 20%, 1210, AEC-Q200, NO SUBS. ALLOWED	MURATA, GRT188R61E106ME13D
1	2	D1, D2	DIODE, SCHOTTKY, 100V, 250mA, SOD323F, AEC-Q101	NEXPERIA, BAT46WJ,115
1	2	M1, M2	XSTR., MOSFET, N-CH, 60V, 22A, LPAK33-8, AEC-Q101	NEXPERIA, BUK9M42-60E
1	2	M3, M4	XSTR., MOSFET, N-CH, 40V, 40A, PG-TSDSON-8, AEC-Q101	INFINEON, IPZ40N04S5L-7R4
1	1	L1	IND., 2.2 μ H, PWR, 20%, 9.2A, 14.5m Ω , 5.48mm \times 5.28mm, XAL5030, AEC-Q200	COILCRAFT, XAL5030-222MEC
1	1	Q1	XSTR., MOSFET, P-CH, 30V, 4.2A, SOT23-3 (TO-236AB), AEC-Q101	NEXPERIA, PMV50EPEA
5	1	R1	RES., 0.006 Ω , 1%, 1.5W, 1206, LONG-SIDE TERM., KRL3216E, SENSE, AEC-Q200	SUSUMU, KRL3216E-C-R006-F-T1
6	1	R2	RES., 0.056 Ω , 1%, 1/2W, 1206, SHORT-SIDE TERM., RL1632, SENSE	SUSUMU, RL1632R-R056-F
7	1	R3	RES., 59.0k Ω , 1%, 1/16W, 0402, AEC-Q200	VISHAY, CRCW040259K0FKED
2	1	R4	RES., 4.7k Ω , 5%, 1/16W, 0402	NIC, NRC04J472TRF
3	1	R5	RES., 1M Ω , 1%, 1/10W, 0603	PANASONIC, ERJ3EKF1004V
16	1	R6	RES., 54.9k Ω , 1%, 1/16W, 0402, AEC-Q200	VISHAY, CRCW040254K9FKED
8	1	R7	RES., 383k Ω , 1%, 1/16W, 0402, AEC-Q200	VISHAY, CRCW0402383KFKED
9	1	R8	RES., 165k Ω , 1%, 1/16W, 0402, AEC-Q200	VISHAY, CRCW0402165KFKED
1	1	U1	IC, 4-Switch Buck-Boost LED CTRLR, TSSOP-28FE	LINEAR TECH., LT8391AIFE#PBF
Optional Low EMI Electrical Components				
1	3	C34, C35, C36	CAP, 0.1 μ F, X5R, 100V, 10%, 0402, NO SUBS. ALLOWED	MURATA, GRM155R62A104KE14D
1	3	C37, C38, C44	CAP, 0.1 μ F, X7R, 25V, 10%, 0402, AEC-Q200, NO SUBS. ALLOWED	TDK, CGA2B3X7R1E104K050BB
1	2	C40, C41	CAP, 4.7 μ F, X7S, 100V, 10%, 1210, AEC-Q200, NO SUBS. ALLOWED	MURATA, GCM32DC72A475KE02L
1	2	D3, D4	DIODE, SCHOTTKY, 20V, 1A, SOD523-2	NEXPERIA, PMEG2010AEB, 115
1	2	FB1, FB2	IND., 220 OHMS, BEAD, FERRITE, 25%, 3A, 40mOHMS, 0805, AEC-Q200	TDK, MPZ2012S221ATD25
1	2	FB3, FB4	IND., 1k OHM, BEAD, FERRITE, 25%, 1.5A, 150mOHMS, 0805, AEC-Q200	TDK, MPZ2012S102ATD25
19	2	R15, R17	RES., 10 OHMS, 5%, 1/16W, 0402	VISHAY, CRCW040210R0JNED
14	2	R32, R33	RES., 5.1 OHMS, 1%, 1/16W, 0402, AEC-Q200	VISHAY, CRCW04025R10FKED

DEMO MANUAL DC2575A

PARTS LIST

ITEM	QTY	REFERENCE	PART DESCRIPTION	MANUFACTURER/PART NUMBER
Other Optional Electrical Components				
1	0	C18, C26, C27, C28, C39 (OPT)	CAP, OPTION, 0402	
1	0	C29, C30 (OPT)	CAP, 0805, OPTION	
1	0	C43 (OPT)	CAP, OPTION, 0603	
1	1	D5	DIODE, SCHOTTKY, 30V, 1A, SOD523-2, AEC-Q101	NEXPERIA, PMEG3010EB,115
1	0	D6, D7 (OPT)	DIODE, OPTION, SOD-123	
18	1	R9	RES., 90.9k Ω , 1%, 1/16W, 0402, AEC-Q200	VISHAY, CRCW040290K9FKED
10	1	R10	RES., 113k Ω , 1%, 1/16W, 0402, AEC-Q200	VISHAY, CRCW0402113KFKED
15	1	R11	RES., 100k Ω , 1%, 1/16W, 0402	NIC, NRC04F1003TRF
4	0	R12, R18, R19, R20, R21, R31 (OPT)	RES., OPTION, 0402	
1	3	R13, R14, R16	RES., 0 Ω , 1/16W, 0402	VISHAY, CRCW04020000Z0ED
17	0	R22, R23 (OPT)	RES., OPTION, 0805	
12	1	R27	RES., 100k Ω , 5%, 1/16W, 0402, AEC-Q200	VISHAY, CRCW0402100KJNED
11	1	R29	RES., 91k Ω , 5%, 1/16W, 0402, AEC-Q200	VISHAY, CRCW040291KOJNED
13	1	R30	RES., 301k Ω , 1%, 1/16W, 0402, AEC-Q200	VISHAY, CRCW0402301KFKED
20	1	VR1	RES., 100k Ω , 20%, 1/4W, SMD 4mm SQUARE, TRIMPOT, J-HOOK, 1-TURN	BOURNS, 3314J-1-104E
Hardware				
1	2	J1, J2	CONN., BANANA JACK, FEMALE, THT, NON-INSULATED, SWAGE	KEYSTONE, 575-4
1	2	JP1, JP3	CONN., HDR, MALE, 2x3, 2mm, THT, STR	WURTH ELEKTRONIK, 62000621121
1	1	JP2	CONN., HDR, MALE, 1x3, 2mm, THT, STR	WURTH ELEKTRONIK, 62000311121
1	3	XJP1, XJP2, XJP3	CONN., SHUNT, FEMALE, 2 POS, 2mm	WURTH ELEKTRONIK, 60800213421
1	4	E1, E2, E9, E10	TEST POINT, TURRET, 0.094", MTG. HOLE	MILL-MAX, 2501-2-00-80-00-00-07-0
1	8	E3, E4, E5, E6, E7, E8, E11, E12	TEST POINT, TURRET, 0.064", MTG. HOLE	MILL-MAX, 2308-2-00-80-00-00-07-0
1	4	MH1, MH2, MH3, MH4	STANDOFF, NYLON, SNAP-ON, 0.375"	WURTH ELEKTRONIK, 702933000

SCHEMATIC DIAGRAM

DEMO MANUAL DC2575A

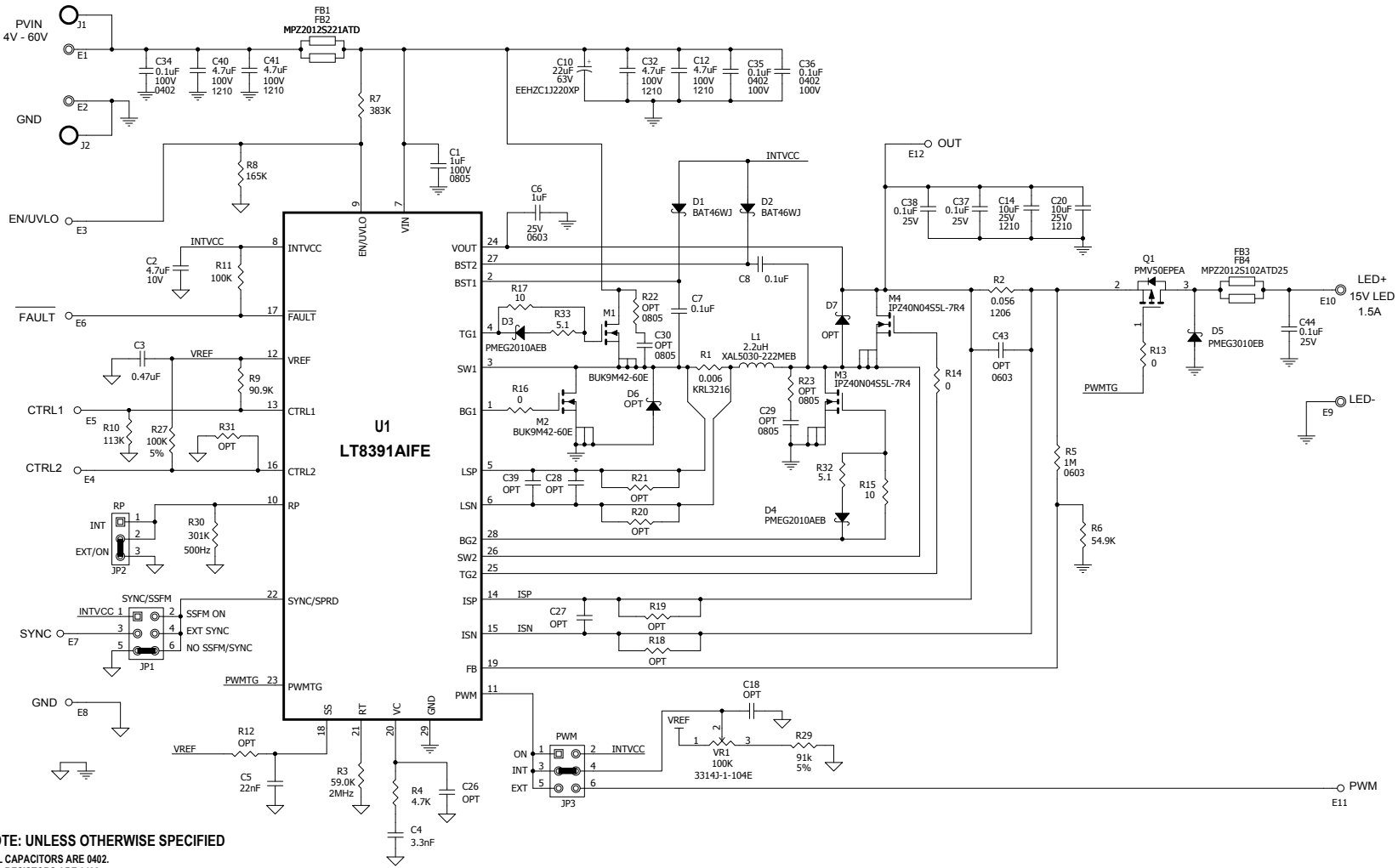

Information furnished by Linear Technology Corporation is believed to be accurate and reliable. However, no responsibility is assumed for its use. Linear Technology Corporation makes no representation that the interconnection of its circuits as described herein will not infringe on existing patent rights.

DEMO MANUAL DC2575A

DEMONSTRATION BOARD IMPORTANT NOTICE

Linear Technology Corporation (LTC) provides the enclosed product(s) under the following **AS IS** conditions:

This demonstration board (DEMO BOARD) kit being sold or provided by Linear Technology is intended for use for **ENGINEERING DEVELOPMENT OR EVALUATION PURPOSES ONLY** and is not provided by LTC for commercial use. As such, the DEMO BOARD herein may not be complete in terms of required design-, marketing-, and/or manufacturing-related protective considerations, including but not limited to product safety measures typically found in finished commercial goods. As a prototype, this product does not fall within the scope of the European Union directive on electromagnetic compatibility and therefore may or may not meet the technical requirements of the directive, or other regulations.

If this evaluation kit does not meet the specifications recited in the DEMO BOARD manual the kit may be returned within 30 days from the date of delivery for a full refund. **THE FOREGOING WARRANTY IS THE EXCLUSIVE WARRANTY MADE BY THE SELLER TO BUYER AND IS IN LIEU OF ALL OTHER WARRANTIES, EXPRESSED, IMPLIED, OR STATUTORY, INCLUDING ANY WARRANTY OF MERCHANTABILITY OR FITNESS FOR ANY PARTICULAR PURPOSE. EXCEPT TO THE EXTENT OF THIS INDEMNITY, NEITHER PARTY SHALL BE LIABLE TO THE OTHER FOR ANY INDIRECT, SPECIAL, INCIDENTAL, OR CONSEQUENTIAL DAMAGES.**

The user assumes all responsibility and liability for proper and safe handling of the goods. Further, the user releases LTC from all claims arising from the handling or use of the goods. Due to the open construction of the product, it is the user's responsibility to take any and all appropriate precautions with regard to electrostatic discharge. Also be aware that the products herein may not be regulatory compliant or agency certified (FCC, UL, CE, etc.).

No License is granted under any patent right or other intellectual property whatsoever. **LTC assumes no liability for applications assistance, customer product design, software performance, or infringement of patents or any other intellectual property rights of any kind.**

LTC currently services a variety of customers for products around the world, and therefore this transaction **is not exclusive**.

Please read the DEMO BOARD manual prior to handling the product. Persons handling this product must have electronics training and observe good laboratory practice standards. **Common sense is encouraged.**

This notice contains important safety information about temperatures and voltages. For further safety concerns, please contact a LTC application engineer.

Mailing Address:

Linear Technology
1630 McCarthy Blvd.
Milpitas, CA 95035

Copyright © 2004, Linear Technology Corporation