



Chipsmall Limited consists of a professional team with an average of over 10 year of expertise in the distribution of electronic components. Based in Hongkong, we have already established firm and mutual-benefit business relationships with customers from,Europe,America and south Asia,supplying obsolete and hard-to-find components to meet their specific needs.

With the principle of “Quality Parts,Customers Priority,Honest Operation,and Considerate Service”,our business mainly focus on the distribution of electronic components. Line cards we deal with include Microchip,ALPS,ROHM,Xilinx,Pulse,ON,Everlight and Freescale. Main products comprise IC,Modules,Potentiometer,IC Socket,Relay,Connector.Our parts cover such applications as commercial,industrial, and automotives areas.

We are looking forward to setting up business relationship with you and hope to provide you with the best service and solution. Let us make a better world for our industry!



## Contact us

Tel: +86-755-8981 8866 Fax: +86-755-8427 6832

Email & Skype: info@chipsmall.com Web: www.chipsmall.com

Address: A1208, Overseas Decoration Building, #122 Zhenhua RD., Futian, Shenzhen, China



## DESCRIPTION

Demonstration circuit 445 is a highly integrated three-output converter designed as a low-cost, small size solution to provide bias voltages in small portable TFT-LCD panels. It is capable of providing 5V/30mA, 15V/2.5mA, and -10V/1mA using the LT1944-1 dual step-up converter from an input as low as 2.7V. 5V and 15V outputs

are adjustable with a change in the feedback resistors. The third output is a negative level shifted voltage off the main regulators.

**Design files for this circuit board are available. Call the LTC factory.**

## QUICK START PROCEDURE

Refer to Figure 1 for proper measurement equipment setup and follow the procedure below:

**NOTE:** When measuring the output ripple, see Figure 2 for proper scope probe technique.

1. Apply a voltage source to the input of the circuit between the Vin and GND terminals. The circuit will start up at an input voltage higher than 1.2V. Do not apply more than 6V to the input.

**NOTE:** The 6V maximum is set by the voltage rating of the input capacitor, the absolute maximum rating for Vin and shutdown pins of LT1944-1 is 15V.

2. Attach voltmeters or oscilloscope probes between each output and its closest GND terminal to monitor the outputs. Switch on the desired channel(s) by setting JP1 and JP2 to the run position.
3. Connect the proper load at each output.

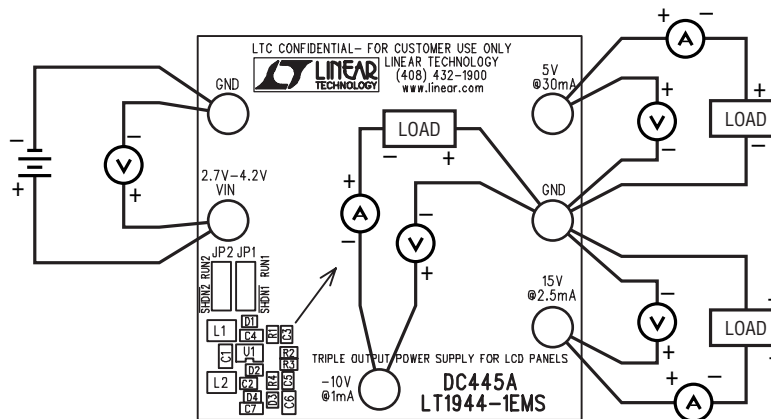

Figure 1. Proper Measurement Equipment Setup

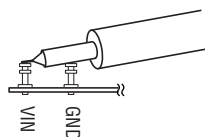

Figure 2. Scope Probe Placement for Measuring Output Ripple

# QUICK START GUIDE FOR DEMONSTRATION CIRCUIT 445

## TRIPLE OUTPUT POWER SUPPLY FOR LCD PANELS

---

**Table 1. Performance Summary**

PARAMETER	CONDITION	VALUE
Minimum Input Voltage		1.2V
Maximum Load Current at 5V Output (minimum)	Vin = 2.7V to 4.2V	30mA
Maximum Load Current at 15V Output (minimum)	Vin = 2.7V to 4.2V	2.5mA
Maximum Load Current at -10V Output (minimum)	Vin = 2.7V to 4.2V	1mA
Typical Output Ripple at 5V	Vin=3.3V, Iout1=30mA, Iout2=2.5mA, Iout3=1mA	120mV
Typical Output Ripple at 15V	Vin=3.3V, Iout1=30mA, Iout2=2.5mA, Iout3=1mA	50mV
Typical Output Ripple at -10V	Vin=3.3V, Iout1=30mA, Iout2=2.5mA, Iout3=1mA	15mV