



Chipsmall Limited consists of a professional team with an average of over 10 year of expertise in the distribution of electronic components. Based in Hongkong, we have already established firm and mutual-benefit business relationships with customers from,Europe,America and south Asia,supplying obsolete and hard-to-find components to meet their specific needs.

With the principle of "Quality Parts,Customers Priority,Honest Operation,and Considerate Service",our business mainly focus on the distribution of electronic components. Line cards we deal with include Microchip,ALPS,ROHM,Xilinx,Pulse,ON,Everlight and Freescale. Main products comprise IC,Modules,Potentiometer,IC Socket,Relay,Connector.Our parts cover such applications as commercial,industrial, and automotives areas.

We are looking forward to setting up business relationship with you and hope to provide you with the best service and solution. Let us make a better world for our industry!



Contact us

Tel: +86-755-8981 8866 Fax: +86-755-8427 6832

Email & Skype: info@chipsmall.com Web: www.chipsmall.com

Address: A1208, Overseas Decoration Building, #122 Zhenhua RD., Futian, Shenzhen, China



QUICK START GUIDE FOR DEMONSTRATION CIRCUIT 471

2A, 200KHZ HIGH VOLTAGE BUCK CONVERTER

LT3430

DESCRIPTION

Demonstration circuit 471 is a 60V, 200kHz, 2A load current, monolithic step-down DC/DC switching converter using the LT3430. With its wide input voltage range, 3A internal power switch, and thermally enhanced package, the LT3430 is a very versatile and powerful IC for DC/DC converters that require compact space and a wide variety of input voltage ranges. The constant 200kHz switching frequency allows all of the components to be small, surface mount devices. The current-mode control topology creates fast transient response and good loop stability with a minimum number of external compensation components and the use of ceramic input and output capacitors if desired. The low resistance internal power switch (0.1Ω) maintains high efficiencies $>80\%$ and up to 90% . The $\overline{\text{SHDN}}$ pin and $30\mu\text{A}$ shutdown current extend battery life. The wide input range allows step-down configurations with input voltages between 5.5V and 60V. Both steady state and transient operation up to 60V is possible. Syn-

chronization of switching frequencies up to 700kHz is possible.

Demonstration Circuit 471 is a step-down converter using the LT3430. The circuit is designed for 7.5V–60V input to 5.0V output at 2A load current for automotive, industrial, portable computers, battery chargers, and distributed power systems. This board was designed for wide input voltage range applications where simplicity, small circuit size, and low component count are important as well as up to 2A of load current. The low-ESR tantalum output capacitor reduces output voltage ripple. Replacing this capacitor with a ceramic capacitor not only demonstrates small size and low cost, but the advantage of current-mode control in step-down applications with a simple compensation network and a feedforward capacitor for more rugged stability and excellent transient response.

Design files for this circuit board are available. Call the LTC factory.

Table 1. Typical Performance Summary

PARAMETER	CONDITION	VALUE
Steady State Input Voltage Range	$V_{\text{OUT}} = 5\text{V}, I_{\text{OUT}} \leq 2\text{A}$	7.5–60V
Maximum Transient Input Voltage	All V_{out} (customized)	60V
V_{OUT}	$I_{\text{OUT}} \leq 2\text{A}$	$5\text{V} \pm 3\%$
Maximum Output Current		2A
Typical Switching Frequency		200kHz
Typical Efficiency	$V_{\text{IN}} = 12\text{V}, V_{\text{OUT}} = 5\text{V}, I_{\text{OUT}} = 2\text{A}$	86%
Output Voltage Ripple	$V_{\text{IN}} = 12\text{V}, V_{\text{OUT}} = 5\text{V}, I_{\text{OUT}} = 2\text{A}$	30mV _{p-p}

QUICK START PROCEDURE

Demonstration circuit 471 is easy to set up to evaluate the performance of the LT3430. Refer to Figure 1 for proper measurement equipment setup and follow the procedure below:

NOTE: Make sure that the input voltage does not exceed 60V.

1. Connect the 7.5V–60V input power supply to the V_{in} and GND terminals on the board.

QUICK START GUIDE FOR DEMONSTRATION CIRCUIT 471

2A, 200KHZ HIGH VOLTAGE BUCK CONVERTER

- Connect an ammeter in series with the input supply to measure input current.
- Connect either power resistors or an electronic load to the Vout and GND terminals on the board.
- Connect an ammeter in series with output load to measure output current.
- Connect a voltmeter across the Vin and GND terminals to measure input voltage.
- Connect a voltmeter across the Vout and GND terminal to measure output voltage.
- After all connections are made, turn on input power and verify that the output voltage is 5.0V.
- The synchronization and shutdown functions are optional and their pins can be left floating (disconnected) if their functions are not being used.

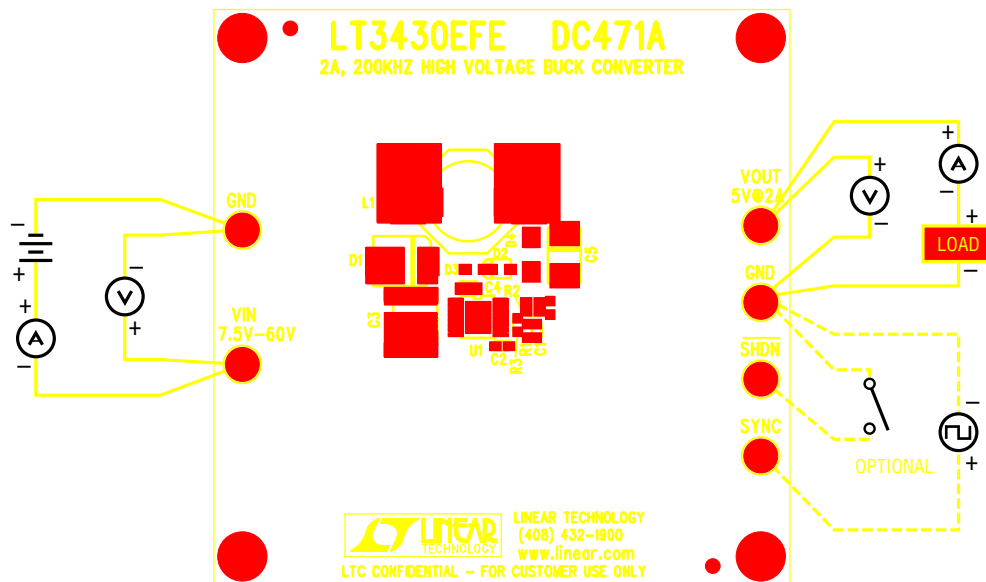

Figure 1. Proper Measurement Equipment Setup

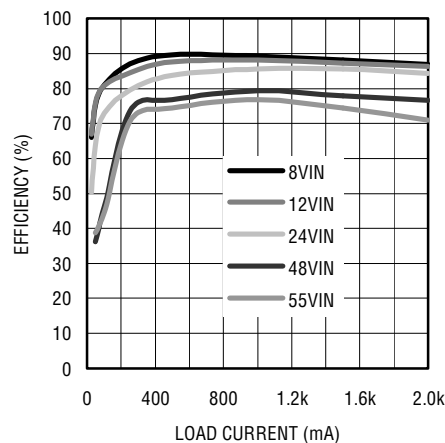

Figure 2. Efficiency vs Load Current

CUSTOMIZING THE BOARD

The components assembled on the board are optimized for a wide input voltage range and a 5V output. The bandwidth can be increased for more specific input voltages such as 12V \pm 10% or 18V–24V with 36V transient if desired (just a few examples). The adjustable feedback resistors allow the output voltage to be customized. For output voltages below 3V, the boost diode should be moved from D2 to D3 to provide the minimum boost voltage required for the internal power switch. Make sure that the boost capacitor (C8) has a voltage rating greater than or equal to the output voltage for applications where the boost diode is placed in D2. However, the boost capacitor must have a voltage rating greater

than the input voltage whenever the boost diode is placed in position D3.

D4 is an optional boost voltage blocking diode. For custom applications in which the output voltage is significantly greater than 5V, this blocking diode reduces the boost driver voltage, reducing the power (and thus heat) dissipation inside the IC. It is recommended that a CMHZ5236B zener diode is used in D4 when $V_{OUT} = 12V$ and the junction temperature is hot without the use of the zener. Note that in order to properly install D4, the small trace connecting the anode and cathode of D4 on the board must be separated (an Exacto knife works well) before D4 is soldered to the board.

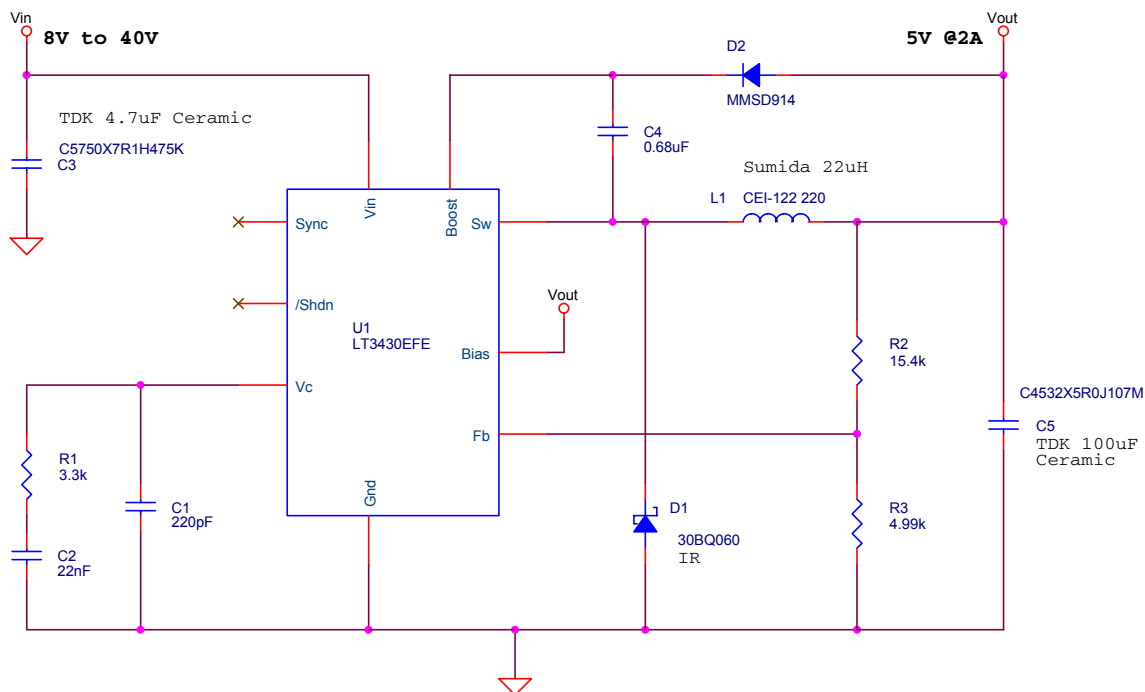

Figure 3. FireWire peripheral application:
8V–40V input, 5V output @2A with all ceramic capacitors and 3.0mm maximum component height.

QUICK START GUIDE FOR DEMONSTRATION CIRCUIT 471

2A, 200KHZ HIGH VOLTAGE BUCK CONVERTER

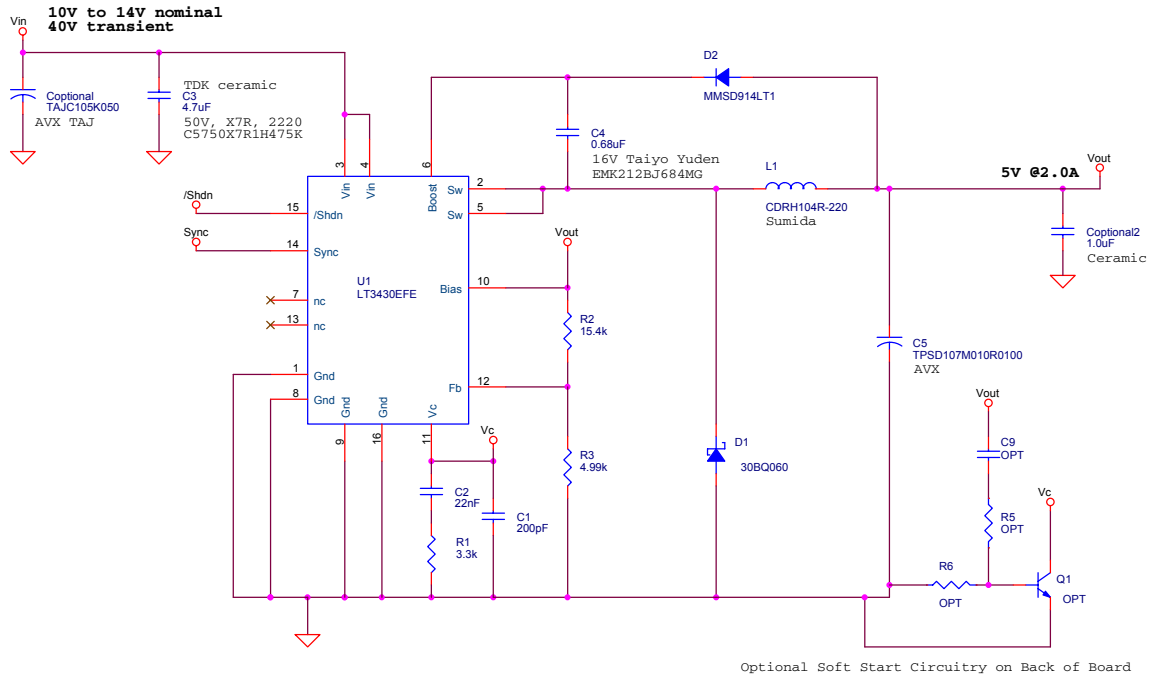

Figure 4. 10V–14V input with 40V input transient, 5V output @2A.

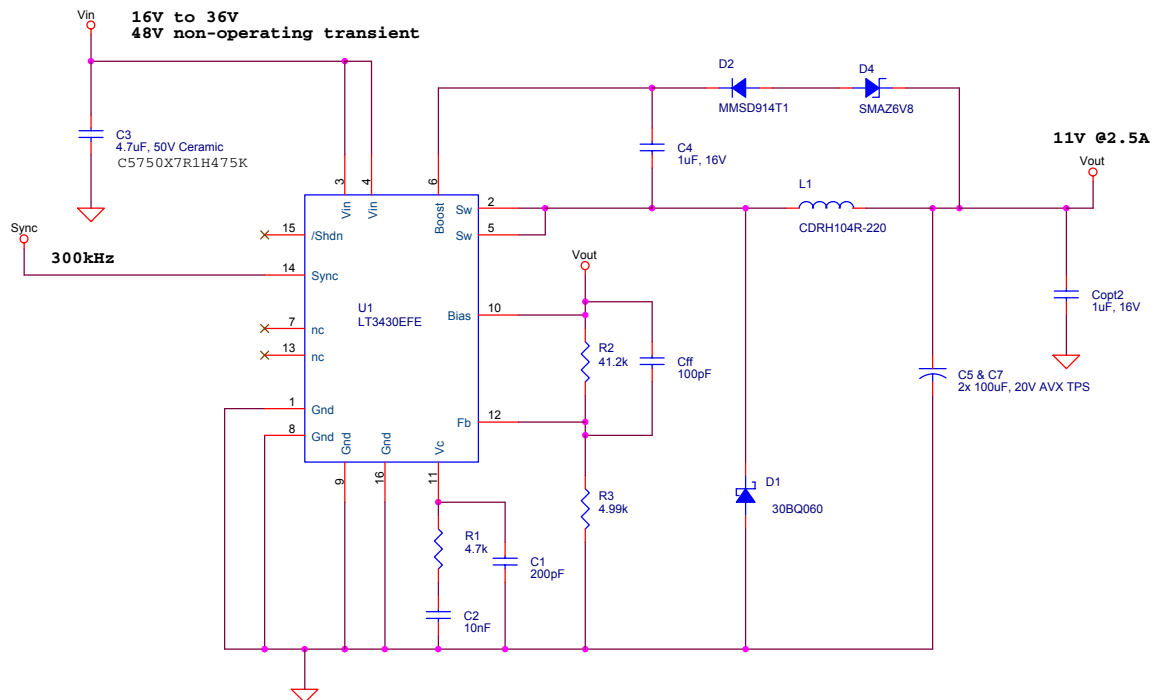
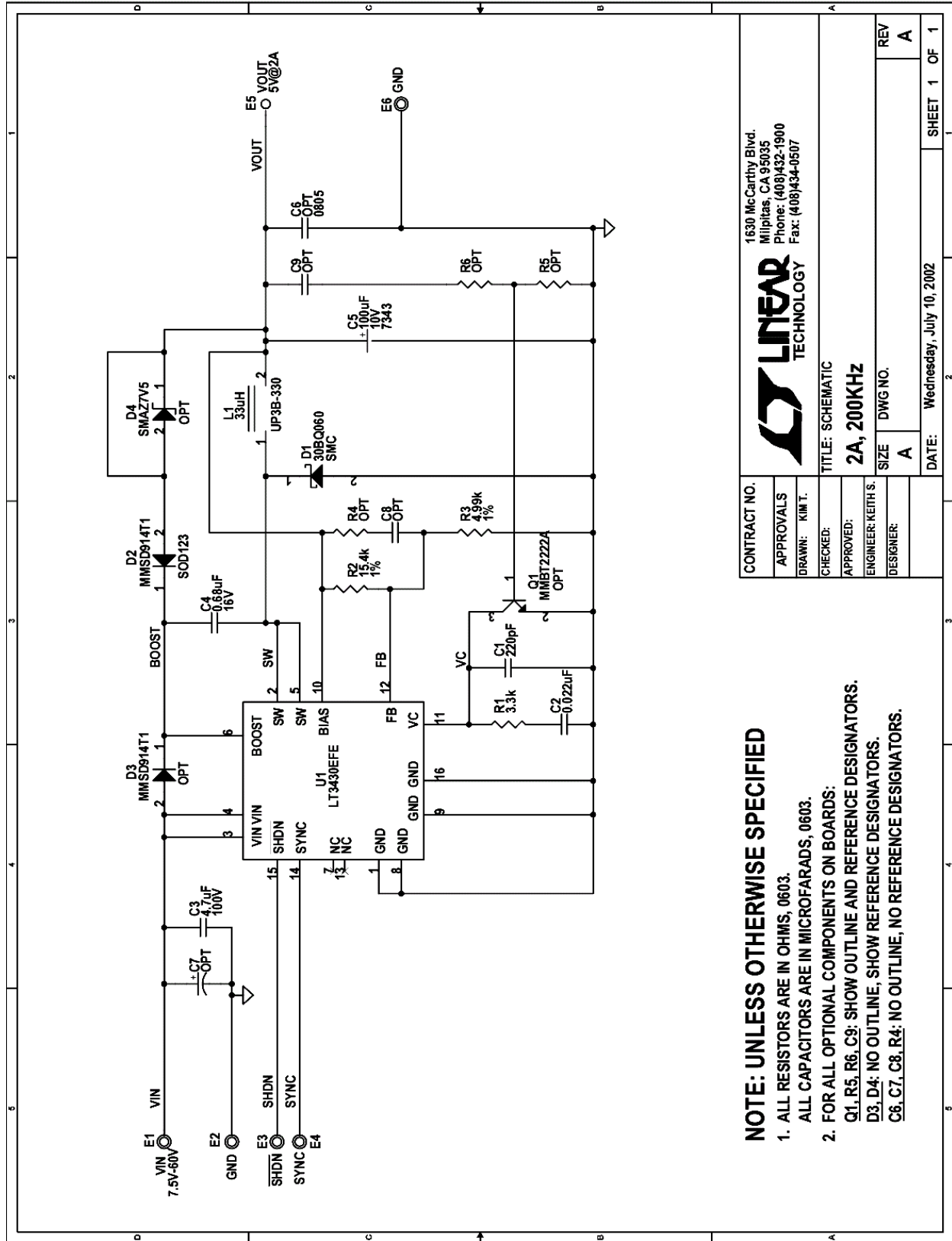

Figure 5. 16V–36V input with 48V input transient, 11V output @2.5A, 300kHz external synchronization. Note that 2.5A may experience thermal derating. See the data sheet.

QUICK START GUIDE FOR DEMONSTRATION CIRCUIT 471

2A, 200KHZ HIGH VOLTAGE BUCK CONVERTER



CONTRACT NO.		1630 McCarthy Blvd. Milpitas, CA 95035 Phone: (408)432-1900 Fax: (408)434-0507	
APPROVALS	DRAWN: KIM T.	CHECKED:	APPROVED:
ENGINEER: KEITH S.	DESIGNER:	TITLE: SCHEMATIC	
SIZE: A	DWG NO.	2A, 200KHZ	
REV: A	DATE: Wednesday, July 10, 2002	SHEET 1 OF 1	

Linear Technology Corporation
LT3430EFE
2A, 200KHz HIGH VOLTAGE BUCK CONVERTER
ENG: KEITH S.

BILL OF MATERIALS
DC471A-1
QTY-525
 10/15/02
 3:16 PM

QUICK START GUIDE FOR DEMONSTRATION CIRCUIT 471
2A, 200KHZ HIGH VOLTAGE BUCK CONVERTER

Item	Qty	Reference	Part Description	Manufacture / Part #	Kit Qty
				NUMBER OF BOARDS =	525
1	1	C1	CAP, NPO 220pF 25V 10%	AVX, 06033A221KAT1A	525
2	1	C2	CAP, X7R 0.022uF 16V 10%	AVX, 0603YC223KAT1A	525
3	1	C3	CAP, Y5V 4.7uF 100V, 80%, C-THCR60	UNITED CHEMI-CON, THCR60E2A475ZT	525
4	1	C4	CAP, X7R 0.68uF 16V 20%	TAIYO YUDEN, EMK212BJ684MG	525
	0	OR	CAP, X5R 1.0uF 16V 10%, 0805	TAIYO YUDEN, EMK212BJ105ZG	0
5	1	C5	CAP, TANT. 100uF 10V 20%, 7343	AVX, TPSD107M010R0100	525
6	0	C6	CAP, 0805	OPT	0
7	0	C7	CAP, C SIZE, 6032	OPT	0
8	0	C8,C9	CAP, 0603	OPT	0
9	1	D1	DIODE SCHOTTKY,3A, 60V,SMA-DIODE	IR, 30BQ060	525
10	1	D2	DIODE, 200mA, 100V, SOD123	ON SEMI., MMSD914T1	525
11	0	D3	DIODE, 200mA, 100V, SOD123	ON SEMI., MMSD914T1	0 (OPT)
12	0	D4	DIODE ZENER, SMA-DIODE	DIODES INC., SMAZ7V5	0 (OPT)
13	6	E1-E6	TP, TURRET, .094"	MILL-MAX, 2501-2	3150
14	1	L1	IND, SMT, 33uH, L-COIL-UP3B	COILTRONICS, UP3B-330	525
	0	OR	IND, SMT, 47uH, L-COIL-UP4B	COILTRONICS, UP4B-470	0
15	0	Q1	TRANS, MMBT2222A, SOT23	DIODES INC., MMBT2222A-7	0 (OPT)
16	1	R1	RES, 3.3k 5%, 0603	AAC, CR16-332JM	525
17	1	R2	RES, 15.4k 1%, 0603	AAC, CR16-1542FM	525
18	1	R3	RES, 4.99k 1%, 0603	AAC, CR16-4991FM	525
19	0	R4,R5,R6	RES, 0603	OPT	0
20	1	U1	IC, LT3430EFE, TSSOPFE16	LINEAR TECH., LT3430EFE	210
21	4	MTG HOLES AT 4 CORNERS	STANDOFF, NYLON HEX #4-40 x 1/4"	MICRO PLASTICS, #14HTSP101	2100
22	4		SCREW, #4-40 x 1/4	ANY	2100
NOTES: UNLESS OTHERWISE SPECIFIED					
1. ALL RESISTORS ARE IN OHMS.					



QUICK START GUIDE FOR DEMONSTRATION CIRCUIT 471

2A, 200KHZ HIGH VOLTAGE BUCK CONVERTER

APPROVED VENDOR LIST

VENDOR	PHONE NUMBER	PART TYPE	WEBSITE ADDRESS
AAC (was TAD)	(800) 508-1521	CHIP RESISTORS	
AAC (was TAD)	(714) 255-9186		
AAVID	(714) 556-2665	HEAT SINKS	
ALLEN BRADLEY	(800) 592-4888	CARBON RESISTORS	
AMP	(717) 564-0100	PC MOUNT BNC	
APEM	(718) 246-1007	SMD TOGGLE/PB SWITCH	
API DELEVAN	(716) 652-3600	INDUCTORS	
AVX	(843) 946-0362	CHIP CAPS	
AVX	(843) 946-0524	CHIP RESISTORS	
AVX	(207) 282-5111	TANTALUM CAPS	
AVX	(843) 946-0323	HIGH VOLTAGE CAPS	
BERG	(800) 237-2374	CONNECTORS	
BH ELECTRONICS	(952) 894-9590	INDUCTORS	
BI TECHNOLOGIES	(714) 447-2656	TRANSFORMERS	
BI TECHNOLOGIES	(714) 447-2345	RES./RES. NETWORKS	
BOURNS	(801) 750-7253	POTENTIOMETERS, SIPS	
CADDOCK ELECTRONICS	(541) 496-0700	HIPO. RES., SIPS, DIPS	
CENTRAL SEMI	(631) 435-1110	SMALL SIGNAL DISCRETES	
CHICAGO MINIAT. LAMP	(201) 489-8989	LEDS	
COILCRAFT	(847) 639-6400	INDUCTORS	
COMM CON	(626) 301-4200	HEADERS, SHUNTS	
CONNEX	(805) 378-6464	BNC CONNECTORS	
COOPER ELECT. TECH.	(561) 752-5000	INDUCTORS	
CORNELL DUBILIER	(508) 996-8561	CAPACITORS	
CTS	(219) 293-7511	RESISTOR ARRAYS	
CUI-STACK	(503) 643-4899	POWER CONNECTORS	
DALE (see Vishay)	(605) 665-1627	INDUCTORS	
DALE (see Vishay)	(605) 665-9301	SENSE RESISTORS	
DATA DISPLAY PRODUCT	(800) 421-6815	LEDS	
DIODES INC.	(805) 446-4800	DIODES	
ELECTRONIC CONCEPTS	(908) 542-7880	400V FILM CAPACITORS	
EPSON	(310) 787-6300	CRYSTALS	
FAIRCHILD	(207) 775-4502	LOGIC	
FAIRCHILD	(408) 822-2126	MOSFETS	
FAIRCHILD	(888) 522-5372	CRG (CUST. RESPONSE)	
FCI	(717) 767-8005	HOT PLUG CONNECTORS	
FUKUSHIMA	(818) 765-8300	MPC RESISTORS	
FUJI	(201) 712-0555	SCHOTTKY DIODES	
GENERAL SEMICONDUCTOR	(516) 847-3000	DIODES	
GOWANDA	(716) 532-2234	INDUCTORS	
GRAYHILL	(708) 354-1040	DIP SWITCHES	
HARRIS	(800) 442-7747	LOGIC	
HEWLETT PACKARD	(800) 235-0312	IR LED	
HITACHI	(408) 433-1990	RF POWER AMPS	

QUICK START GUIDE FOR DEMONSTRATION CIRCUIT 471

2A, 200KHZ HIGH VOLTAGE BUCK CONVERTER

IDT	(408) 727-6116	LOGIC IC
IR	(310) 322-3331	MOSFETS
IRC	(361) 992-7900	SENSE RESISTORS
ITW PAKTRON	(708) 667-3444	CAPACITORS
JOHNSON COMPONENTS	(650) 948-6533	RF CONNECTORS
JOHNSON COMPONENTS	(760) 434-5961	RF CONNECTORS
KEMET	(408) 986-0424	TANTALUM CAPS
KEMET	(864) 963-6300	CRG (CUST. RESPONSE)
KETEMA	(714) 630-0081	SURGE SUPPRESSORS
KEYSTONE	(718) 956-8900	JACKS, TURRETS
LITEON	(408) 241-4588	LEDS, DIODES
LTC	(408) 432-1900	HIGH PERF. I.C.S
MAGNETICS	(800) 245-3984	TOROID CORES ETC.
MARCON	(847) 696-2000	HIGH C/V CAPACITORS
METHODE	(800) 323-6864	ZIF SOCKETS
MF ELECTRONICS	(914) 576-6570	CRYSTAL OSCILLATORS
MICROCHIP	(602) 786-7200	MICROCONTROLLER IC
MICRO PLASTICS	(870) 453-8861	NYLON STANDOFFS
MICRO-SEMI	(617) 926-0404	DIODES
MIDCOM	(605) 886-4385	INDUCTORS
MIDCOM	(800) 643-2661	INDUCTORS
MILL-MAX	(516) 922-6000	TURRETS
MINICIRCUITS	(718) 934-4500	RF TRANSFORMERS
MOTOROLA	(800) 441-2447	LOGIC, REGS
MURATA ELECTRONICS	(770) 436-1300	CAPS., INDUCTORS,
MURATA ELECTRONICS	(800) 831-9172	CRG (CUST. RESPONSE)
MURATA ELECTRONICS	(770) 433-5789	RF DEVICES
NEC/TOKIN	(510) 324-4110	INDUCTORS/HI C/V CAPS
NICHIA	(408) 573-0933	WHITE LEDS
NICHICON	(847) 843-7500	ELECTROLYTIC CAPACITOR
ON SEMICONDUCTOR	(602) 244-6600	DISCRETE DIODES ETC.
ON SHORE	(602) 921-3000	TERMINATORS
PANASONIC	(714) 373-7334	INDUCTORS, POLY CAPS
PANASONIC	(201) 348-5217	LEDS
PANASONIC	(201) 373-7334	SWITCHES
PERICOM	(408) 435-0800	LOGIC IC
PHILIPS	(914) 246-2811	INDUCTORS
PHILIPS	(914) 247-2036	PLANAR INDUCTORS
PHILIPS	(508) 851-2200	DISCRETES, I.C.s
PULSE	(619) 674-8100	INDUCTORS
QT OPTOELECTRONICS	(408) 720-1440	RF SWITCH
RAYCHEM	(800) 227-4856	FUSES
RG ALLEN	(818) 765-8300	METAL OXIDE RESISTORS
RF MICRO DEVICES	(336) 664-1233	RF2138 / RF2140
SAMTEC	(800) 726-8329	WIRE JUMPERS
SANYO	(619) 661-6835	OSCON CAPS
SCHOTT	(507) 532-3201	INDUCTORS, XFORMERS

QUICK START GUIDE FOR DEMONSTRATION CIRCUIT 471

2A, 200KHZ HIGH VOLTAGE BUCK CONVERTER

SCHURTER	(707) 778-6311	FUSES AND HOLDERS
SIGNATRON	(909) 464-1883	DB9 CONNECTORS
SIEMENS	(108) 257-7910	OPTO
SILICONIX	(800) 554-5565	MOSFETS
SILICONIX	(408) 988-8000	MOSFETS
SPRAGUE	(207) 324-4140	CAPACITORS
SULLINS	(760) 744-0125	HEADERS, SHUNTS
SUMIDA	(847) 956-0667	INDUCTORS
SUMIDA	(408) 982-9660	INDUCTORS
TAIYO YUDEN	(408) 573-4150	CHIP CAPS / RES.
TAIYO YUDEN	(800) 348-2496	CRG (CUST. RESPONSE)
TEKTRONIX	(800) 835-9433	SCOPE PROBE SOCKETS
TEMIC	(408) 970-5700	IR PHOTO DIODE
THERMALLOY	(972) 243-4321	HEAT SINKS
THIN FILM TECHNOLOGY	(507) 625-8445	THIN FILM CHIP RESISTORS
TOCOS	(847) 884-6664	SMD POTENTIOMETERS
TOKIN (NEC)	(510) 324-4110	CAPS., INDUCTORS,
TOKO	(847) 699-3430	RF PRODUCTS
TOSHIBA	(714) 455-2000	SINGLE GATE LOGIC
TOSHIBA	(949) 455-2000	LOGIC
UNITED CHEMICON	(847) 696-2000	ELECTROLYTIC CAPACITOR
VISHAY	(605) 665-9301	ZENER/SM. SIGNAL DIODES
VISHAY	(605) 665-9301	INDUCTORS, SENSE Rs
VITRAMON	(203) 268-6261	CERAMIC CHIP CAPACITOR
WIMA	(914) 347-2474	PAPER/FILM CAPACITORS
ZETEX	(631) 366-5068	SMALL SIGNAL DISCRETES
ZIERICK	(800) 882-8020	STAKED PINS

QUICK START GUIDE FOR DEMONSTRATION CIRCUIT 471

2A, 200KHZ HIGH VOLTAGE BUCK CONVERTER

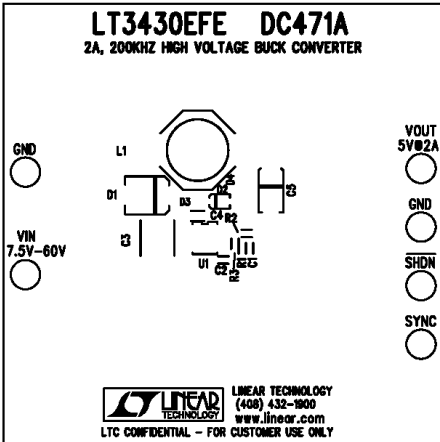

TOP SILKSCREEN
LINEAR TECHNOLOGY
DC471A-1 * LT3430EFE
2A, 200KHZ HIGH VOLTAGE BUCK CONVERTER

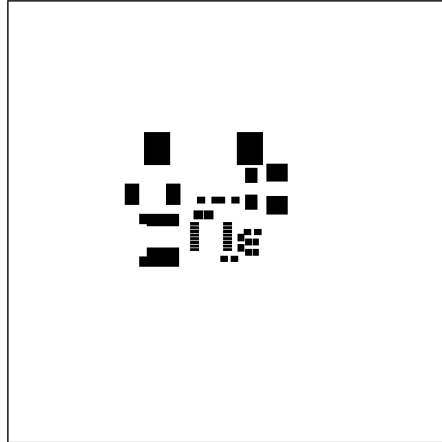

TOP SOLDER PASTE
LINEAR TECHNOLOGY
DC471A-1 * LT3430EFE
2A, 200KHZ HIGH VOLTAGE BUCK CONVERTER

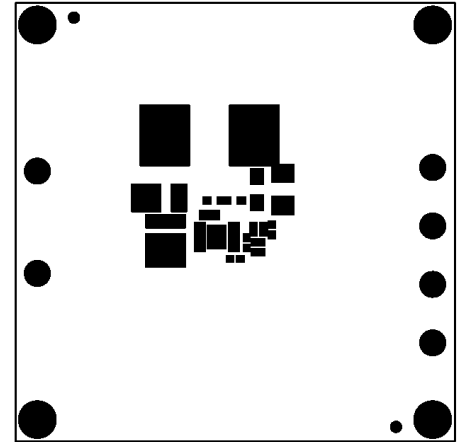

TOP SOLDER MASK
LINEAR TECHNOLOGY
DC471A-1 * LT3430EFE
2A, 200KHZ HIGH VOLTAGE BUCK CONVERTER

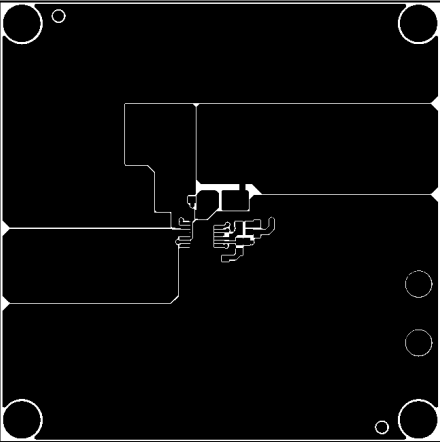

LAYER 1 - TOP LAYER
LINEAR TECHNOLOGY
DC471A-1 * LT3430EFE
2A, 200KHZ HIGH VOLTAGE BUCK CONVERTER

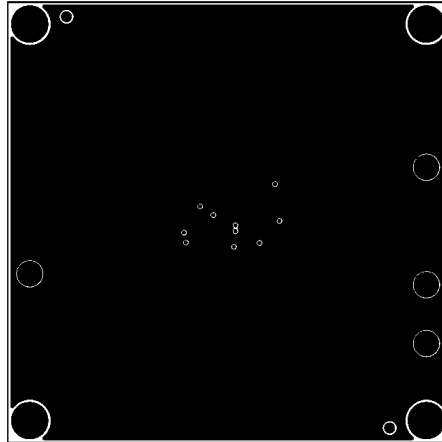

LAYER 2 - GND PLANE
LINEAR TECHNOLOGY
DC471A-1 * LT3430EFE
2A, 200KHZ HIGH VOLTAGE BUCK CONVERTER

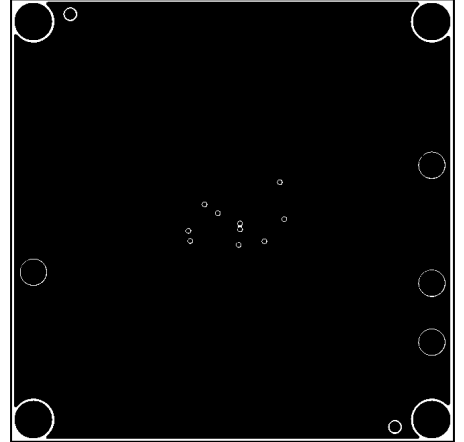

LAYER 3 - GND PLANE
LINEAR TECHNOLOGY
DC471A-1 * LT3430EFE
2A, 200KHZ HIGH VOLTAGE BUCK CONVERTER

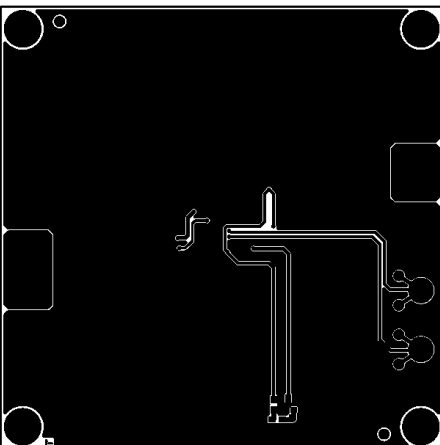

LAYER 4 - BOTTOM LAYER
LINEAR TECHNOLOGY
DC471A-1 * LT3430EFE
2A, 200KHZ HIGH VOLTAGE BUCK CONVERTER

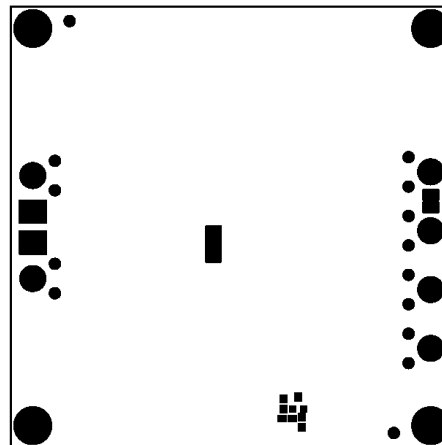

BOTTOM SOLDER MASK
LINEAR TECHNOLOGY
DC471A-1 * LT3430EFE
2A, 200KHZ HIGH VOLTAGE BUCK CONVERTER

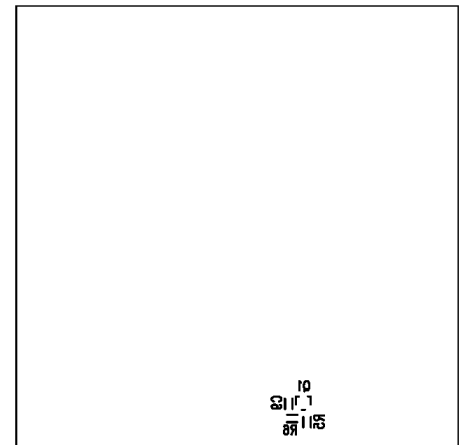

BOTTOM SILKSCREEN
LINEAR TECHNOLOGY
DC471A-1 * LT3430EFE
2A, 200KHZ HIGH VOLTAGE BUCK CONVERTER

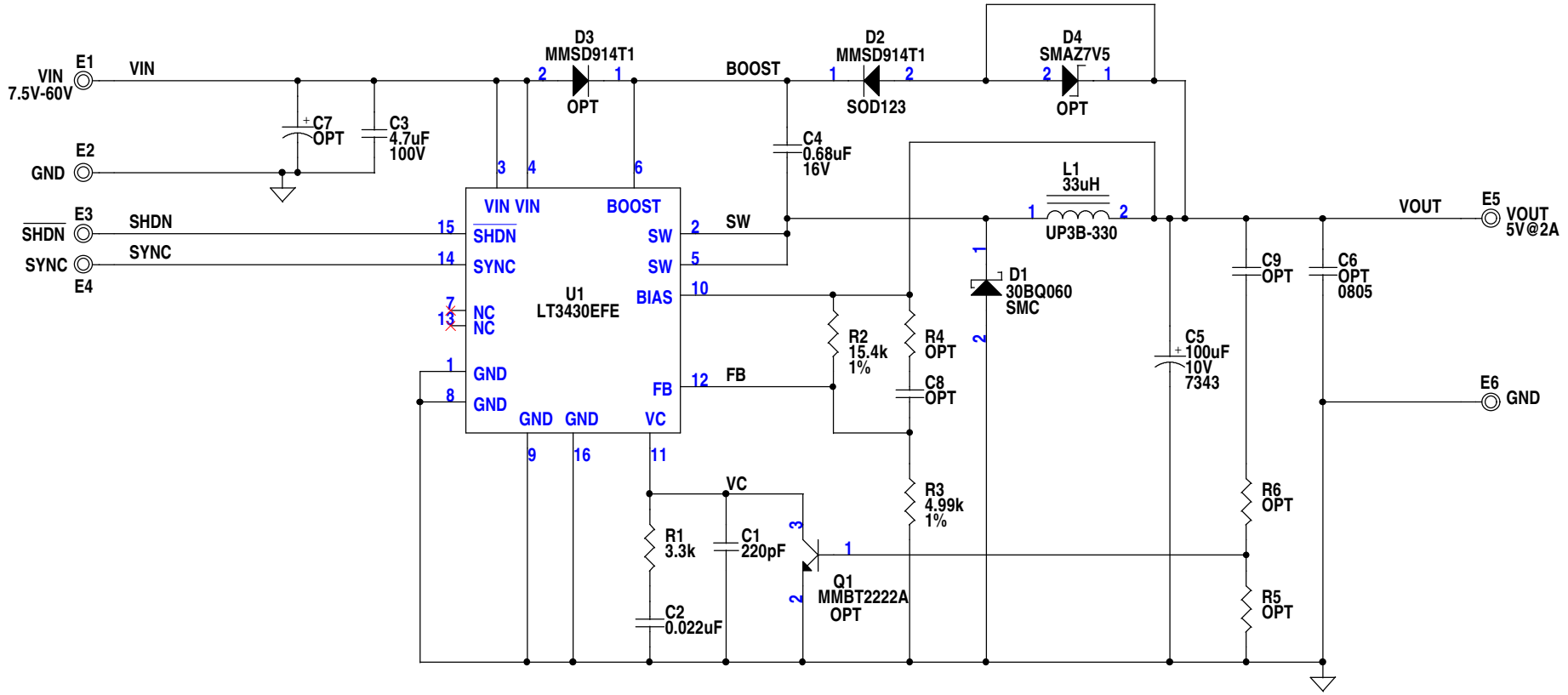

NOTE: UNLESS OTHERWISE SPECIFIED

1. ALL RESISTORS ARE IN OHMS, 0603.
ALL CAPACITORS ARE IN MICROFARADS, 0603.
2. FOR ALL OPTIONAL COMPONENTS ON BOARDS:
Q1, R5, R6, C9: SHOW OUTLINE AND REFERENCE DESIGNATORS.
D3, D4: NO OUTLINE, SHOW REFERENCE DESIGNATORS.
C6, C7, C8, R4: NO OUTLINE, NO REFERENCE DESIGNATORS.

CONTRACT NO.	 1630 McCarthy Blvd. Milpitas, CA 95035 Phone: (408)432-1900 Fax: (408)434-0507 LTC Confidential-For Customer Use Only	
APPROVALS		
DRAWN: KIM T.	TITLE: SCHEMATIC	
CHECKED:	2A, 200kHz HIGH VOLTAGE BUCK CONVERTER	
APPROVED:	SIZE	DWG NO.
ENGINEER: KEITH S.	A	DC471A-1 * LT3430EFE
DESIGNER:	REV	A
	DATE: Wednesday, July 10, 2002	SHEET 1 OF 1

Linear Technology Corporation

LT3430EFE

2A, 200KHz HIGH VOLTAGE BUCK CONVERTER

ENG: KEITH S.

BILL OF MATERIALS

DC471A-1

6/17/2005

12:07 PM

Item	Qty	Reference	Part Description	Manufacture / Part #
1	1	C1	CAP, NPO 220pF 25V 10%	AVX, 06033A221KAT1A
2	1	C2	CAP, X7R 0.022uF 16V 10%	AVX, 0603YC223KAT1A
3	1	C3	CAP, Y5V 4.7uF 100V, 80%, C-THCR60	UNITED CHEMI-CON, THCR60E2A475ZT
4	1	C4	CAP, X7R 0.68uF 16V 20%	TAIYO YUDEN, EMK212BJ684MG
	0	OR	CAP, X5R 1.0uF 16V 10%, 0805	TAIYO YUDEN, EMK212BJ105ZG
5	1	C5	CAP, TANT. 100uF 10V 20%, 7343	AVX, TPSD107M010R0100
6	0	C6	CAP, 0805	OPT
7	0	C7	CAP, C SIZE, 6032	OPT
8	0	C8,C9	CAP, 0603	OPT
9	1	D1	DIODE SCHOTTKY,3A, 60V,SMA-DIODE	IR, 30BQ060
10	1	D2	DIODE, 200mA, 100V, SOD123	ON SEMI., MMSD914T1
11	0	D3	DIODE, 200mA, 100V, SOD123	ON SEMI., MMSD914T1 (OPT)
12	0	D4	DIODE ZENER, SMA-DIODE	DIODES INC., SMAZ7V5 (OPT)
13	6	E1-E6	TP, TURRET, .094"	MILL-MAX, 2501-2
14	1	L1	IND, SMT, 33uH, L-COIL-UP3B	COILTRONICS, UP3B-330
	0	OR	IND, SMT, 47uH, L-COIL-UP4B	COILTRONICS, UP4B-470
15	0	Q1	TRANS, MMBT2222A, SOT23	DIODES INC., MMBT2222A-7 (OPT)
16	1	R1	RES, 3.3k 5%, 0603	AAC, CR16-332JM
17	1	R2	RES, 15.4k 1%, 0603	AAC, CR16-1542FM
18	1	R3	RES, 4.99k 1%, 0603	AAC, CR16-4991FM
19	0	R4,R5,R6	RES, 0603	OPT
20	1	U1	IC, LT3430EFE, TSSOPFE16	LINEAR TECH., LT3430EFE
21	4	MTG HOLES AT 4 CORNERS	STANDOFF, NYLON HEX #4-40 x 1/4"	MICRO PLASTICS, #14HTSP101
22	4		SCREW, #4-40 x 1/4	ANY
NOTES: UNLESS OTHERWISE SPECIFIED				
1. ALL RESISTORS ARE IN OHMS.				
2. INSTALL 4 STANDOFFS AT 4 CORNERS OF BOARD AND ON THE BOTTOM SIDE.				