



Chipsmall Limited consists of a professional team with an average of over 10 year of expertise in the distribution of electronic components. Based in Hongkong, we have already established firm and mutual-benefit business relationships with customers from,Europe,America and south Asia,supplying obsolete and hard-to-find components to meet their specific needs.

With the principle of “Quality Parts,Customers Priority,Honest Operation,and Considerate Service”,our business mainly focus on the distribution of electronic components. Line cards we deal with include Microchip,ALPS,ROHM,Xilinx,Pulse,ON,Everlight and Freescale. Main products comprise IC,Modules,Potentiometer,IC Socket,Relay,Connector.Our parts cover such applications as commercial,industrial, and automotives areas.

We are looking forward to setting up business relationship with you and hope to provide you with the best service and solution. Let us make a better world for our industry!



## Contact us

Tel: +86-755-8981 8866 Fax: +86-755-8427 6832

Email & Skype: info@chipsmall.com Web: www.chipsmall.com

Address: A1208, Overseas Decoration Building, #122 Zhenhua RD., Futian, Shenzhen, China



## DESCRIPTION

Demonstration circuit 547A features the **LTC1864L** 16-bit 150ksps analog-to-digital converter.

This board provides a means to evaluate the performance of the LTC1864L with either the Linear Technology PScope™ data acquisition system, or with other parallel or serial data acquisition systems.

The board also demonstrates proper layout techniques in the circuitry surrounding the ADC and in the segmentation of the planes required to achieve full performance with the ADC.

These techniques include proper grounding of the device and associated bypass capacitors, placement of the device relative to interconnection of analog and digital subsystems and signal routing in proximity to the ADC.

This board performs serial to parallel conversion in a manner that is unlikely to be used in an actual implementation, but is representative of what could be implemented in an FPGA. It is expected that with this ADC, the interface will be performed serially with either programmable logic, a general-purpose processor, a DSP, or across an isolated link of one of many types. The complexity of the circuitry

is hence much greater than what would be required in almost any practical application.

The LTC1864L and its demo board are intended to be used with the PScope data acquisition system for characterization of the ADC in AC applications extending from DC to 1.5MHz. The full power bandwidth of the LTC1864L is high enough to produce good performance in under-sampling applications, as well as applications where the signal content is below Nyquist.

The board contains a bandwidth-limiting filter at the input of the ADC (C7, C8, C9, R1 and R2), as well as provision for an amplifier (U2). This bandwidth-limiting filter (–3dB at 1.5MHz) is typical of what may be required for many applications, but it is not necessarily the best for all applications.

The board also incorporates an LTC1799 resistor programmable oscillator as an optional clock source.

**Design files for this circuit board are available at <http://www.linear.com/demo/DC547A>**

LT, LT, LTC, LTM, Linear Technology and the Linear logo are registered trademarks and PScope is a trademark of Linear Technology Corporation. All other trademarks are the property of their respective owners.

---

## QUICK START PROCEDURE

Demonstration circuit 547A is easy to set up to evaluate the performance of the LTC1864L. Refer to Figure 1 for proper measurement equipment setup and follow the procedure below:

NOTE: The demo board is shipped with jumpers in place to allow the use of an external oscillator at 64× the sample rate. Figure 1 shows the default jumper positions.

1. Connect the parallel output Pins 1-40 to either the DC718 data collection board, or to a suitable acquisition system. Pin 3 is the data strobe.

2. Observe correct polarity; Connect +8V to +15V to the +15V terminal. Note that –15V is only required if U2 is installed. There are two on board regulators. U1, the reference voltage is 2.5V. U11 at 3.3V, provides power to the board. If the intent is to do an evaluation of AC performance, connect a sinusoidal (or other) input signal to J1, or J1 and J2. If only J1 is used (single-ended operation), JP3 should be connected to GND. This converter converts unipolar differential inputs from  $0 - V_{REF}$ .

## QUICK START PROCEDURE

NOTE: The  $A_{IN}$  inputs do not have  $50\Omega$  termination. Most generators will produce the correct signal level only if the cable is terminated at  $50\Omega$ . If you are driving this from a generator, you should use  $50\Omega$  through terminators. Take care not to overdrive the inputs if you do not use terminators.

3. Connect an 8MHz digital clock to CLKIN. With default jumpers in place, this will result in a 125ksps conversion rate.
4. Collect data via PScope for a Fourier Transform into the frequency domain, or to allow data to be collected and saved to a file for subsequent import and analysis in Excel, Matlab or other analysis packages.

Duplication of the FFT results shown in the data sheet requires the use of a low jitter clock and waveform generators synchronized such that the input waveform must be within a few ppm of an exact multiple of the conversion clock divided by the FFT size (termed coherent). For 125kHz sample rate and a 4096 point FFT, input frequencies should be an exact multiple of 30.51757813Hz, and preferably a prime number multiple or at least an odd number multiple. The use of an even number multiple will exercise a minimal number of codes, producing poor results.

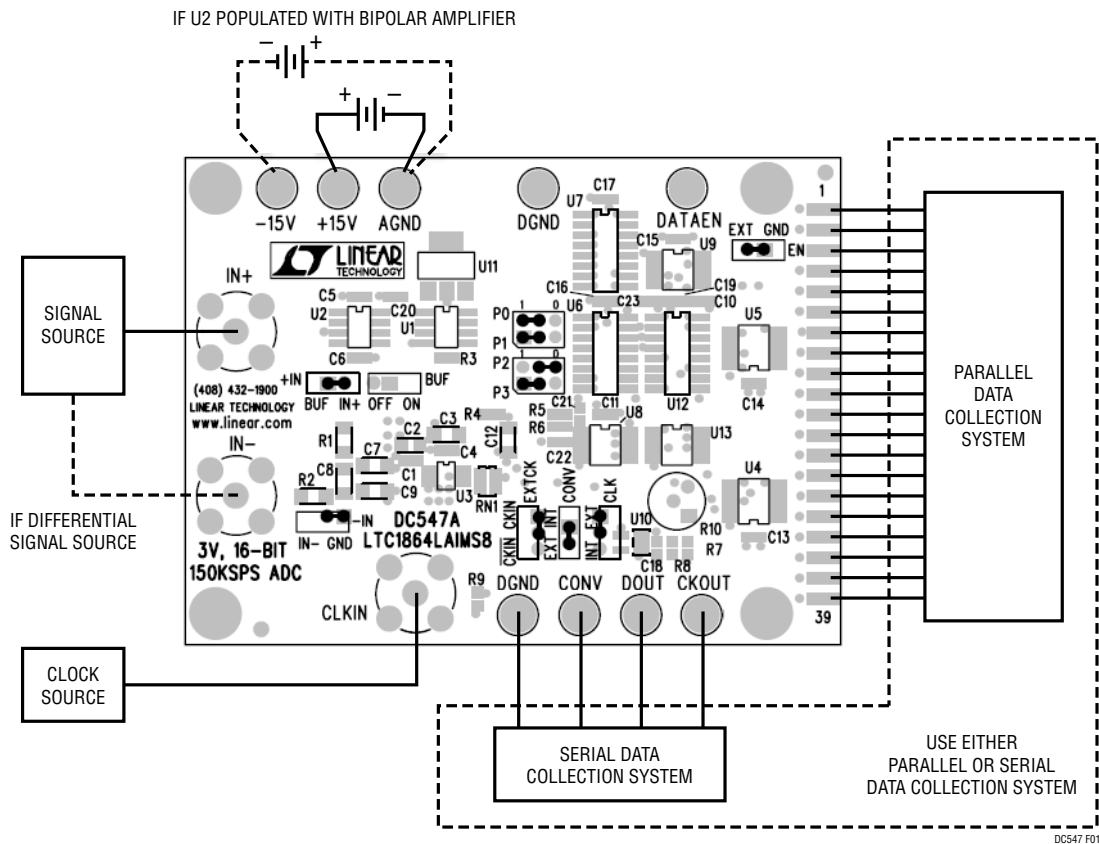

Figure 1. Proper Measurement Equipment Setup

## OPERATION

The conversion clock (CONV) is derived from the CLKIN connector (J3) via a programmable divider.

The board is shipped with this divider set to divide by 64 (P0-P3). In order for this board to achieve its maximum throughput with this jumper setting, of 125ksps, requires that the SCLK be at 8MHz.

The programmable divider can be strapped for different divide ratios if the required sample rate is less than 125ksps, allowing a greater percentage of the time available doing data transfer (divide ratio of less than 64), or if a comparable SCLK rate is used, with a lower sample rate (divide ratio greater than 64).

P0-P3 are set to code 11 (divide ratio/64) by default. The range is 16 to 240 in increments of 16. Higher codes produce lower ratios.

### Ratio = (15-Code) • 16

To achieve the part's maximum sample rate of 150ksps set P0-P3 to 12 (divide ratio/48) and SCLK to 7.2MHz.

The counter circuitry gates a sequence of 16 clock pulses during CONV = 0. These can be observed on CKOUT, or if CONV is introduced externally, (set CONV to EXT) the clock pulses can be introduced via CLKIN (CLK to EXT, EXT CLK to CKIN if no inversion is required).

Setting CLK to INT allows the use of the onboard LTC1799 oscillator. Note that this oscillator will not produce data sheet performance unless the input frequency is quite low, as the phase jitter of this oscillator will be transformed in the presence of high slew rate signals into random noise. If the amplitude of the signal falls off with increasing frequency as many natural phenomena do, this oscillator may produce acceptable results.

If you are undersampling, or operating the converter near Nyquist, it is important to have a low jitter clock source.

The data output DOUT is shifted into a pair of 74HC595 serial to parallel shift registers that have output holding registers, and tri-state outputs. If you intend to incorporate the demo board into a prototype of a system, ENABLE-DATA can be used to gate the outputs onto a 16-bit bus. Alternatively, all of the signals can be produced externally, and data can be read into a DSP via DOUT.

If you elect to use the on-board timing to clock data into a slaved serial input port, you can use DOUT, CKOUT, along with CONV as a busy signal or as a means of producing a frame sync.

In the event that you do not have "coherent" signal sources as described above, you can use windowing functions to reduce the "leakage" effect that occurs in the Fourier transform and get a reasonably accurate figure for SNR, THD, SINAD and the levels of the various harmonics.

# DEMO MANUAL DC547A

## PARTS LIST

ITEM	QTY	REFERENCE	PART DESCRIPTION	MANUFACTURER/PART NUMBER
<b>Required Circuit Components</b>				
1	15	C1, C4-C6, C10, C11, C13-C20, C23	CAP., X7R, 0.1µF, 16V	AVX, 0603YC104MAT1A
2	1	C2	CAP., X7R, 1µF, 10V, 20%	AVX, 0805ZC105MAT1T
3	2	C3, C12	CAP., X5R, 10µF, 6.3V, 20%, 1206	TAIYO YUDEN JMK316BJ106MLT
4	2	C7, C9	CAP., NPO, 100PF, 50V, 1206	VITRAMON, VJ1206A101JXA
5	1	C8	CAP., NPO, 470PF, 100V,1206	AVX, 12061A471JAT
6	2	C21, C22	CAP., NPO, 47PF, 50V	AVX, 06035A470MAT1A
7	9	E1-E9	TP, TURRET, .094"	MILL-MAX, 2501-2
8	7	JP1-JP7	JMP, 1 × 3, .079CC	COMM-CON, 2802S-03-G1
9	2	JP8, JP9	JMP, 2 × 3, .079CC	COMM CON, 2202S-06-G2
10	9	SHUNTS FOR JP1-JP9	SHUNT, .079" CENTER	COMM-CON, CCIJ2MM-138G
11	3	J1-J3	CONN, BNC 50Ω, PCB-VERTICADTL	CONNEX, 112404
12	1	J4	CON, HDR, .1 × .1 CNTRS, 40PIN	COMMCON, 3201S-40G1
13	1	RN1	RES, 2 × 4 ARRAY, CHIP, 330Ω, ISO	CTS, 742-C083-331JTR-ND
14	2	R1, R2	RES, CHIP 100, 1/16W, 5%,1206	AAC, CR18-101JM
15	2	R3, R4	RES, CHIP 2, 1/16W, 5%, 0603	AAC, CR16-2R0JM
16	2	R5, R6	RES, CHIP 402, 1/16W, 1%, 0603	AAC, CR16-4020FM
17	1	R7	RES, CHIP 20k, 1/16W, 5%, 0603	AAC, CR16-203JM
18	1	R8	RES, CHIP 1M, 1/16W, 5%, 0603	AAC, CR16-105JM
19	1	R9	RES, CHIP 51, 1/16W, 5%, 0603	AAC, CR16-510JM
20	1	R10	RES, POT3321H, POT-3321H-MURATA	MURATA, PV32H103A01B00
21	1	U1	IC, LT1460DCS8-2.5, S08	LINEAR TECH., LT1460DCS8-2.5
22	1	U2	IC, OP AMP, S08	TBD
23	1	U3	IC, LTC1864LAIMS8, MSOP8	LINEAR TECH., LTC1864LAIMS8
24	2	U4, U5	IC, MC74HC595ADT, TSSOP16	MOTOROLA, MC74HC595ADT
25	2	U6, U7	IC, MC74HC163AD, S016	MOTOROLA, MC74HC163AD
26	1	U8	IC, MC74AC14DTR2, TSSOP14	ON SEMI., MC74AC14DTR2
27	1	U9	IC, MC74AC00DTR2, TSSOP14	ON SEMI., MC74AC00DTR2
28	1	U10	IC, LTC1799CS5, SOT23-5	LINEAR TECH., LTC1799CS5
29	1	U11	IC, LT1121CST-3.3, SOT223	LINEAR TECH., LT1121CST-3.3
30	1	U12	IC, MC74AC109DR2, S016	ON SEMI., MC74AC109DR2
31	1	U13	IC, MC74AC32DTR2, TSSOP14	ON SEMI., MC74AC32DTR2
32	4	MTGS AT 4 CORNERS	SCREW, #4-40, 1/4"	ANY
33	4	MTGS AT 4 CORNERS	STANDOFF, NYLON HEX #4-40 1/2"	MICRO PLASTICS 14HTSP003

NOTES: UNLESS OTHERWISE SPECIFIED

1. ALL RESISTORS ARE IN OHMS.

2. INSTALL SHUNTS ON JP1,JP3-JP7 PIN 1 AND 2; ON JP2 PIN 2 AND 3;  
ON JP8 PIN 1 AND 3, PIN 2 AND 4; ON JP9 PIN 1 AND 3, PIN 4 AND 6.

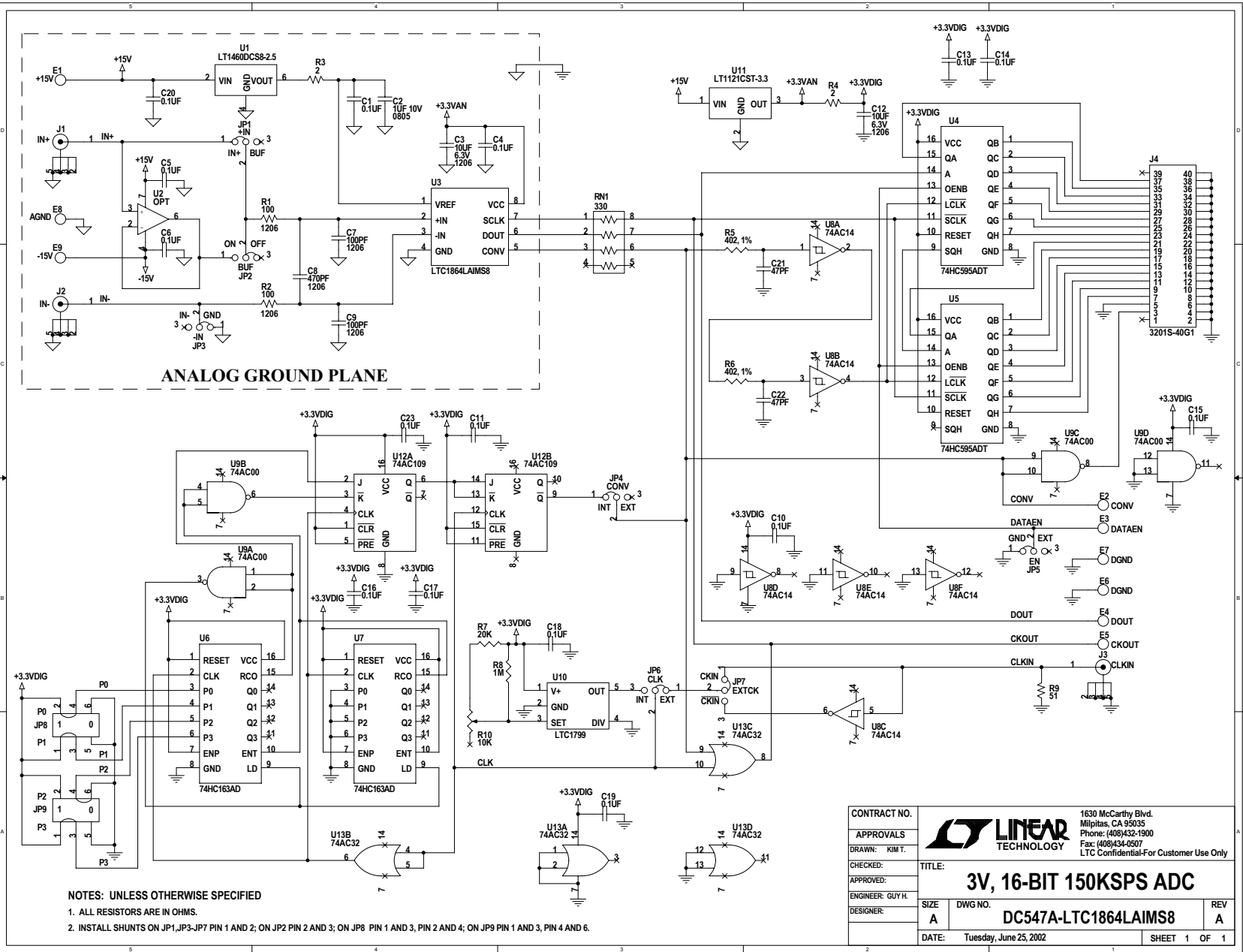

CONTRACT NO.			1630 McCarthy Blvd. Milpitas, CA 95035 Phone: (408)432-1900 Fax: (408)434-0507 LTC Confidential-For Customer Use Only
APPROVALS			
DRAWN: KIM T.	TITLE: <b>3V, 16-BIT 150KSPS ADC</b>		
CHECKED:	SIZE	DWG NO.	REV
APPROVED:	A	DC547A-LTC1864LAIMS8	A
ENGINEER: GUY H.	DATE: Tuesday, June 25, 2002		
DESIGNER:	SHEET 1		OF 1

# DEMO MANUAL DC547A

---

## DEMONSTRATION BOARD IMPORTANT NOTICE

Linear Technology Corporation (LTC) provides the enclosed product(s) under the following **AS IS** conditions:

This demonstration board (DEMO BOARD) kit being sold or provided by Linear Technology is intended for use for **ENGINEERING DEVELOPMENT OR EVALUATION PURPOSES ONLY** and is not provided by LTC for commercial use. As such, the DEMO BOARD herein may not be complete in terms of required design-, marketing-, and/or manufacturing-related protective considerations, including but not limited to product safety measures typically found in finished commercial goods. As a prototype, this product does not fall within the scope of the European Union directive on electromagnetic compatibility and therefore may or may not meet the technical requirements of the directive, or other regulations.

If this evaluation kit does not meet the specifications recited in the DEMO BOARD manual the kit may be returned within 30 days from the date of delivery for a full refund. **THE FOREGOING WARRANTY IS THE EXCLUSIVE WARRANTY MADE BY THE SELLER TO BUYER AND IS IN LIEU OF ALL OTHER WARRANTIES, EXPRESSED, IMPLIED, OR STATUTORY, INCLUDING ANY WARRANTY OF MERCHANTABILITY OR FITNESS FOR ANY PARTICULAR PURPOSE. EXCEPT TO THE EXTENT OF THIS INDEMNITY, NEITHER PARTY SHALL BE LIABLE TO THE OTHER FOR ANY INDIRECT, SPECIAL, INCIDENTAL, OR CONSEQUENTIAL DAMAGES.**

The user assumes all responsibility and liability for proper and safe handling of the goods. Further, the user releases LTC from all claims arising from the handling or use of the goods. Due to the open construction of the product, it is the user's responsibility to take any and all appropriate precautions with regard to electrostatic discharge. Also be aware that the products herein may not be regulatory compliant or agency certified (FCC, UL, CE, etc.).

No License is granted under any patent right or other intellectual property whatsoever. **LTC assumes no liability for applications assistance, customer product design, software performance, or infringement of patents or any other intellectual property rights of any kind.**

LTC currently services a variety of customers for products around the world, and therefore this transaction **is not exclusive**.

**Please read the DEMO BOARD manual prior to handling the product.** Persons handling this product must have electronics training and observe good laboratory practice standards. **Common sense is encouraged.**

This notice contains important safety information about temperatures and voltages. For further safety concerns, please contact a LTC application engineer.

Mailing Address:

Linear Technology  
1630 McCarthy Blvd.  
Milpitas, CA 95035

Copyright © 2004, Linear Technology Corporation