



Chipsmall Limited consists of a professional team with an average of over 10 year of expertise in the distribution of electronic components. Based in Hongkong, we have already established firm and mutual-benefit business relationships with customers from,Europe,America and south Asia,supplying obsolete and hard-to-find components to meet their specific needs.

With the principle of “Quality Parts,Customers Priority,Honest Operation,and Considerate Service”,our business mainly focus on the distribution of electronic components. Line cards we deal with include Microchip,ALPS,ROHM,Xilinx,Pulse,ON,Everlight and Freescale. Main products comprise IC,Modules,Potentiometer,IC Socket,Relay,Connector.Our parts cover such applications as commercial,industrial, and automotives areas.

We are looking forward to setting up business relationship with you and hope to provide you with the best service and solution. Let us make a better world for our industry!



## Contact us

Tel: +86-755-8981 8866 Fax: +86-755-8427 6832

Email & Skype: info@chipsmall.com Web: www.chipsmall.com

Address: A1208, Overseas Decoration Building, #122 Zhenhua RD., Futian, Shenzhen, China



# LTC2418

## 8-/16-Channel Differential 24-Bit $\Delta\Sigma$ ADC

### DESCRIPTION

The LTC<sup>®</sup>2418 is a high resolution, 24-bit  $\Delta\Sigma$  ADC with 5ppm INL and 5 $\mu$ V offset. Channel selection is programmed through a simple serial interface. Since there is no latency, each conversion is valid, even after a change in input channel.

DC571A is a member of Linear Technology's QuikEval<sup>™</sup> family of demonstration boards.

It is designed to allow easy evaluation of the LTC2418 and may be connected directly to the target application's analog

signals while using the DC590 USB serial controller board and supplied software to measure performance.

After evaluating with LTC's software, the digital signals can be connected to the application's processor/controller for development of the serial interface.

**Design files for this circuit board are available at <http://www.linear.com/demo>**

LT, LT, LTC, LTM, Linear Technology and the Linear logo are registered trademarks and QuikEval is a trademark of Linear Technology Corporation. All other trademarks are the property of their respective owners.

### QUICK START PROCEDURE

Connect DC571 to DC590 USB serial controller using the supplied 14-conductor ribbon cable. Connect DC590 to host PC with a standard USB A/B cable. Run the evaluation software supplied with DC590 or downloaded from [www.linear.com/software](http://www.linear.com/software). The correct program will be loaded automatically.

Click the COLLECT button to start reading the input voltage. Click the slider at the bottom of the strip-chart display to change the input channel being displayed. For differential measurements, Even channel pos and odd channel pos correspond to even channels being positive inputs or odd channels being positive inputs, respectively. See the LTC2418 data sheet for details of channel selection.

Tools are available for logging data, changing reference voltage, changing the number of points in the strip-chart and histogram, and changing the number of points averaged for the DVM display.

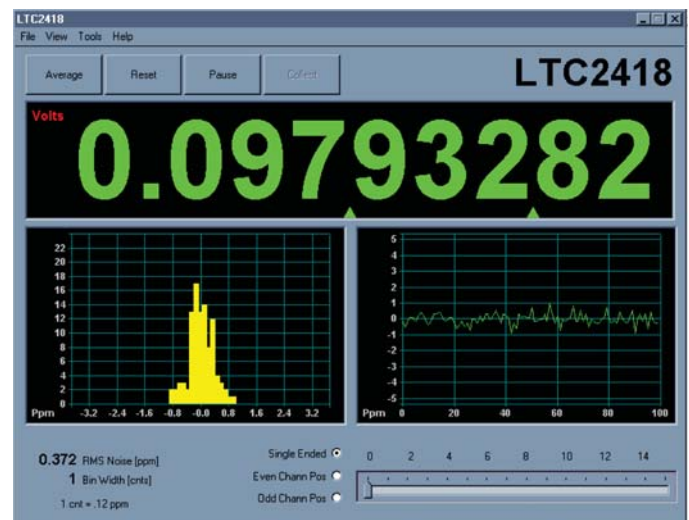

Figure 1. DC590 Program

## HARDWARE SETUP

### JUMPERS

**JP1:** Select the connection for the common pin, either ground or external connection. Single-ended measurements are taken with respect to this pin.

**JP2 and JP3:** Select the source for differential reference. Selecting 5V and GND will use the onboard 5V reference. Select EXT to use an external reference.

**JP5:** Select notch frequency, 60Hz or 50Hz. Alternatively, this jumper may be removed and an external conversion clock applied to the center pin of JP5.

---

## EXPERIMENTS

Figure 2 shows a number of applications for the LTC2418.

### CH0, CH1, CH2

Channels 0 and 1 measure the differential output of an Intersema MS5401 absolute pressure sensor. The 6.8k resistor performs a first order temperature compensation of the bridge output. CH2 measures the bridge voltage, which provides a convenient temperature measurement. This can also be used to perform further temperature compensation in software.

### CH3

Channel 3 measures the output of a thermistor in a half bridge circuit. Many thermistors will work, the constraints are that the bridge output must have an impedance of less than 20k and the voltage must not go above  $V_{REF}/2$ .

### CH4

Channel 4 measures the output of a type J thermocouple. The circuit shown for channel 3 can be used for cold junction compensation. The cold junction sensor should be close to the connections of the thermocouple to the board.

### CH5

Channel 5 measures the output of an Omega OS36-01 infrared thermocouple. This can be used for remote temperature measurement.

### CH6

Channel 6 measures the photocurrent of a Hamamatsu S1336-5BK photodiode.

### CONNECTION TO DC590 SERIAL CONTROLLER

J1 is the power and digital interface connector. Connect to DC590 serial controller with supplied 14-conductor ribbon cable.

### ANALOG CONNECTIONS

Analog signal connections are made via the turret posts along the edge of the board (CH0 to CH15.) Also, if you are connecting the board to an existing circuit, make full use of the four ground connections at the corners of the board.

### CH7

Channel 7 measures the output of a resistive attenuator.

### CH8, CH9

Channels 8 and 9 measure the drop across a Deltec SWE-3000-50 current shunt. Up to 3000A can be measured, with a resolution of 60mA. With careful grounding, both positive and negative currents can be measured. Care must be taken to ensure that both inputs stay more positive than GND-0.3V.

### CH10

Channel 10 is buffered with an LT1793 FET input amplifier suitable for very high source impedance measurements.

### CH11

Channel 11 measures the output of a precision rectifier.

### CH12, CH13

Channels 12 and 13 measure a 3-wire RTD. The differential voltage is the output, and CH12 single-ended reading is the ground lead compensation.

### CH14, CH15

Channels 14 and 15 measure the output of a 350Ω bridge. This is standard for a wide variety of sensors. Typically the full-scale output voltage is only 10mV. However, the LTC2418 still gives 13 effective bits of resolution with no amplification.

EXPERIMENTS

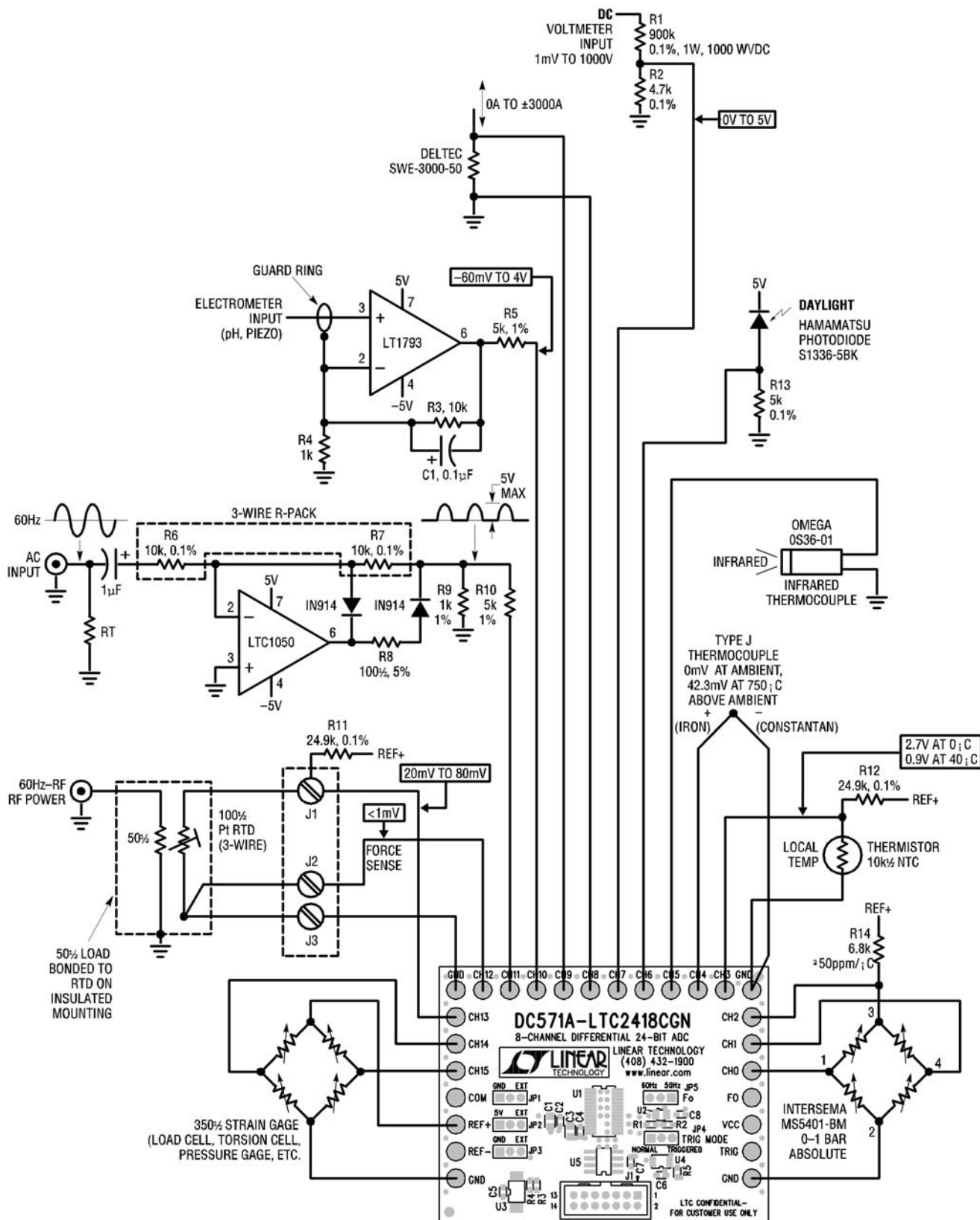
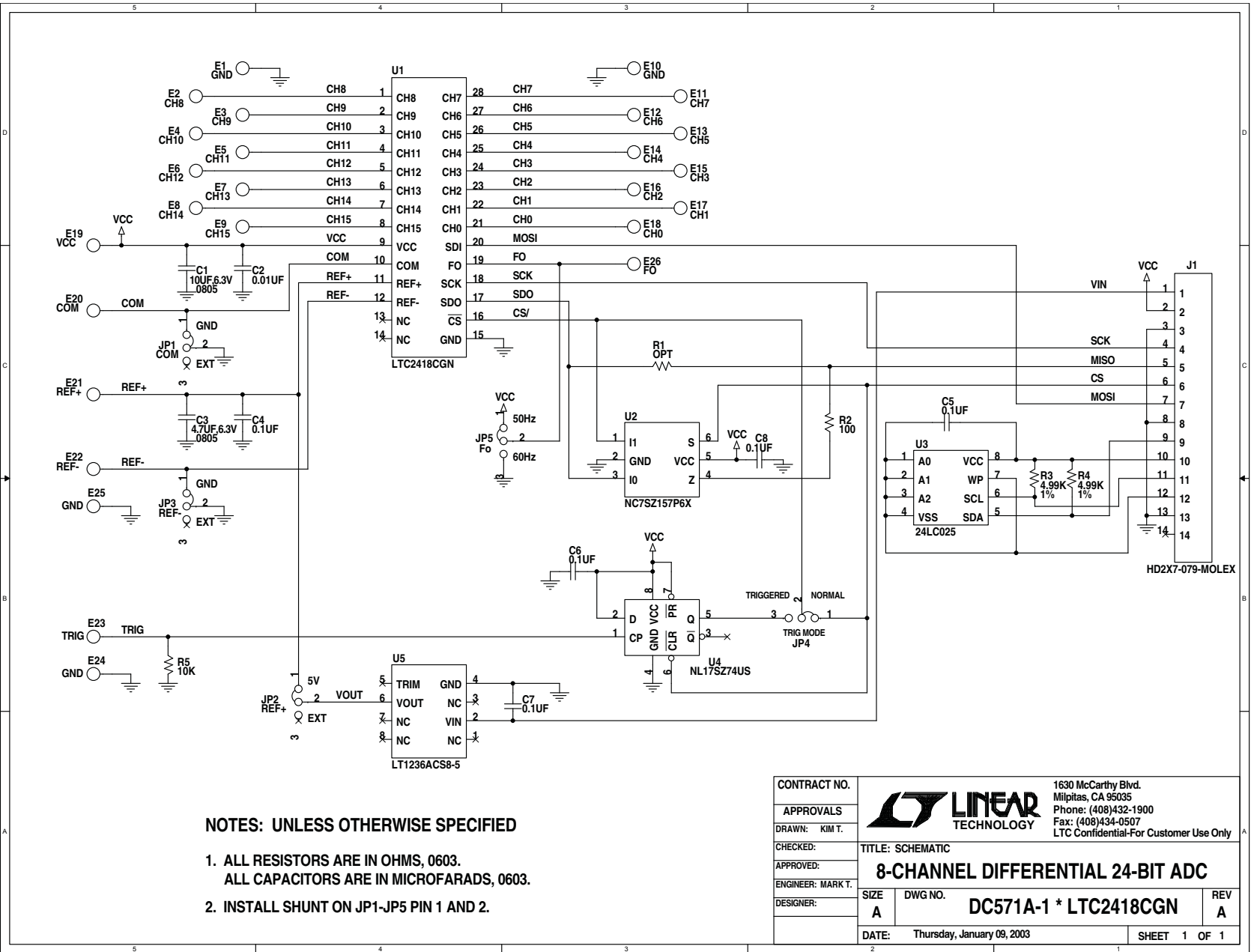



Figure 2. LTC2418 Applications

# DEMO MANUAL DC571A

## PARTS LIST

ITEM	QTY	REFERENCE	PART DESCRIPTION	MANUFACTURER/PART NUMBER
1	1	C1	CAP, X5R, 10 $\mu$ F 6.3V, 20%, 0805	TDK, C2012X5R0J106M
2	1	C2	CAP, X7R 0.01 $\mu$ F 16V 10%, 0603	AVX, 0603YC103KAT1A
3	1	C3	CAP, X5R 4.7 $\mu$ F 6.3V, 20%, 0805	TAIYO YUDEN, JMK212BJ475MGT
4	5	C4, C5, C6, C7, C8	CAP, X7R 0.1 $\mu$ F 16V, 0603	AVX, 0603YC104MAT1A
5	26	E1 TO E26	TESTPOINT, TURRET, 0.064"	MILL-MAX, 2308-2
6	5	JP1, JP2, JP3, JP4, JP5	JMP, 3PIN 1 ROW 0.079CC	COMM-CON, 2802S-03-G1
7	5	SHUNTS FOR JP1 TO JP5	SHUNT, 0.079" CENTER	COMM-CON CCIJ2MM-138G
8	1	J1	HEADER, 2 x 7PIN, 0.079CC	MOLEX, 87331-1420
9	0	R1	RES, 0606	OPT
10	1	R2	RES, CHIP 100 1/16W 5%, 0603	AAC, CR16-101JM
11	2	R4, R3	RES, CHIP 4.99k 1/16W 1%, 0603	AAC, CR16-4991FM
12	1	R5	RES, CHIP 10k 1/16W 5%, 0603	AAC, CR16-103JM
13	1	U1	IC, LTC2418CGN, SSOP16GN	LINEAR TECHNOLOGY, LTC2418CGN
14	1	U2	IC, NC7SZ157P6X, SC70-6P	FAIRCHILD SEMI, NC7SZ157P6X
15	1	U3	IC, 24LC025, TSSOP-8	MICROCHIP, 24LC025-I /ST
16	1	U4	IC, NL17SZ74US, US8	ON SEMI, NL17SZ74US
17	1	U5	IC, LT1236ACS8-5, SO8	LINEAR TECHNOLOGY, LT1236ACS8-5



CONTRACT NO.			1630 McCarthy Blvd. Milpitas, CA 95035	
APPROVALS			Phone: (408)432-1900 Fax: (408)434-0507 LTC Confidential-For Customer Use Only	
DRAWN: KIM T.	TITLE: SCHEMATIC			
CHECKED:	<b>8-CHANNEL DIFFERENTIAL 24-BIT ADC</b>			
APPROVED:	SIZE	DWG NO.	REV	
ENGINEER: MARK T.	A	DC571A-1 * LTC2418CGN	A	
DESIGNER:	DATE: Thursday, January 09, 2003		SHEET 1 OF 1	

# DEMO MANUAL DC571A

---

## DEMONSTRATION BOARD IMPORTANT NOTICE

Linear Technology Corporation (LTC) provides the enclosed product(s) under the following **AS IS** conditions:

This demonstration board (DEMO BOARD) kit being sold or provided by Linear Technology is intended for use for **ENGINEERING DEVELOPMENT OR EVALUATION PURPOSES ONLY** and is not provided by LTC for commercial use. As such, the DEMO BOARD herein may not be complete in terms of required design-, marketing-, and/or manufacturing-related protective considerations, including but not limited to product safety measures typically found in finished commercial goods. As a prototype, this product does not fall within the scope of the European Union directive on electromagnetic compatibility and therefore may or may not meet the technical requirements of the directive, or other regulations.

If this evaluation kit does not meet the specifications recited in the DEMO BOARD manual the kit may be returned within 30 days from the date of delivery for a full refund. **THE FOREGOING WARRANTY IS THE EXCLUSIVE WARRANTY MADE BY THE SELLER TO BUYER AND IS IN LIEU OF ALL OTHER WARRANTIES, EXPRESSED, IMPLIED, OR STATUTORY, INCLUDING ANY WARRANTY OF MERCHANTABILITY OR FITNESS FOR ANY PARTICULAR PURPOSE. EXCEPT TO THE EXTENT OF THIS INDEMNITY, NEITHER PARTY SHALL BE LIABLE TO THE OTHER FOR ANY INDIRECT, SPECIAL, INCIDENTAL, OR CONSEQUENTIAL DAMAGES.**

The user assumes all responsibility and liability for proper and safe handling of the goods. Further, the user releases LTC from all claims arising from the handling or use of the goods. Due to the open construction of the product, it is the user's responsibility to take any and all appropriate precautions with regard to electrostatic discharge. Also be aware that the products herein may not be regulatory compliant or agency certified (FCC, UL, CE, etc.).

No License is granted under any patent right or other intellectual property whatsoever. **LTC assumes no liability for applications assistance, customer product design, software performance, or infringement of patents or any other intellectual property rights of any kind.**

LTC currently services a variety of customers for products around the world, and therefore this transaction **is not exclusive**.

**Please read the DEMO BOARD manual prior to handling the product.** Persons handling this product must have electronics training and observe good laboratory practice standards. **Common sense is encouraged.**

This notice contains important safety information about temperatures and voltages. For further safety concerns, please contact a LTC application engineer.

Mailing Address:

Linear Technology  
1630 McCarthy Blvd.  
Milpitas, CA 95035

Copyright © 2004, Linear Technology Corporation