



Chipsmall Limited consists of a professional team with an average of over 10 year of expertise in the distribution of electronic components. Based in Hongkong, we have already established firm and mutual-benefit business relationships with customers from,Europe,America and south Asia,supplying obsolete and hard-to-find components to meet their specific needs.

With the principle of "Quality Parts,Customers Priority,Honest Operation,and Considerate Service",our business mainly focus on the distribution of electronic components. Line cards we deal with include Microchip,ALPS,ROHM,Xilinx,Pulse,ON,Everlight and Freescale. Main products comprise IC,Modules,Potentiometer,IC Socket,Relay,Connector.Our parts cover such applications as commercial,industrial, and automotives areas.

We are looking forward to setting up business relationship with you and hope to provide you with the best service and solution. Let us make a better world for our industry!



Contact us

Tel: +86-755-8981 8866 Fax: +86-755-8427 6832

Email & Skype: info@chipsmall.com Web: www.chipsmall.com

Address: A1208, Overseas Decoration Building, #122 Zhenhua RD., Futian, Shenzhen, China



DESCRIPTION

Demonstration circuit 629 is a multi-display LED controller featuring the LTC3205.

The LTC3205 is a highly integrated multi-display LED controller. This device contains a high efficiency, low noise fractional step-up/step-down charge pump to provide power for a main and sub white LED display, plus an RGB color LED display. The LTC3205 requires only four small ceramic capacitors plus two resistors to form a complete 3-panel LED power supply and a current controller.

Maximum currents for the main/sub and RGB displays are set independently with a single resistor. Current for each LED is controlled with an internal current source.

Dimming and ON/OFF control for all displays is achieved via a 3-wire serial interface. Four dimming states exist for the main and sub panel displays and 16 dimming states are available via internal PWM for the red, green, and blue LEDs resulting in up to 4096 color combinations.

The LTC3205 charge pump optimizes efficiency based on V_{IN} and LED forward voltage conditions. The part powers up in step-down mode and automatically switches to step-up mode once the first LED current source begins to enter dropout. Internal circuitry prevents inrush current and excess input noise during start-up and mode switching.

QUICK START PROCEDURE

Demonstration circuit 629 is easy to set up to evaluate the performance of the LTC3205. Refer to Figure 1 for proper measurement equipment setup and follow the procedure below:

1. Connect DC629 to the DC590 USB Serial Controller using the supplied 14-conductor ribbon cable as shown in Figure 1. Refer to the DC590 Quick Start guide for software installation details.
2. Attach the supplied USB cable into your computer and then into the DC590 controller board.

3. Run the QuickEval™ program. The program detects the DC629 and displays the LTC3205 control window (shown in Figure 2).
4. Attach a 2.7V–4.5V power source to the V_{IN} and GND turrets of the DC629 demo board. This is the V_{IN} power supply for the LTC3205 (see attached schematic).

NOTE: The LTC3205's maximum current settings for Main, Sub, and RGB are set by R2 and R3 (see the attached DC629 schematic.) $R2 = R3 = 32.4k$, which set the maximum current to 15mA.

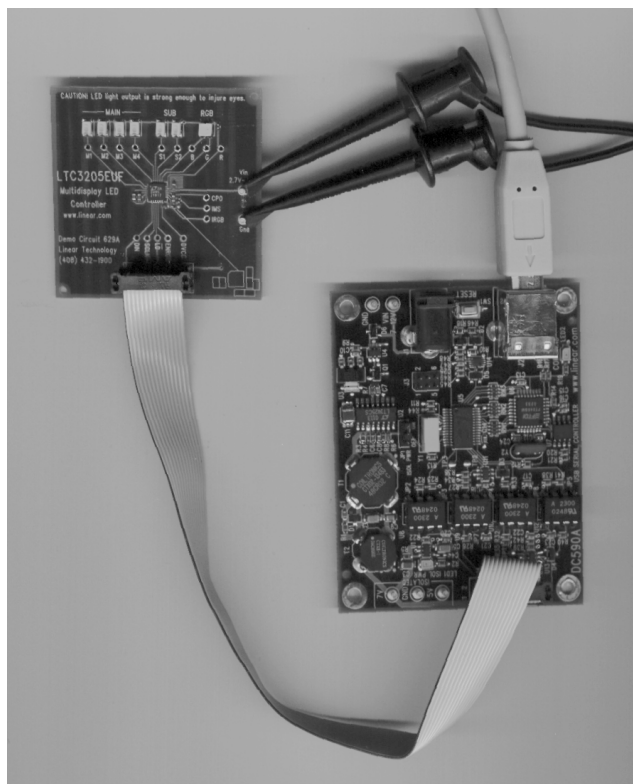

Figure 1. Proper Measurement Equipment Setup

USING THE LTC3205 QUICKVAL SOFTWARE

The program provides brightness controls for the Main, Sub, and RGB LEDs, an OFF/ON button which controls output to the DC629 demo board, three demo buttons, and a CIE Chromaticity diagram which allows direct selection of colors.

OFF/ON — Click this button to begin outputting data to the LTC3205. The default state is **OFF**. The 16-bit hex code transmitted to the LTC3205 is shown in the **HEX OUT** box when this button is on.

MAIN and SUB control — These are vertical slide controls which adjust the main and sub LED output from 0 to 100% by clicking on the up and down arrows, a higher or lower tick, or by clicking and dragging the slide pointer.

RED, GREEN, and BLUE controls — These are horizontal slide controls which allow individual adjustment of

the red, green, and blue LEDs to make any of the 4096 colors available. The hex code and color are displayed in small boxes to the right of each slider. They too are adjusted by clicking on the left and right arrows, a higher or lower tick, or by clicking and dragging the slide pointer.

CIE Chromaticity diagram — Colors can be selected by clicking on a specific color in the diagram. The Gamut box, when checked, displays the Chromaticity coordinates of the Nichia NSCM315C RGB diode forming a triangle or *gamut* of all the colors which can be produced by that diode.

BRIGHTNESS — This is a horizontal slider used to adjust the intensity of a color that has been chosen. It is also adjusted by clicking on the left and right arrows, a

QUICK START GUIDE FOR DEMONSTRATION CIRCUIT 629

MULTI-DISPLAY LED CONTROLLER

higher or lower tick or by clicking and dragging the slide pointer.

DEMO 1, 2, and 3 – These buttons can be selected to run 3 different demonstrations. The OFF/ON button must be **ON** to see the demonstrations.

Quick Start Guide, LTC3205 Data Sheet – These buttons will open this document and the LTC3205 data sheet, respectively. This requires Adobe Acrobat reader and either an internet connection or copies of these documents in the local documentation directory.

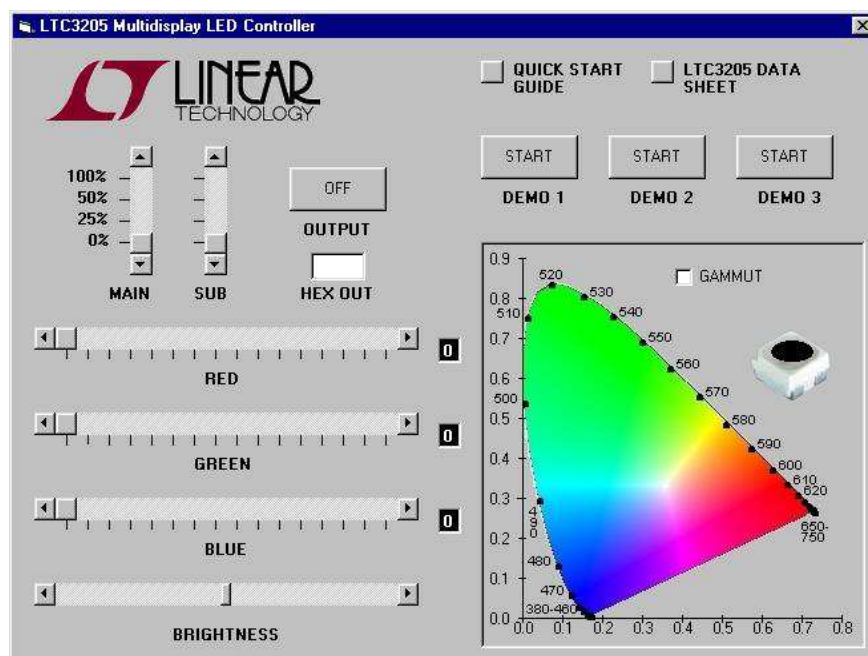
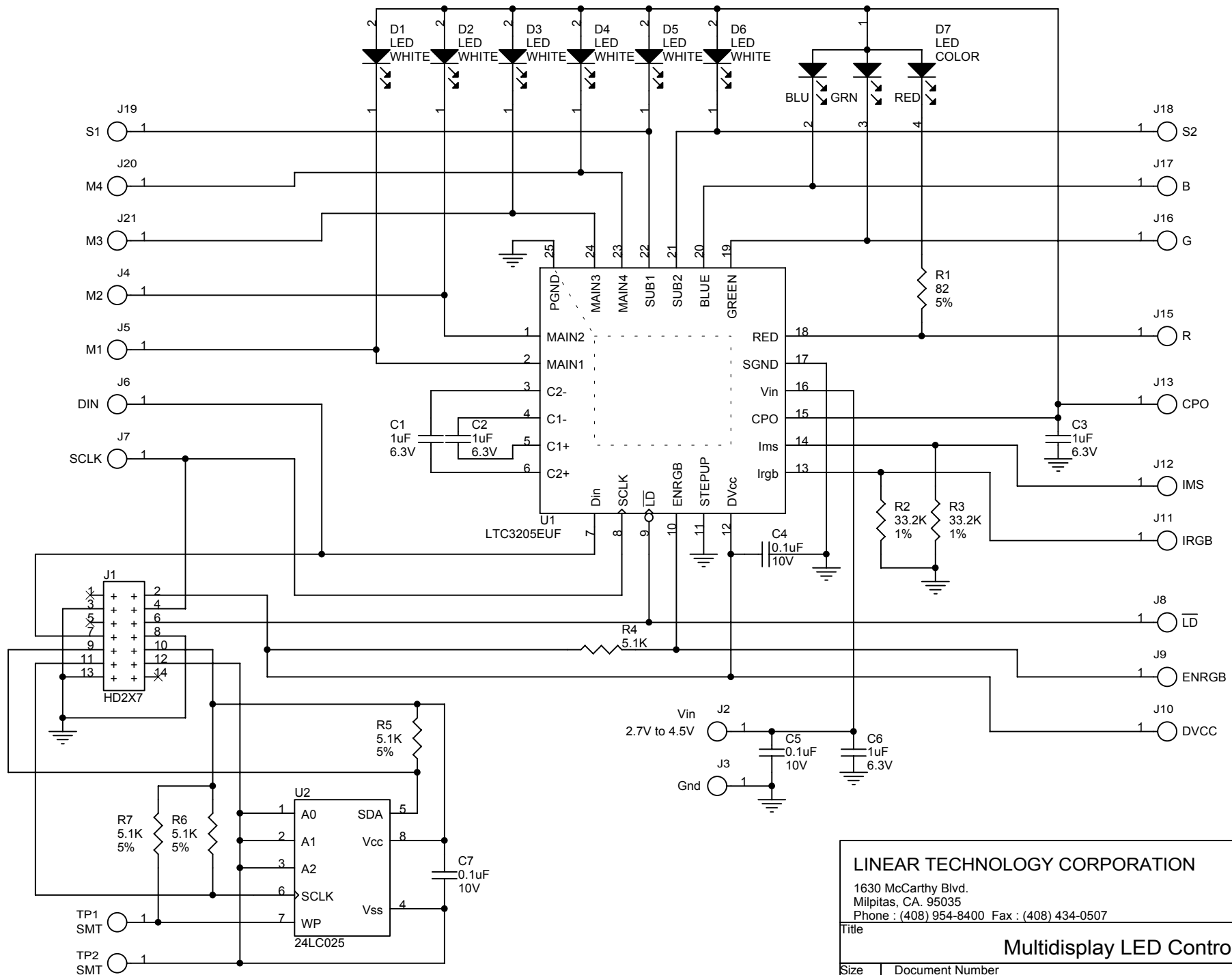

Figure 2. LTC3205 Control Window

NOTES: UNLESS OTHERWISE SPECIFIED



LINEAR TECHNOLOGY CORPORATION
 1630 McCarthy Blvd.
 Milpitas, CA. 95035
 Phone : (408) 954-8400 Fax : (408) 434-0507

Title: **Multidisplay LED Controller**

Size A	Document Number DC629A	LTC3205EUF	Rev
-----------	---------------------------	------------	-----

Date: Thursday, February 06, 2003 Sheet 1 of 1

NOTES: UNLESS OTHERWISE SPECIFIED

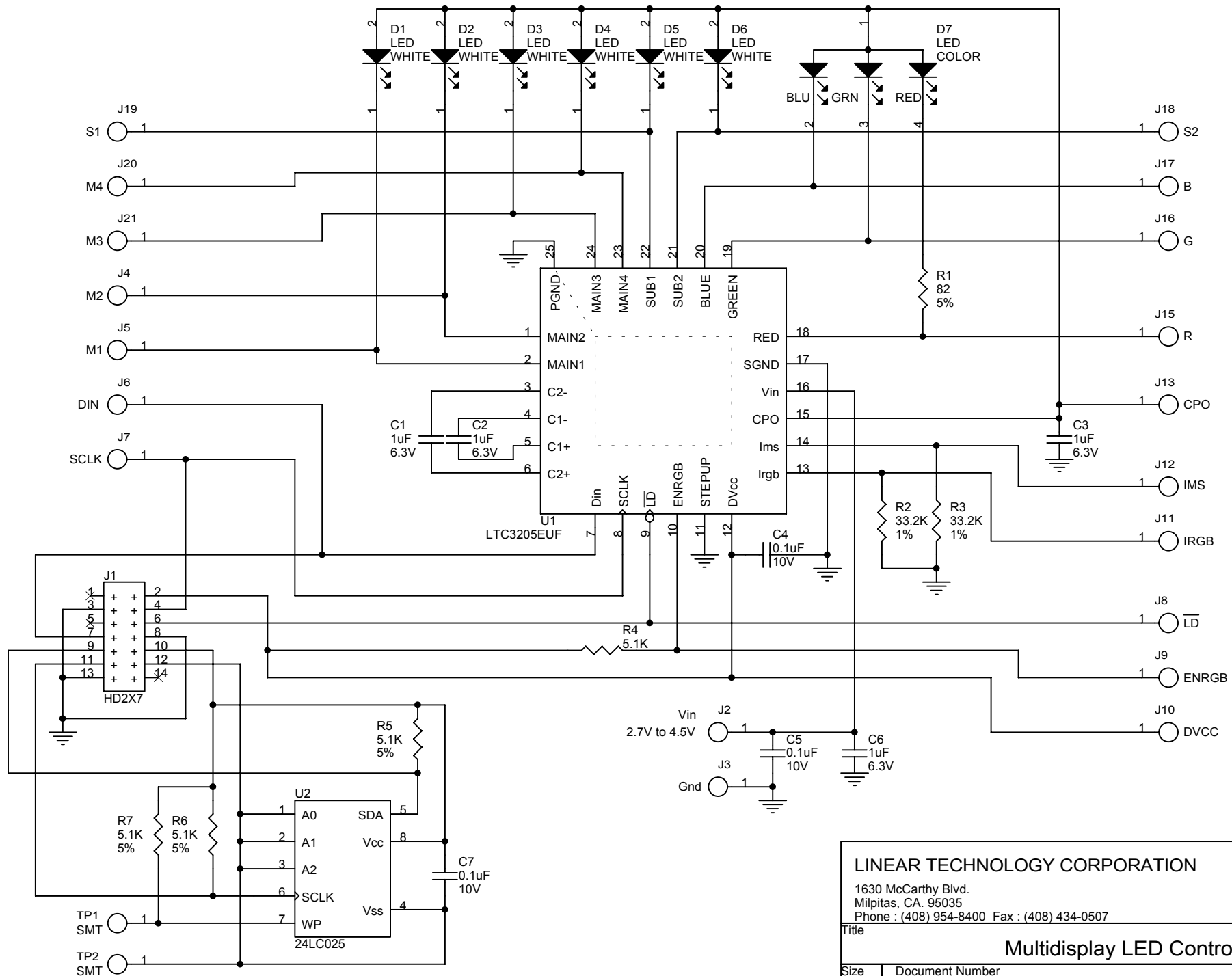

LINEAR TECHNOLOGY CORPORATION
 1630 McCarthy Blvd.
 Milpitas, CA. 95035
 Phone : (408) 954-8400 Fax : (408) 434-0507

Title
Multidisplay LED Controller

Size A	Document Number DC629A	LTC3205EUF	Rev
Date: Thursday, February 06, 2003	Sheet 1 of 1		

Item	Qty	Reference	Part Description	Manufacture / Part #
1	3	C4,C5,C7	CAP., CHIP X5R 0.1uF 10V	AVX, 0402ZD104K 0402
2	4	C1,C2,C3,C6	CAP., CHIP X5R 1uF 6.3V	TAIYO YUDEN, JMK107BJ105MA 0603
3	2	J2,J3	TURRET TESTPOINT .064"	MILL-MAX, 2308-02
4	6	D1-D6	LED, SMT WHITE	NICHIA, NSCW100
5	1	D7	LED, SMT COLOR RGB	NICHIA, NSCM315C
6	1	J1	SOCKET, 2X7 2MM STRAIGHT	MOLEX/WALDOM 87331-1420
7	1	R1	RES., CHIP 82 Ohm 5%	AAC CR05-820JM 0402
8	4	R4,R5,R6,R7	RES., CHIP 5.1K 5%	AAC CR05-512JM 0402
9	2	R2,R3	RES., CHIP 32.4K 1%	PANASONIC ERJ-2RKF3242X 0402
10	1	U2	IC., SERIAL EEPROM	MICROCHIP 24LC025 TSSOP8
11	1	U1	IC., MULTIDISPLAY LED CONTROLLER	LINEAR TECHNOLOGY, LTC3205EUF
12	0	TP1,TP2	OPT.	OPT.