



Chipsmall Limited consists of a professional team with an average of over 10 year of expertise in the distribution of electronic components. Based in Hongkong, we have already established firm and mutual-benefit business relationships with customers from,Europe,America and south Asia,supplying obsolete and hard-to-find components to meet their specific needs.

With the principle of “Quality Parts,Customers Priority,Honest Operation,and Considerate Service”,our business mainly focus on the distribution of electronic components. Line cards we deal with include Microchip,ALPS,ROHM,Xilinx,Pulse,ON,Everlight and Freescale. Main products comprise IC,Modules,Potentiometer,IC Socket,Relay,Connector.Our parts cover such applications as commercial,industrial, and automotives areas.

We are looking forward to setting up business relationship with you and hope to provide you with the best service and solution. Let us make a better world for our industry!



## Contact us

Tel: +86-755-8981 8866 Fax: +86-755-8427 6832

Email & Skype: info@chipsmall.com Web: www.chipsmall.com

Address: A1208, Overseas Decoration Building, #122 Zhenhua RD., Futian, Shenzhen, China





June 17, 2003

## DC656A DEMO BOARD QUICK START GUIDE

### INTRODUCTION

The DC656A demo board is used to evaluate the LTC5532ES6, RF power detector with integrated output buffer and voltage reference. The LTC5532 has provisions for offset and gain adjustments. The LTC5532ES6 converts an RF input signal at pin 6 (RF) to a DC voltage at pin 2 (Vout). The RF input frequency range is 300 MHz to 7000 MHz. Maximum input power is 8 dBm. The output voltage at Vout will start at an initial DC value of typically 120 mV +/- 10 mV. When the RF signal is applied, the output voltage will increase.

The optional R1 termination resistor and C3 output shunt capacitor are not placed on PCB. R2 and R3 are 10 kohm resistors. This reflects the gain setting = 2. E3 is an offset adjustment pin. It should be connected to ground for initial tests and measurements.

The DC656A demo board is easily set up for evaluating the LTC5532ES6 RF power detector performance. Follow the procedures outlined below and connections on the attached diagram for proper operation.

1. Connect the input DC power supply (2.7V to 6V) to E1. Connect the power supply ground to. Connect J1 to the RF signal generator via coaxial cable with an SMA connector. It is common practice to include a 2dB or 3dB pad to minimize reflections back into the signal generator.
2. Connect E3 (offset adjustment pin) to ground.
3. Apply an RF input signal and measure the Vout DC voltage at E2.

Optional measurements can be done by changing the R2 resistor from 10 kohm to higher value to increase the gain of the part, if desired.

Additionally the offset voltage can be set to any voltage above 120 mV and the output (Vout) will track.

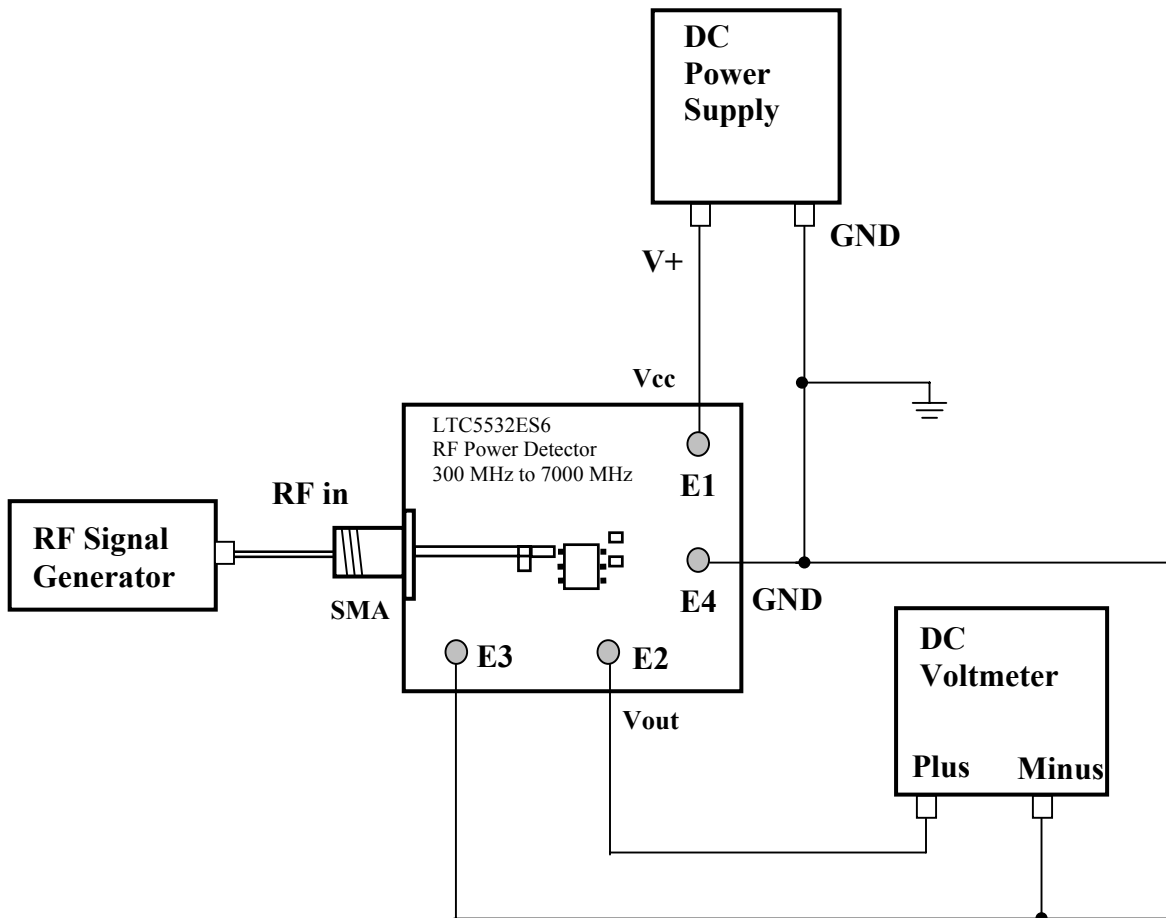

**DC656A Demo Board Connection Diagram**