



Chipsmall Limited consists of a professional team with an average of over 10 year of expertise in the distribution of electronic components. Based in Hongkong, we have already established firm and mutual-benefit business relationships with customers from,Europe,America and south Asia,supplying obsolete and hard-to-find components to meet their specific needs.

With the principle of "Quality Parts,Customers Priority,Honest Operation,and Considerate Service",our business mainly focus on the distribution of electronic components. Line cards we deal with include Microchip,ALPS,ROHM,Xilinx,Pulse,ON,Everlight and Freescale. Main products comprise IC,Modules,Potentiometer,IC Socket,Relay,Connector.Our parts cover such applications as commercial,industrial, and automotives areas.

We are looking forward to setting up business relationship with you and hope to provide you with the best service and solution. Let us make a better world for our industry!



Contact us

Tel: +86-755-8981 8866 Fax: +86-755-8427 6832

Email & Skype: info@chipsmall.com Web: www.chipsmall.com

Address: A1208, Overseas Decoration Building, #122 Zhenhua RD., Futian, Shenzhen, China



DESCRIPTION

Demonstration circuit DC674B is a complete Fast Battery Charger capable of charging 3, 4, 8 or 10 series connected NiMH or NiCd cells. Other cell counts can also be charged (up to 16 cells) by installing an appropriate resistor on the board.

The power portion of the circuit consists of a 550kHz synchronous step-down constant current source which provides 2A of charge current. Other charge currents can be selected by changing the sense resistor value, and for higher charge current (2 to 4A), the PC board has a dual layout for the top switch to allow a larger FET to be used. A PowerPath™ FET is also included that provides a low voltage drop path between the battery

and an external system load when the input power is removed

Charge termination includes $-\Delta V$, $\Delta T/\Delta t$, peak voltage and a safety timer. The thermistor function is set by the NTC jumper, JP1. Battery chemistry is set by the CHEM jumper, JP2. The number of series cells is set by the CELLS jumper, J1. Finally, the safety timer length is set by the TIME jumper, J2. Four LEDs indicate charger ready, top-off charge, charging, and FAULT status.

Design files for this circuit board are available. Call the LTC factory.

LT, LT, LTC, LTM, Linear Technology and the Linear logo are registered trademarks and PowerPath is a trademark of Linear Technology Corporation. All other trademarks are the property of their respective owners.

Performance Summary $T_A = 25^\circ\text{C}$

PARAMETER	CONDITIONS / NOTES	VALUE
Minimum Input Voltage	3 series cells (Default)	6.3V
	4 series cells	8.3V
	6 series cells	12.3V
	10 series cells	20.3V
	n series cells	$n \cdot 2.0V + 0.3V$
Maximum Input Voltage	Limited by Input Capacitor Volt Ratings.	25V
Maximum Charge Current		2A \pm 8%
$-\Delta V$ Termination	CHEM=NiCd	$-20\text{mV} \pm 2\text{mV}$
	CHEM=NiMH	$-10\text{mV} \pm 1.5\text{mV}$
$\Delta T/\Delta t$ Termination	CHEM=NiCd	$2^\circ\text{C}/\text{min} \pm 0.16^\circ\text{C}$ Temperature Rise
	CHEM=NiMH	$1^\circ\text{C}/\text{min} \pm 0.14^\circ\text{C}$ Temperature Rise
Precharge Current	$350\text{mV} < V_{\text{CELL}} < 900\text{mV}$	400mA \pm 80mA
Top Off Charge Current	CHEM=NiMH, $\Delta T/\Delta t$ Termination Only	200mA \pm 50mA

QUICK START PROCEDURE

Demonstration circuit 674B is easy to set up to evaluate the performance of the LTC4011. Refer to Figure 1 for proper measurement equipment setup and follow the procedure below.

1. Set the jumpers according to the type and specifications of the pack under evaluation.
 2. With all power off, connect input power supply, and meters as shown in Figure 1.
 3. Preset the system load to 0A and the input supply to 0V, 0A current limit.
 4. Turn on the supplies, setting the current limit to 2A.
 5. Adjust the input voltage to the desired value, up to 25V.
 6. Connect the battery to begin charging.
- Optional**
1. To use a battery with a 5-pin blade connector, use J3.
 2. To use a system load up to 1A in parallel with the charging circuit, connect to SYSTEM LOAD. Adjust load and input supply current limit as necessary.
 3. For external thermistor connection, set jumper JP1 to BAT. For the on-board thermistor, set JP1 to BRD. To remove the thermistor from the circuit, set JP1 to OUT.
 4. For custom cell count, set jumper J1 to XCELLS and install R14 with the appropriate value.
 5. For alternative timer settings, set jumper J2 as necessary. For custom timer settings, set J2 to 4.3Hr and install R23 with the appropriate value.
Note: This value also affects Precharge and TOC times as well.
 6. To measure the average voltage per cell, connect a meter to VCELL.
 7. To pause the charge cycle, connect a lead from PAUSE to GND.
Note: This pauses the timer as well, but status outputs remain active.

Please refer to the LTC4011 datasheet for additional information.

QUICK START GUIDE FOR DEMONSTRATION CIRCUIT DC 674B
 STANDALONE NiMH/NiCd BATTERY CHARGER BOARD

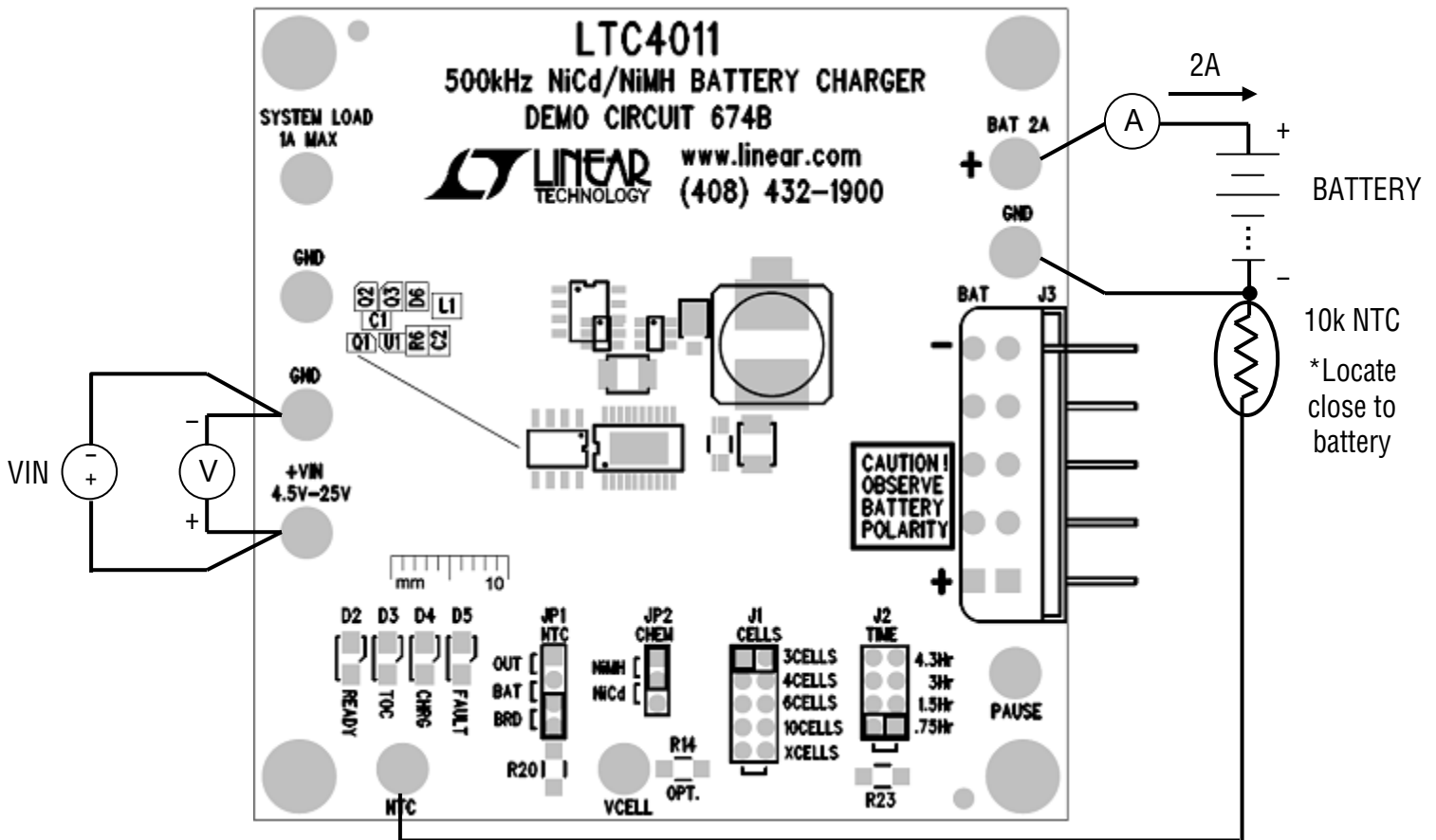

Figure 1. Proper Measurement Equipment Setup

CHARGING NiMH/NiCd BATTERIES

Nickel based batteries are typically charged by a constant current source, allowing the battery voltage to rise to the level it requires (within limits) to force this current. When batteries are fast charged (1 to 2 hours) the charge cycle must be terminated when the battery reaches full charge. Detecting when the battery is fully charged is usually done by one or more methods.

1. $-\Delta V$ method: Measures the battery voltage as it is being charged with a constant current. The voltage will rise as the battery accepts charge. When it approaches full charge, the battery voltage will begin rising faster, reach a peak then begin to drop. When the battery voltage drops a fixed amount of mV (depending on battery chemistry), the battery is fully charged and the charge cycle terminates.

2. $\Delta T/\Delta t$ method: Measures the rate of temperature rise vs. time. During a fast charge, the battery temperature begins to rise. When it approaches full charge, the battery temperature

will begin to rise quickly. When the rate of temperature rise reaches a fixed number of $^{\circ}\text{C}/\text{minute}$ (depending on battery chemistry) the charge cycle terminates. NiMH batteries add a top-off charge that continues charging at a lower current until the timer ends the charge cycle.

For either of these termination methods to work correctly, the charge current must be programmed to a sufficiently high current level. LTC recommends between C/2 and 2C rates, but charging at 2C may result in excessive cell temperature, especially for small, low capacity NiMH cells. Rates lower than C/2 will be too difficult to detect for LTC4011 termination algorithm.

“C rate” is a measure of cell capacity in mAh. For example, to charge an 1800mAh battery at 1C would require a charge current of 1.8A.

DIFFERENCES BETWEEN NiCd & NiMH BATTERIES

NiCd batteries exhibit very little temperature rise during most of the charge cycle. The temperature rise mainly occurs near the end of the charge cycle.

Whereas, NiMH battery temperature rise occurs throughout the charge cycle and accelerates near the end of the charge cycle.

The $-\Delta V$ that occurs when charging a NiMH battery is less than a NiCd. This makes $-\Delta V$ termination somewhat more difficult to detect for a NiMH battery, therefore it is also recommended to include a thermistor in the NiMH battery packs.

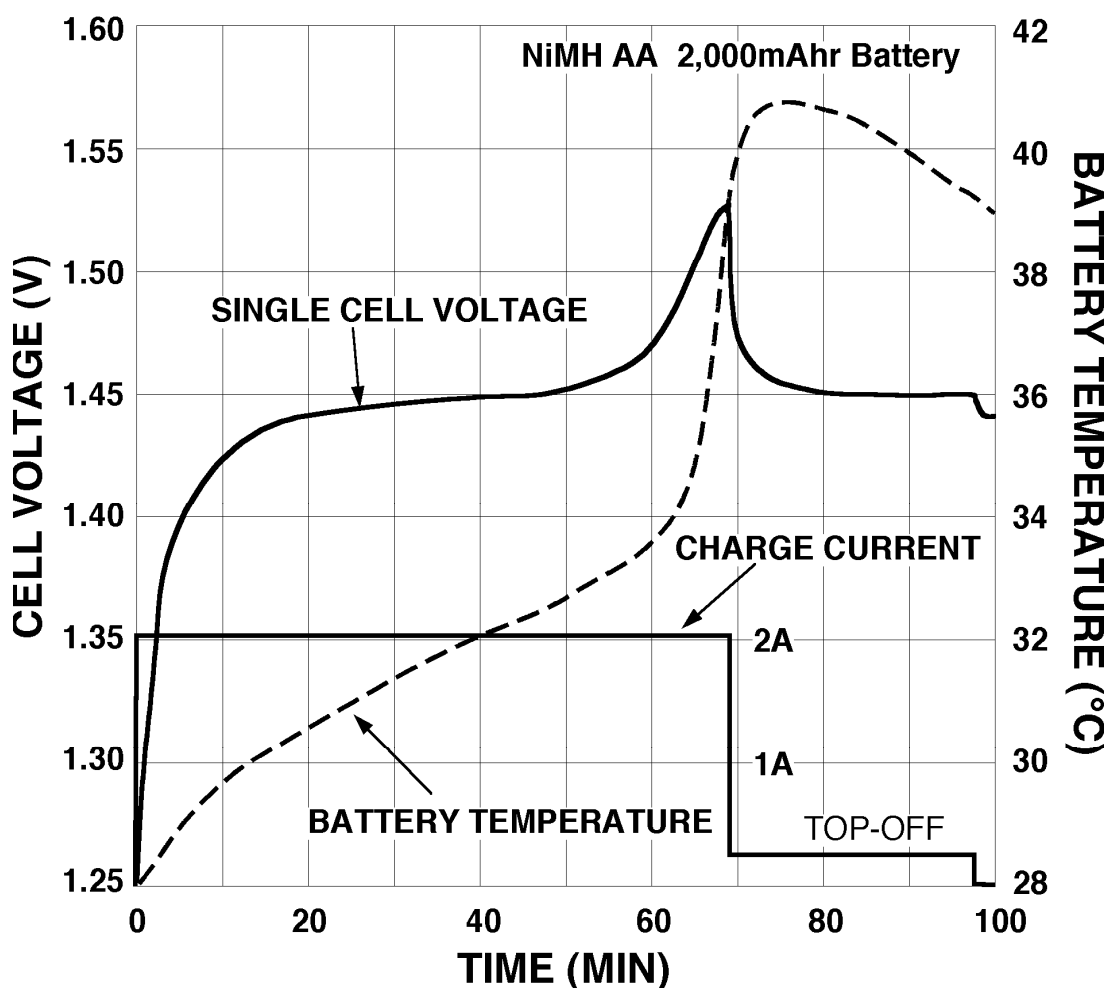

Figure 2. NiMH Charge Profile (1C Charge Rate)

QUICK START GUIDE FOR DEMONSTRATION CIRCUIT DC 674B
STANDALONE NiMH/NiCd BATTERY CHARGER BOARD

PARTS LIST

ITEM	QTY	REFERENCE	PART DESCRIPTION	MANUFACTURE / PART #
Required Circuit Components				
1	2	C1, C2	Capacitor, X5R, 10 μ F, 20% 25V 1210	Taiyo Yuden, TMK325BJ106MM
2	3	C3, C4, C5	Capacitor, X5R, 0.1 μ F, 25V 0603	AVX, 06033D104KAT2A
3	1	D6	Diode Schottky, 1A, 40V POWERMITE	Micro Semi., UPS140
4	1	L1	Inductor, 10 μ H	Toko, 919AS-100M
5	1	Q1	MOSFET, Dual P-Channel SuperSOT-8	Fairchild, FDS6975P
6	1	Q2	MOSFET, Single P-Channel SuperSOT-6	Fairchild, FDC658AP
7	1	Q3	MOSFET, N-Channel, 30V	Vishay, SI3434DV
8	1	R6	Resistor, 0.05 Ω , 1/2W, 1% 1206	Panasonic, ERJ-L08KJ50MV
9	1	R7	Resistor, 9.76k, 1/16W, 1% 0402	Vishay, CRCW04029K76FKED
10	1	R8	Resistor, 20k, 1/16W, 5% 0402	Vishay, CRCW040220K0JNED
11	2	R9, R18	Resistor, 10.0k, 1/16W, 1% 0402	Vishay, CRCW040210K0FKED
12	1	R10	Resistor, 20.0k, 1/16W 1% 0402	Vishay, CRCW040220K0FKED
13	1	R15	Resistor, 24.9k, 1/16W 1% 0402	Vishay, CRCW040224K9FKED
14	1	R21	Resistor, 28.0k, 1/16W 1% 0402	Vishay, CRCW040228K0FKED
15	1	U1	I.C. Battery Charger TSSOP-20	Linear Technology LTC4011EFE#PBF
Additional Demo Board Circuit Components				
1	0	C6, C7	OPT.	
2	1	D1	Diode, Zener, 18V SOD-323	Diode Inc., MMSZ5248BS-7
3	1	D2	LED, Green	Rohm, SML-010FTT86L
4	2	D3, D4	LED, Orange	Rohm, SML-010DTT86L
5	1	D5	LED, Red	Rohm, SML-010VTT86L
6	1	R1	Resistor, 47K, 1/16W, 5% 0402	Vishay, CRCW040247K0JNED
7	4	R2-R5	Resistor, 3K, 1/16W, 5% 0402	Vishay, CRCW04023K00JNED
8	1	R11	Resistor, 30.1K, 1/16W, 1% 0402	Vishay, CRCW040230K1FKED
9	2	R12, R16	Resistor, 49.9K, 1/16W, 1% 0402	Vishay, CRCW040249K9FKED
10	1	R13	Resistor, 90.9K, 1/16W, 1% 0402	Vishay, CRCW040290K9FKED
11	0	R14, R23	OPT.	
12	1	R17	Resistor, 100K, 1/16W, 1% 0402	Vishay, CRCW0402100KFKED
13	1	R19	Resistor, 28.0K, 1/16W, 1% 0402	Vishay, CRCW040228K0FKED
14	1	R20	Resistor, 10K, 1/4W, 5% 1206	Vishay, CRCW120610K0JNEA
15	1	R22	Resistor, 0 Ω , 1/16W, 0402	Vishay, CRCW04020000Z0ED
Hardware/Components (For Demo Board Only)				
1	1	JP1	Jumper, 0.079"CC, 4 Pin	Sullins, NRPNO41PAEN
2	1	JP2	Jumper, 0.079"CC, 3 Pin	Sullins, NRPNO31PAEN
3	1	J1	Header, 10 Pin, 2 Row, .079CC	Samtech, TMM-105-02-L-D
4	1	J2	Header, 8 Pin, 2 Row, .079CC	Sullins, NRPNO42PAEN
5	1	J3	Header, Right Angle	TE Connectivity, 5787441-1
6	4	JP1, JP2, J1, J2	Shunt	Samtec, 2SN-BK-G
7	9	E1-E9	Turret, Test Pin, .095"	Mill-Max 2501-2-00-80-00-00-07-0
8	4		Hardware Screw, #4-40, 1/4"	Any
9	4		Standoff, #4-40, 1/4"	Micro Plastics 14HTSP101

QUICK START GUIDE FOR DEMONSTRATION CIRCUIT DC674B STANDALONE NiMH/NiCd BATTERY CHARGER BOARD

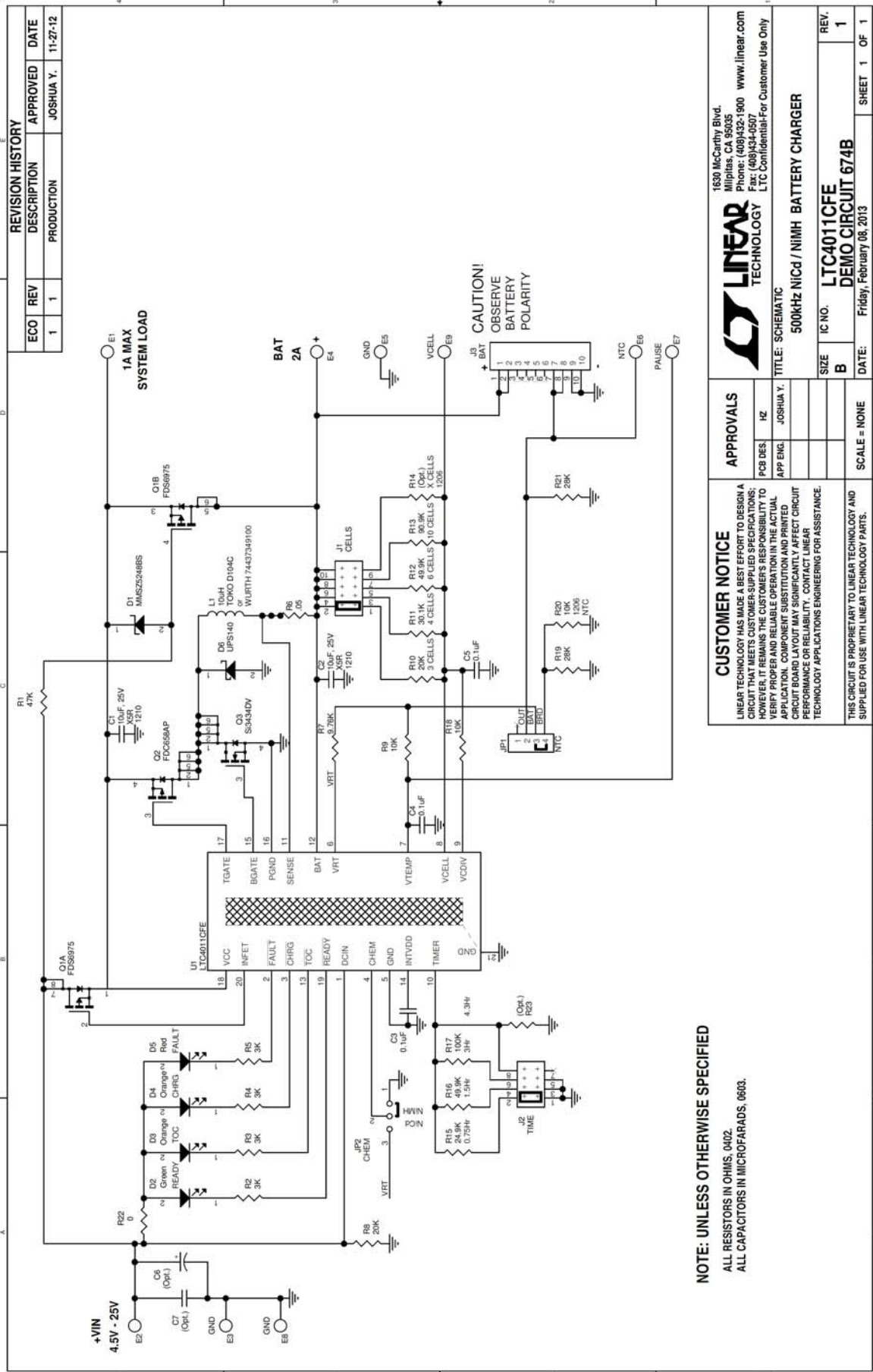

NOTE: UNLESS OTHERWISE SPECIFIED
ALL RESISTORS IN OHMS, 0402.
ALL CAPACITORS IN MICROFARADS, 0603.

REVISION HISTORY

ECO	REV	DESCRIPTION	APPROVED	DATE
1	1	PRODUCTION	JOSHUA Y.	11-27-12

LINEAR TECHNOLOGY
1630 McCarthy Blvd.
Milpitas, CA 95035
Phone: (408)432-1900 www.linear.com
Fax: (408)434-0507
LTC Confidential-For Customer Use Only

APPROVALS

PCB DES:	HZ
APP ENG:	JOSHUA Y.

500kHz NiCd / NiMH BATTERY CHARGER

SIZE: B
IC NO: **LTC4011CFE**
DEMO CIRCUIT 674B

DATE: Friday, February 08, 2013

SHEET 1 OF 1

CUSTOMER NOTICE
LINEAR TECHNOLOGY HAS MADE A BEST EFFORT TO DESIGN A CIRCUIT THAT MEETS CUSTOMER-SUPPLIED SPECIFICATIONS; HOWEVER, IT REMAINS THE CUSTOMER'S RESPONSIBILITY TO VERIFY PROPER AND RELIABLE OPERATION IN THE ACTUAL APPLICATION. COMPONENT SUBSTITUTION AND PRINTED CIRCUIT BOARD LAYOUT MAY SIGNIFICANTLY AFFECT CIRCUIT PERFORMANCE OR RELIABILITY. CONTACT LINEAR TECHNOLOGY APPLICATIONS ENGINEERING FOR ASSISTANCE.

THIS CIRCUIT IS PROPRIETARY TO LINEAR TECHNOLOGY AND SUPPLIED FOR USE WITH LINEAR TECHNOLOGY PARTS.