



Chipsmall Limited consists of a professional team with an average of over 10 year of expertise in the distribution of electronic components. Based in Hongkong, we have already established firm and mutual-benefit business relationships with customers from,Europe,America and south Asia,supplying obsolete and hard-to-find components to meet their specific needs.

With the principle of “Quality Parts,Customers Priority,Honest Operation,and Considerate Service”,our business mainly focus on the distribution of electronic components. Line cards we deal with include Microchip,ALPS,ROHM,Xilinx,Pulse,ON,Everlight and Freescale. Main products comprise IC,Modules,Potentiometer,IC Socket,Relay,Connector.Our parts cover such applications as commercial,industrial, and automotives areas.

We are looking forward to setting up business relationship with you and hope to provide you with the best service and solution. Let us make a better world for our industry!



Contact us

Tel: +86-755-8981 8866 Fax: +86-755-8427 6832

Email & Skype: info@chipsmall.com Web: www.chipsmall.com

Address: A1208, Overseas Decoration Building, #122 Zhenhua RD., Futian, Shenzhen, China





DC795A DEMO BOARD QUICK START GUIDE

Description:

The DC795A demo circuit board is intended to demonstrate the capabilities of the LT5527 high-signal-level downconverting mixer IC for cable and wireless infrastructure applications.

The LT5527 (Figure 1) is a broadband high signal level active mixer optimized for high linearity downconverter receiver/transmitter applications for cable and wireless infrastructure. The IC includes a high-speed differential LO buffer amplifier driving a double-balanced mixer. The LO buffer is internally 50ohm-matched for wideband, single-ended operation with no external components.

The LT5527 IC's RF input port incorporates an integrated transformer and is internally matched to 50ohms over the 1.7GHz to 2.7GHz frequency range. The RF input match can be shifted down to 400MHz, or up to 3.7GHz, with a single shunt capacitor or inductor, respectively. The high level of integration minimizes the total solution cost, board space and system-level variation.

The LT5527 delivers high performance and small size without excessive power consumption.

The DC795A demo board allows evaluation of the LT5527 downconverting mixer IC for various receiver and transmitter applications. Its RF input is optimized for 1.7GHz to 2.7GHz frequency range. The IF output frequency range is centered at 240MHz. The LO is internally matched for range of frequencies from 1200MHz to 4000MHz.

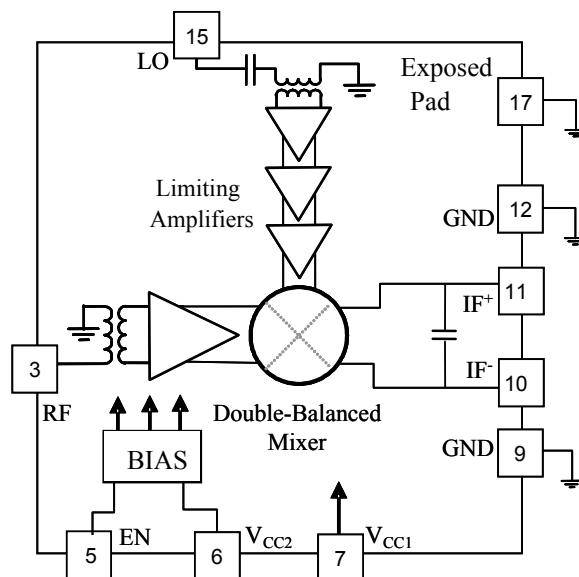

Figure 1. LT5527 IC Block Diagram

LT5527 Downconverting Mixer Single-Tone Measurements.

1. Connect all test equipment as shown in Figure 2.
2. Set the Power Supply voltage to 5V, and set the current limit to 100mA.
3. Connect TP1 (EN) to the 5V power supply; the mixer is enabled (on).
4. Set the Signal Generator #2 to provide a 1900MHz, -10 dBm CW signal to the demo board RF in port.
5. Set the Signal Generator #1 to provide a -3dBm CW signal, at the desired LO frequency (HIGH side LO=2140MHz, or LOW side LO=1660MHz) to the demo board LO in port
6. Set the Spectrum Analyzer center frequency to the IF output frequency (240MHz). Perform mixer conversion gain, and 1dB compression measurements. (e.g., 500MHz). Perform mixer conversion gain, and 1dB compression measurements.
7. Set the Spectrum Analyzer center frequency to the LO frequency. Perform mixer LO to IF leakage measurement.

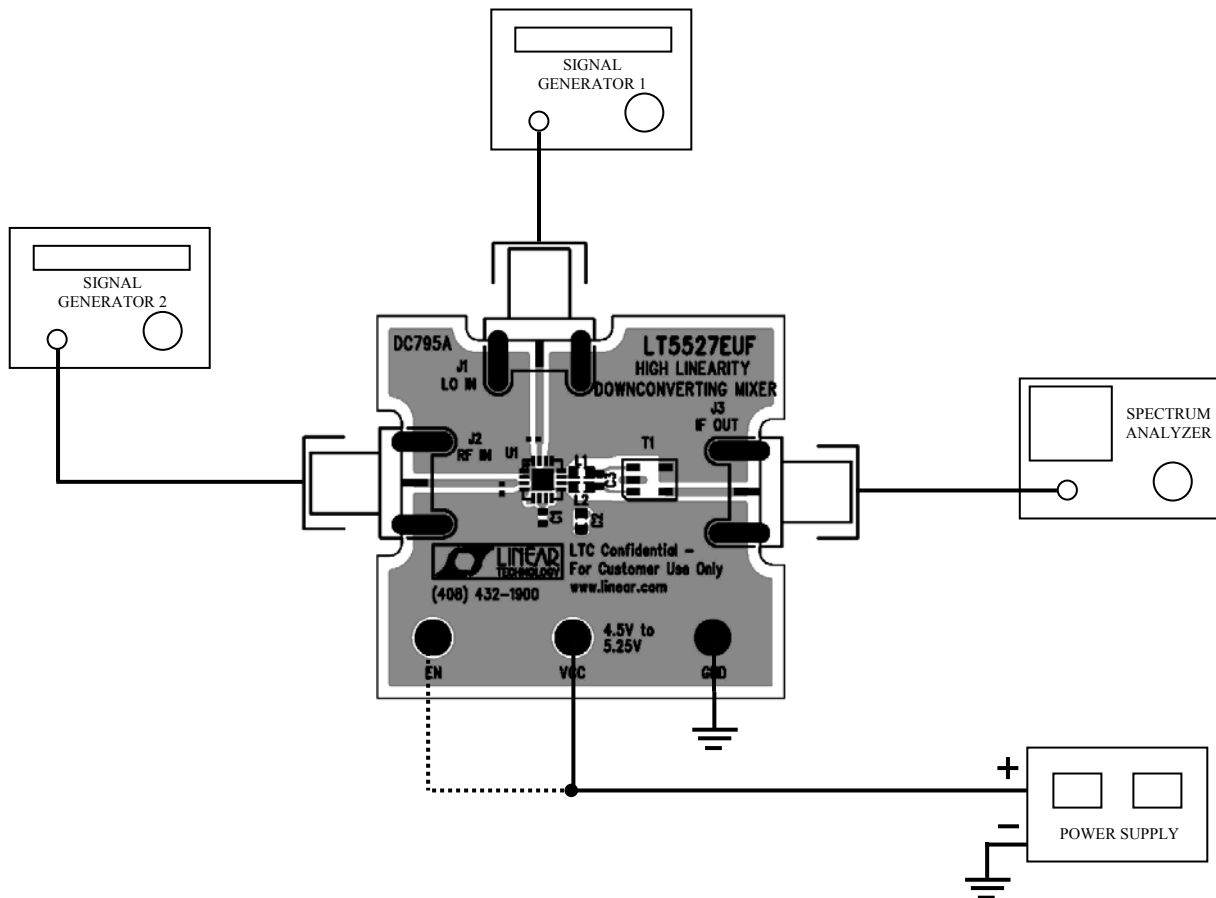

Figure 2. Test Set-Up for Mixer Single-Tone Measurements.

LT5527 Downconverting Mixer Two-Tone Measurements.

1. Connect all test equipment as shown in Figure 3.
 - 1). Use high quality signal generators with low harmonic output for this measurement. Otherwise, low-pass filters should be used to suppress harmonics.
 - 2). A high quality combiner that provides 50ohm termination on all ports and has good port-to port isolation should be used.
 - 3). The two 3dB attenuators on the inputs of the combiner are used to further improve source isolation.
2. Set the Power Supply voltage to 5V, and set the current limit to 100mA.
3. Connect TP1 (EN) to the 5V power supply. Mixer is enabled (on).
4. Set the Signal Generator #1 to provide a -5dBm CW signal, at the desired LO frequency (HIGH side LO=2140MHz, or LOW side LO=1660MHz) to the demo board LOin port.
5. Set the Signal Generator #2 and #3 to provide two -5dBm CW signals to the demo board RFin port—one at 1900MHz, and the other at 11901MHz.
6. Set the Spectrum Analyzer center frequency to the IF output frequency at 240MHz. Perform input 3rd order distortion measurement (i.e. $IIP3 = P_1 + (P_1 - P_3) / 2 - G_c$, where P_1 is the lowest power level of the two desired output tones at either 240MHz or 241MHz, P_3 is the largest 3rd order product at either 239MHz or 242MHz, and G_c is conversion gain. P_1 and P_3 are in units of dBm, and G_c is in dB).

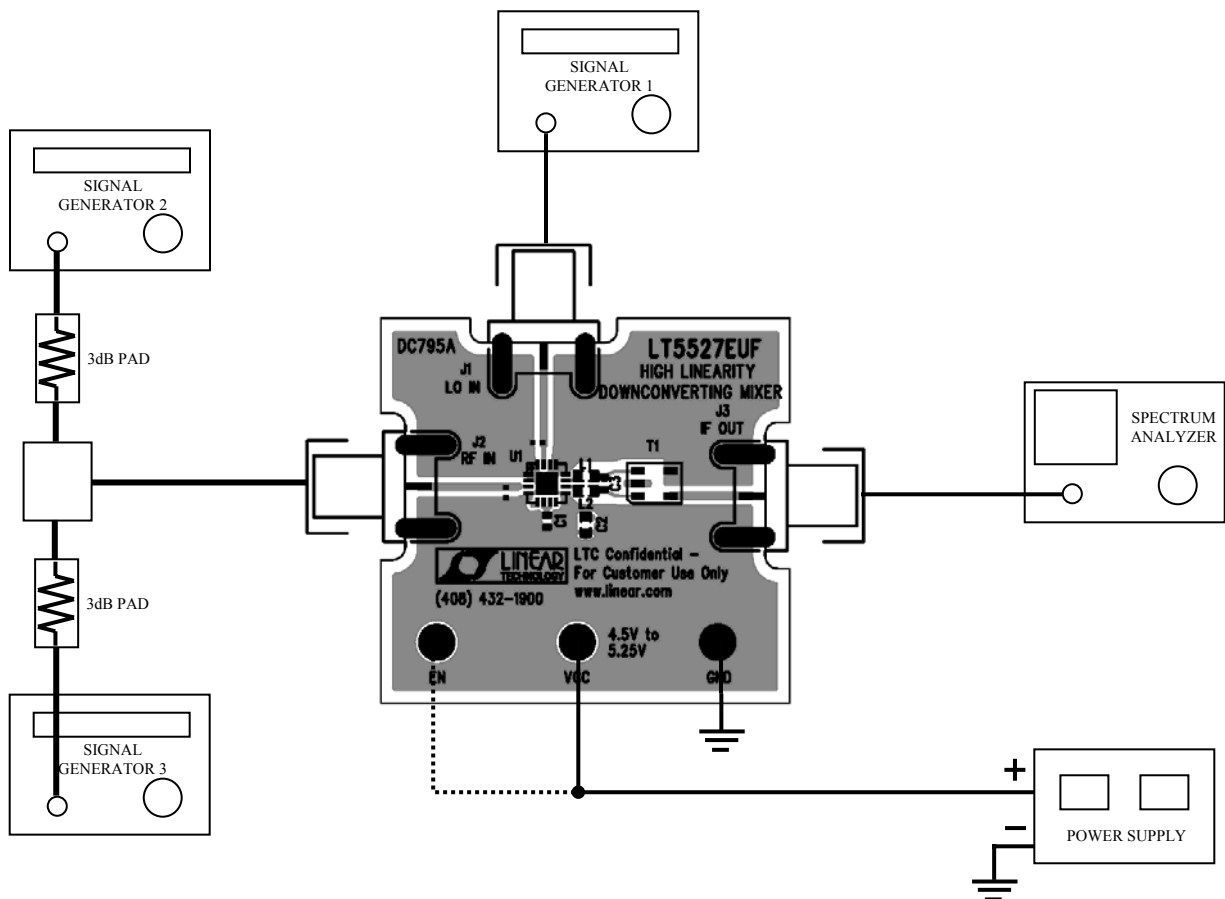
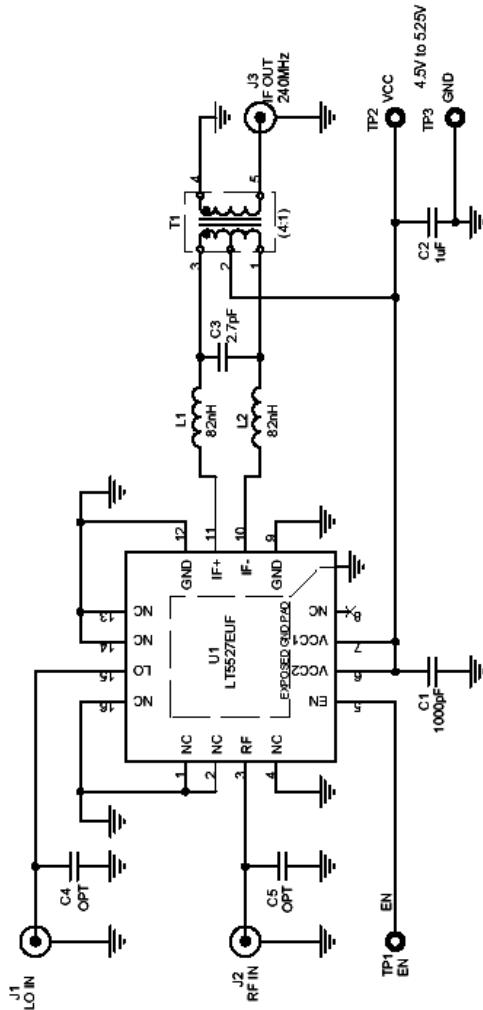

Figure 3. Test Set-Up for Mixer Two-Tone Measurements.

PROPRIETARY DATA:

This circuit is proprietary to Linear Technology and supplied for use with Linear Technology parts.
 CUSTOMER NOTICE: Linear Technology has made a best effort to design a circuit that meets customer-supplied specifications; however, it remains the customer's responsibility to verify proper and reliable operation in the actual application. Component substitution and revised circuit board layout may significantly affect circuit performance or reliability. Contact Linear Technology Applications Engineering for assistance.

REVISION HISTORY				
ECO	REV	DESCRIPTION	DATE	APPROVED



UNLESS OTHERWISE SPECIFIED
 DIMENSIONS ARE IN INCHES
 TOLERANCE ON ANGLE ...
 2 PLACES ... 3 PLACES ...
 ALL DIMENSIONS UNLESS OTHERWISE SPECIFIED
 PER ASME Y14.5M-1994

THIRD ANGLE PROJECTION

DO NOT SCALE DRAWING

CONTRACT NO.	
APPROVALS	DATE
DRAWN JUNE WU	8/2/04
CHECKED	-
APPROVED	-
ENGINEER VLAD D.	8/2/04
DESIGNER	-

		1630 McCarthy Blvd. Milpitas, CA 95035 Phone: (408)432-1900 Fax: (408)434-0507	
TITLE			
LT5527EUF, HIGH LINEARITY DOWNCONVERTING MIXER			
SIZE	CAGE CODE	DWG NO	REV
A		DC795A	A
SCALE NONE	FILENAME LT5527EUF.DSN	SHEET 1	OF 1