



Chipsmall Limited consists of a professional team with an average of over 10 year of expertise in the distribution of electronic components. Based in Hongkong, we have already established firm and mutual-benefit business relationships with customers from,Europe,America and south Asia,supplying obsolete and hard-to-find components to meet their specific needs.

With the principle of “Quality Parts,Customers Priority,Honest Operation,and Considerate Service”,our business mainly focus on the distribution of electronic components. Line cards we deal with include Microchip,ALPS,ROHM,Xilinx,Pulse,ON,Everlight and Freescale. Main products comprise IC,Modules,Potentiometer,IC Socket,Relay,Connector.Our parts cover such applications as commercial,industrial, and automotives areas.

We are looking forward to setting up business relationship with you and hope to provide you with the best service and solution. Let us make a better world for our industry!



Contact us

Tel: +86-755-8981 8866 Fax: +86-755-8427 6832

Email & Skype: info@chipsmall.com Web: www.chipsmall.com

Address: A1208, Overseas Decoration Building, #122 Zhenhua RD., Futian, Shenzhen, China



QUICK START GUIDE FOR DEMONSTRATION CIRCUIT 841 CONSTANT CURRENT BOOST CONVERTER WITH INPUT CURRENT AND OUTPUT VOLTAGE PROTECTION

LT3477

DESCRIPTION

Demonstration circuit 841 is a constant LED current boost converter with input current and output voltage protection featuring the LT[®]3477. The board is optimized to drive 330mA LED arrays with a total LED voltage between the maximum input voltage and 36V. The high input voltage range, high-efficiency low-side internal 3A NPN power switch, two floating current sense amplifiers and overvoltage/voltage feedback amplifier, shutdown control pin, I_{adj} LED current dimming control, externally programmable switching frequency and soft-start capacitor make the LT3477 an extremely powerful and versatile LED driving IC.

DC841 has overvoltage protection below 36V if the LEDs are open or not properly attached to the terminals on the PCB. The shutdown function is activated by pulling the shutdown terminal to ground, but in shutdown the boost configuration allows the input voltage to be seen on the output and if the attached LED array leaks current at the input voltage, the LEDs may not completely turn off in shutdown although IC switching has ceased. The I_{adj} terminals can be used to dim the LED current. In order to activate the I_{adj} terminals, the resistors shorting the I_{adj} pins to VIN

must be removed and the resistors between the I_{adj} terminals and pins must be stuffed.

A few simple modifications can be made to DC841 in order to convert the board from a boost converter to a buck converter or any type of step-up and step-down converter. Please consult the datasheet for schematic details and the factory for customization details.

The LT3477 datasheet gives a complete description of the part, operation and applications information. The datasheet must be read in conjunction with this Quick Start Guide for demonstration circuit 841. The LT3477 is assembled in a small 20-lead plastic TSSOP FE package with a thermally enhanced ground pad. Proper board layout is essential for maximum thermal performance. See the datasheet section 'Layout Considerations'.

Design files for this circuit board are available. Call the LTC factory.

LT is a trademark of Linear Technology Corporation

QUICK START PROCEDURE

Demonstration circuit 841 is easy to set up to evaluate the performance of the LT3477. Follow the procedure below:

NOTE: Make sure that the input voltage does not exceed 16V.

1. Connect an array of LEDs with forward voltage less than 36V, but greater than the input voltage, to the LED+ and LED- terminals on the PCB as shown.

2. Connect a 2.7V to 16V input power supply to the VIN and GND terminals on the PCB and observe the bright LEDs and the constant LED current.

QUICK START GUIDE FOR DEMONSTRATION CIRCUIT 841 CONSTANT CURRENT BOOST CONVERTER WITH INPUT CURRENT AND OUTPUT VOLTAGE PROTECTION

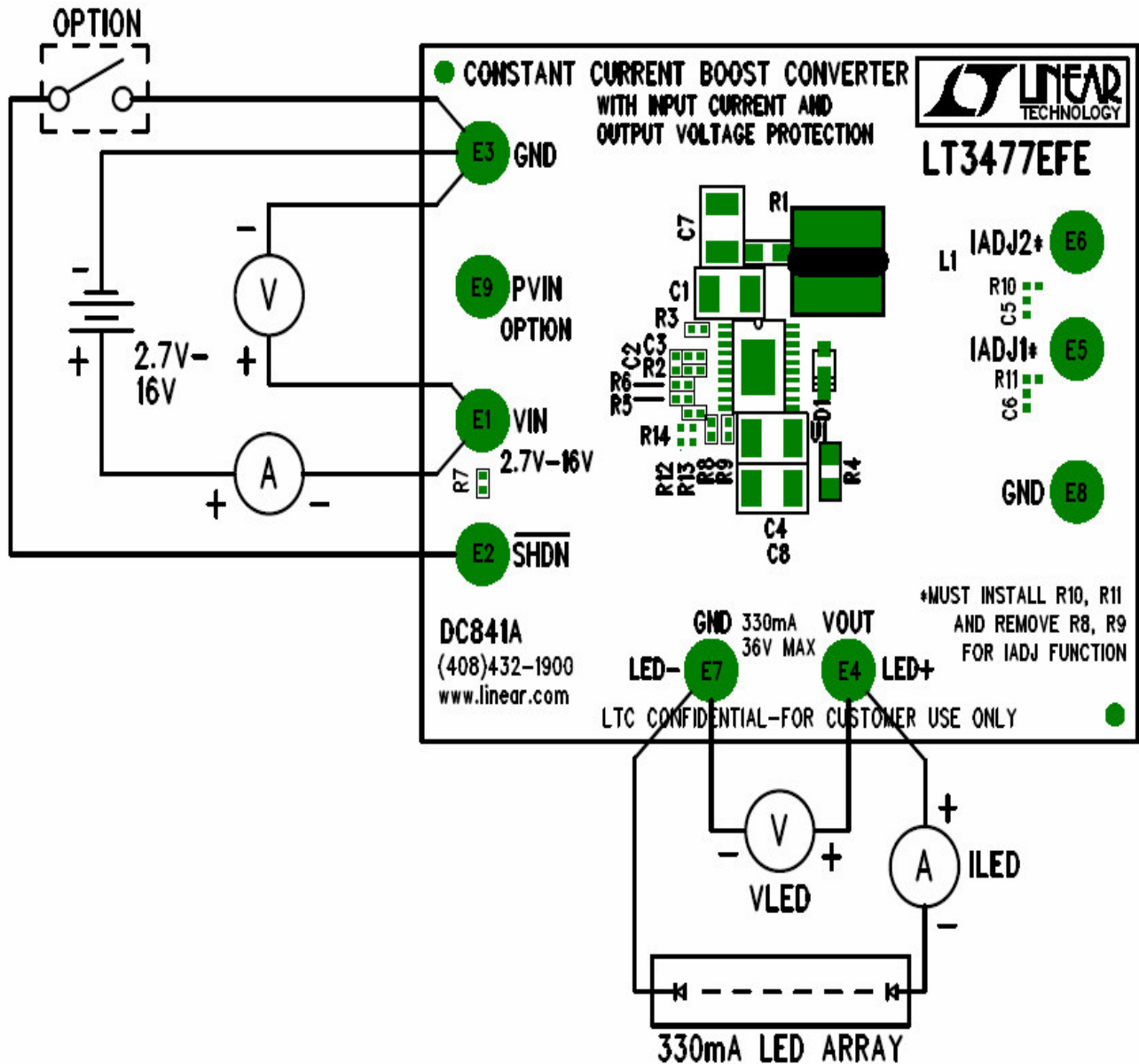

QUICK START GUIDE FOR DEMONSTRATION CIRCUIT 841 CONSTANT CURRENT BOOST CONVERTER WITH INPUT CURRENT AND OUTPUT VOLTAGE PROTECTION

