



Chipsmall Limited consists of a professional team with an average of over 10 year of expertise in the distribution of electronic components. Based in Hongkong, we have already established firm and mutual-benefit business relationships with customers from,Europe,America and south Asia,supplying obsolete and hard-to-find components to meet their specific needs.

With the principle of "Quality Parts,Customers Priority,Honest Operation,and Considerate Service",our business mainly focus on the distribution of electronic components. Line cards we deal with include Microchip,ALPS,ROHM,Xilinx,Pulse,ON,Everlight and Freescale. Main products comprise IC,Modules,Potentiometer,IC Socket,Relay,Connector.Our parts cover such applications as commercial,industrial, and automotives areas.

We are looking forward to setting up business relationship with you and hope to provide you with the best service and solution. Let us make a better world for our industry!



## Contact us

Tel: +86-755-8981 8866 Fax: +86-755-8427 6832

Email & Skype: info@chipsmall.com Web: www.chipsmall.com

Address: A1208, Overseas Decoration Building, #122 Zhenhua RD., Futian, Shenzhen, China



## DESCRIPTION

Demonstration circuit 843 is a high current boost LED driver featuring the LT<sup>®</sup>3479 and the AOT 3218 Flash LED. The board is optimized for 700mA 300ms LED flash current or 150mA constant LED torch current with a single lithium ion battery input voltage range of 2.7V to 4.5V. The lithium ion battery input voltage range, high LED flash current and separate torch mode current setting, internal npn power switch, small inductor solution, minimal external components, and simple design makes the LT3479 an excellent solution for space-constrained camera flash solutions with high battery capability.

Demonstration circuit 843 is turned on and off by pressing the ON/OFF button. A TORCH button turns the LED on at 150mA for cellular telephone or other video recording. The FLASH button flashes the LED at 700mA for 300ms for camera flash operation. The buttons control the state of the PIC microcontroller IC that is programmed with DC843A software. The PIC keeps the LED from being constantly in flash mode, preventing overheating and failure of the LED. The PIC also controls the flash time. When no buttons are pressed for a short time, the PIC turns off and the circuit enters low-power mode for battery-life preservation.

A red/green LED indicates the state of the PIC. The LED is ready to flash or torch if the state indicator is blipping green. If the indicator is not on, the PIC is turned off. For a brief time after the flash has occurred, the state-indicator LED is red, indicating that another flash cannot happen, even if the button is pressed, until the red LED is off and the green LED is blipping again.

The LT3479 datasheet gives a complete description of the part, operation and applications information. The datasheet must be read in conjunction with this Quick Start Guide for demonstration circuit 843. In addition, Advanced Optoelectronic Technology's datasheet featuring AOT 3218 (<http://www.aot.com.tw>) must be read to understand thermal and LED current constraints for varying flash current pulse-widths and intensity. The LT3479 is assembled in a small low profile DFN package. Proper board layout is essential for maximum thermal performance. See the datasheet section 'Layout Considerations'.

**Design files for this circuit board are available. Call the LTC factory.**

LT is a trademark of Linear Technology Corporation

## QUICK START PROCEDURE

Demonstration circuit 843 is easy to set up to evaluate the performance of the LT3479. Follow the procedure below:

1. Connect 2.7-4.5V input voltage as shown in Figure 1 to VIN and GND terminals.
2. If the state-indicator LED is not blipping green, press the ON/OFF button to turn on the circuit.
3. Press 'FLASH' to observe a 300ms, 700mA camera flash on the AOT 3218 LED.
4. Press 'TORCH' to observe constant 150mA LED light for recording video.
5. Press 'TORCH' to turn off the 150mA video mode.
6. Press 'ON/OFF' to turn off the circuit or let the circuit turn off by not pressing any buttons for approximately 10 seconds.

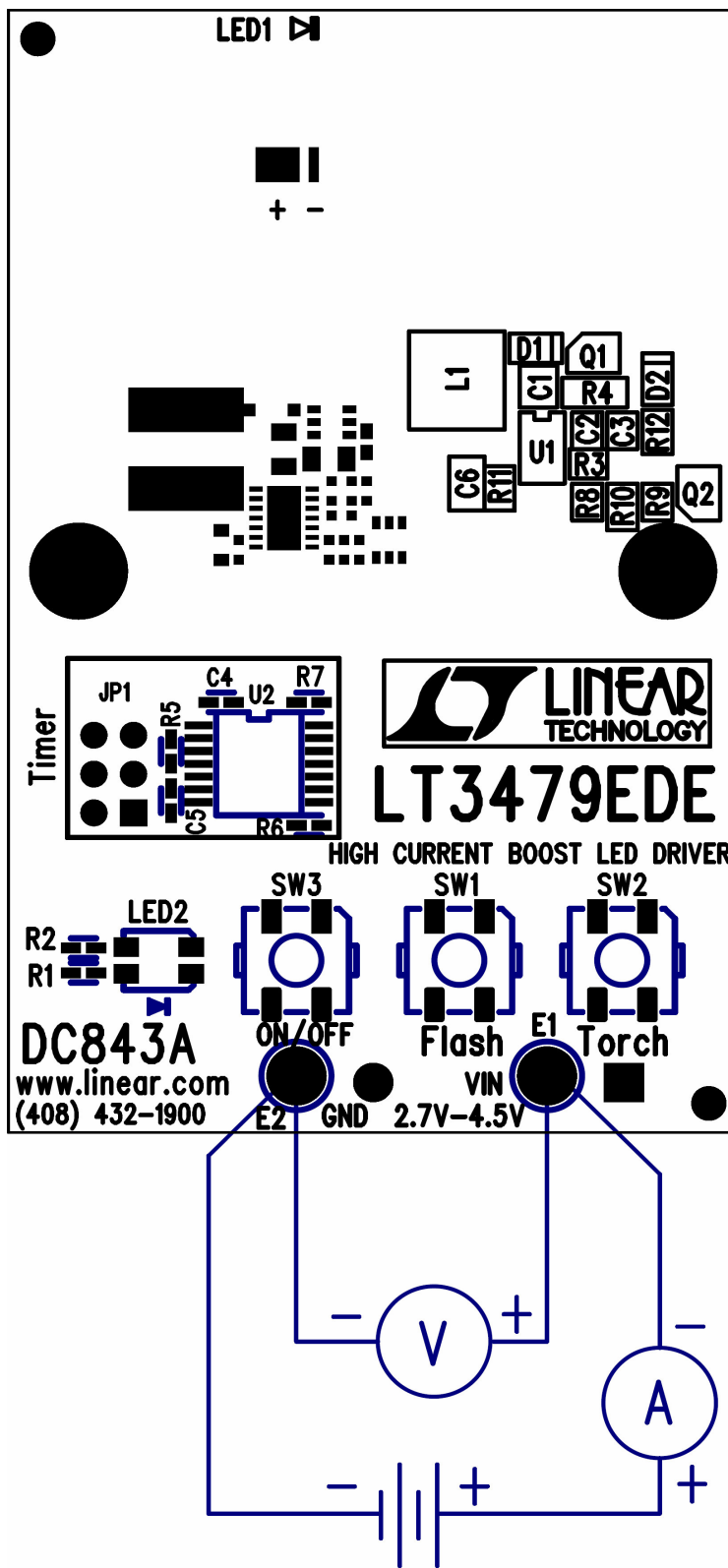
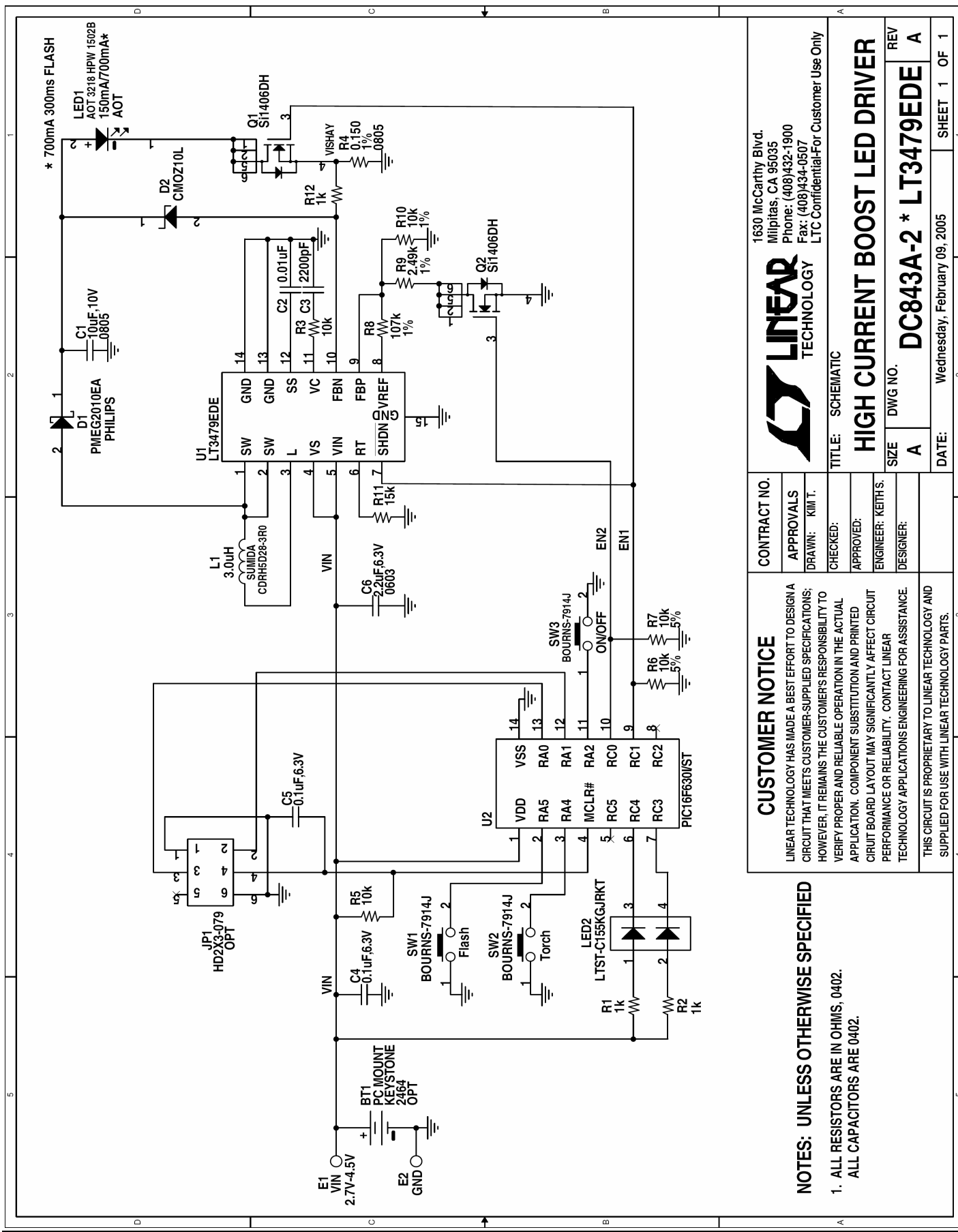

Figure 1. Proper Measurement Equipment Setup

# QUICK START GUIDE FOR DEMONSTRATION CIRCUIT 843

## HIGH CURRENT BOOST LED DRIVER



**LINEAR TECHNOLOGY**  
 1630 McCarthy Blvd.  
 Milpitas, CA 95035  
 Phone: (408)432-1900  
 Fax: (408)434-0607  
 LTC Confidential-For Customer Use Only

**LINEAR TECHNOLOGY**  
 TITLE: SCHEMATIC  
**HIGH CURRENT BOOST LED DRIVER**  
 SIZE: A  
 DWG NO.: DC843A-2 \* LT3479EDE  
 REV: A

CONTRACT NO.  
 APPROVALS  
 DRAWN: KIM T.  
 CHECKED:  
 APPROVED:  
 ENGINEER: KEITH S.  
 DESIGNER:

**CUSTOMER NOTICE**  
 LINEAR TECHNOLOGY HAS MADE A BEST EFFORT TO DESIGN A CIRCUIT THAT MEETS CUSTOMER-SUPPLIED SPECIFICATIONS; HOWEVER, IT REMAINS THE CUSTOMER'S RESPONSIBILITY TO VERIFY PROPER AND RELIABLE OPERATION IN THE ACTUAL APPLICATION. COMPONENT SUBSTITUTION AND PRINTED CIRCUIT BOARD LAYOUT MAY SIGNIFICANTLY AFFECT CIRCUIT PERFORMANCE OR RELIABILITY. CONTACT LINEAR TECHNOLOGY APPLICATIONS ENGINEERING FOR ASSISTANCE.  
 THIS CIRCUIT IS PROPRIETARY TO LINEAR TECHNOLOGY AND SUPPLIED FOR USE WITH LINEAR TECHNOLOGY PARTS.

**NOTES: UNLESS OTHERWISE SPECIFIED**  
 1. ALL RESISTORS ARE IN OHMS, 0402.  
 ALL CAPACITORS ARE 0402.

DATE: Wednesday, February 09, 2005  
 SHEET 1 OF 1