



Chipsmall Limited consists of a professional team with an average of over 10 year of expertise in the distribution of electronic components. Based in Hongkong, we have already established firm and mutual-benefit business relationships with customers from,Europe,America and south Asia,supplying obsolete and hard-to-find components to meet their specific needs.

With the principle of “Quality Parts,Customers Priority,Honest Operation,and Considerate Service”,our business mainly focus on the distribution of electronic components. Line cards we deal with include Microchip,ALPS,ROHM,Xilinx,Pulse,ON,Everlight and Freescale. Main products comprise IC,Modules,Potentiometer,IC Socket,Relay,Connector.Our parts cover such applications as commercial,industrial, and automotives areas.

We are looking forward to setting up business relationship with you and hope to provide you with the best service and solution. Let us make a better world for our industry!



## Contact us

Tel: +86-755-8981 8866 Fax: +86-755-8427 6832

Email & Skype: info@chipsmall.com Web: www.chipsmall.com

Address: A1208, Overseas Decoration Building, #122 Zhenhua RD., Futian, Shenzhen, China



## 4-/8-Channel High Speed, 24-Bit Delta Sigma ADC with Selectable Reference Inputs

### DESCRIPTION

The LTC<sup>®</sup>2447 is a 4-/8-channel, high speed, 24-bit  $\Delta\Sigma$  ADC with ten selectable speed/resolution modes from 6.9Hz/200nV<sub>RMS</sub> to 3.5kHz/25 $\mu$ V<sub>RMS</sub> (4kHz with external oscillator). Key DC specifications include 5ppm INL, 5 $\mu$ V offset, 10ppm full-scale error and 20nV/°C offset drift. In the 6.9Hz/200nV<sub>RMS</sub> mode, input normal mode rejection of 50Hz and 60Hz noise is better than 87dB. The accuracy (offset, full-scale, linearity, drift) and power dissipation are independent of the speed selected. The LTC2447 also has four reference inputs dedicated to the four differential input channels and corresponding pairs of single-ended input channels. This allows the inputs to have different reference sources, facilitating independent ratiometric measurements on each channel.

The LTC2447 performs autozeroing of the ADC by chopping the inputs through the multiplexer outputs. This allows an external dual buffer amplifier to isolate the signal inputs from the sampling current of the ADC inputs.

DC846 is a member of Linear Technology's QuikEval<sup>™</sup> family of demonstration boards. It is designed to allow easy evaluation of the LTC2447 and may be connected directly to the target application's analog signals while using the DC590 USB serial controller board and supplied software to measure performance. The exposed ground planes allow proper grounding to prototype circuitry. After evaluating with LTC's software, the digital signals can be connected to the application's processor/controller for development of the serial interface.

**Design files for this circuit board are available at <http://www.linear.com/demo>**

LT, LTC, LTM,  $\mu$ Module, Linear Technology and the Linear logo are registered trademarks and QuikEval is a trademark of Linear Technology Corporation. All other trademarks are the property of their respective owners.

## QUICK START PROCEDURE

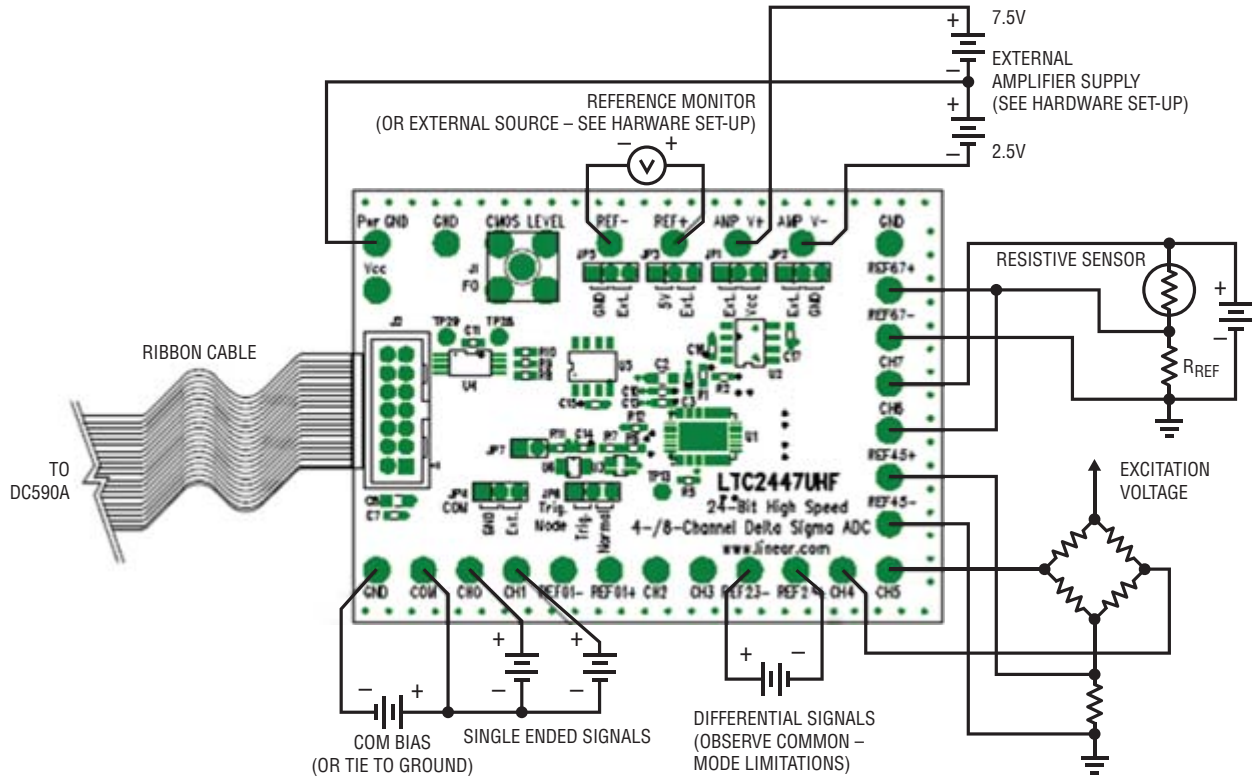

Figure 1. Connection Diagram

## QUICK START PROCEDURE

Connect DC846 to a DC590 USB Serial Controller using the supplied 14 conductor ribbon cable. Connect DC590 to host PC with a standard USB A/B cable. Run the evaluation software supplied with DC590 or downloaded from [www.linear.com/software](http://www.linear.com/software). The correct program will be loaded automatically. Click the COLLECT button to start reading the input voltage. Click the slider at the bottom

of the strip chart display to change the oversample ratio (OSR) which will in turn change the data output rate.

Tools are available for logging data, changing reference voltage, changing the number of points in the strip chart and histogram, and changing the number of points averaged for the DVM display.

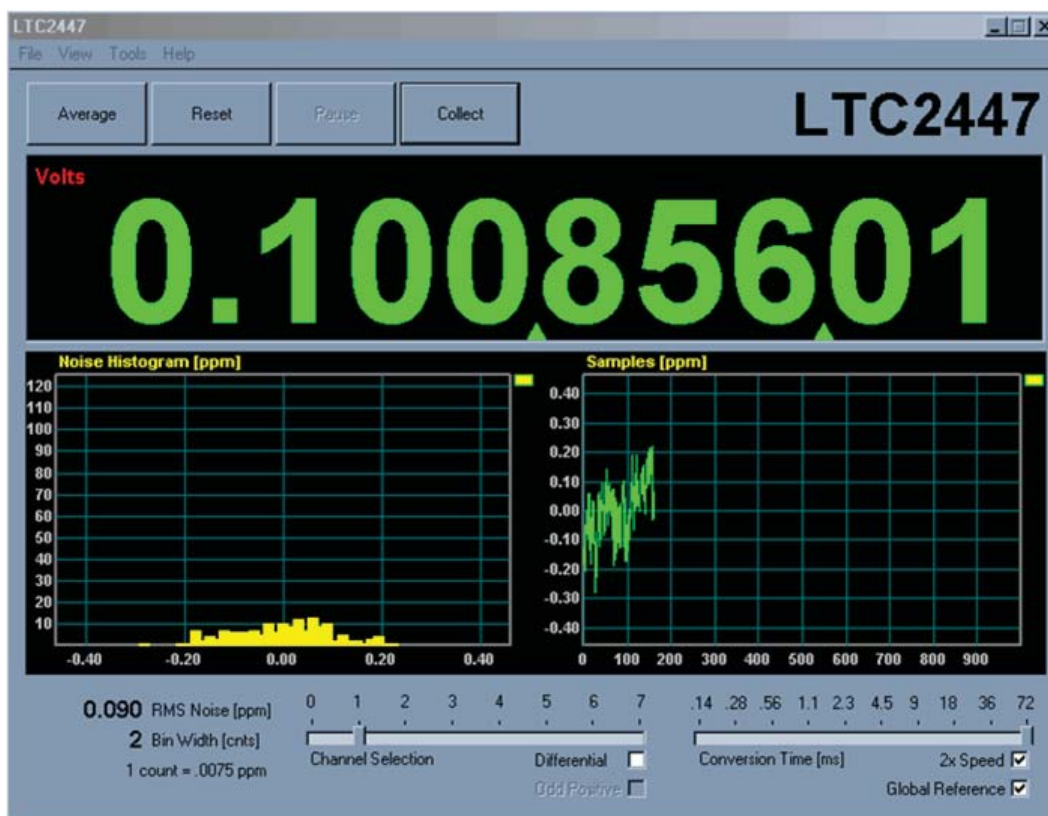

## HARDWARE SET-UP

### JUMPERS

**JP1, JP2 :** Select the positive and negative supply voltages for the onboard amplifier. Supplies can be GND and  $V_{CC}$  or supplied externally to the AMP  $V^+$  and AMP  $V^-$  turrets.

**JP3, JP5:** Select the source for REF+ and REF-, respectively. REF+ can be 5V from the onboard LT1236 reference (default) or supplied externally. REF- can be ground (0V, default) or supplied externally.

**JP4:** Select source for analog COM input, either tied to ground or supplied externally to the COM turret post.

**JP6:** Trigger mode, either normal (default) or externally triggered.

**JP7:** Trigger input signal. Pin 1 is a 5V logic signal, pin 2 is ground. When triggered mode is selected on JP3, a rising edge starts a new conversion. Note that since a conversion cannot be terminated once started, this signal can only be used to slow down the conversion rate.

### CONNECTION TO DC590 SERIAL CONTROLLER

J2 is the power and digital interface connector. Connect to DC590 serial controller with supplied 14 conductor ribbon cable.

### ANALOG CONNECTIONS

Analog signal connections are made via the row of turret posts along the edge of the board. Also, if you are connecting the board to an existing circuit, the exposed ground planes along the edges of the board may be used to form a solid connection between grounds.

**GND:** Ground turrets are connected directly to the internal analog ground plane.

**PWR GND:** Power ground, connected to the power return trace.

**$V_{CC}$ :** This is the supply for the ADC. Do not draw any power from this point. External power may be applied to this point after disabling the switching supply on DC590. If the DC590 serial controller is being used, the voltage must be regulated 5V only, as the isolation circuitry will also be powered from this supply. See the DC590 quick start guide for details.

**REF+, REF-:** These turrets are connected to the LTC2447 global reference pins (REF+ and REF-). If the onboard reference is being used, the reference voltage may be monitored from this point. An external reference may be connected to these terminals if JP3 and JP5 are configured for external reference.

**REF01+, REF01-, REF23+, REF23-, etc.:** dedicated reference inputs for each input channel.

**Note:** The REF+, REF-, REF01+, REF01-, REF23+, REF23-, etc. terminals are decoupled to ground with 0.1 $\mu$ F and 10 $\mu$ F capacitors. Thus any source connected to these terminals must be able to drive a capacitive load and have very low impedance at DC. Examples are series references that require an output capacitor and C-load stable op amps such as the LT1219 and LT1368.

**CH0-CH7:** These are the differential inputs to the LTC2447. They may be configured either as single-ended inputs with respect to the COM pin, or adjacent pairs may be configured as differential inputs (CH0 to CH1, CH2 to CH3, etc.)

## EXPERIMENTS

### INPUT NOISE

Solder a short wire from the CH0 to CH1. Ensure that the buffer amplifiers are in their active region of operation by either biasing the inputs to mid-supply with a 10k to 10k divider when the buffer amplifier is powered from  $V_{CC}$  and ground, or tie the inputs to ground and connect an external 7.5V/–2.5V supply to the AMPV- turret (JP1 and JP2 must be set to EXT.)

Set the demo software to OSR32768 (6.8 samples per second) and check the 2× box. Noise should be approximately 0.04ppm of  $V_{REF}$  (200nV.) Next, select different oversample ratios. Measured noise for each oversample ratio should be close to values given in the LTC2447 data sheet.

### COMMON MODE REJECTION

Tie the two inputs (still connected together from previous experiment) to ground through a short wire and note the indicated voltage. Tie the inputs to REF+; the difference should be less than 5 $\mu$ V due to the 120dB CMRR of the LTC2447.

This experiment requires an external power supply to the buffer amplifier.

If the common mode voltage is limited to GND +0.25V to  $V_{CC}$ -0.25V, this test may be performed with the amplifier supplies set to ground and  $V_{CC}$ .

### INPUT NORMAL MODE REJECTION

The LTC2447's SINC4 digital filter is trimmed to strongly reject both 50Hz and 60Hz line noise when operated with the internal conversion clock and oversample ratio 32768 (6.8 samples per second.) To measure input normal mode rejection, connect COM to a 2.5V source such as an LT1790-2.5 reference or a power supply. Connect any other input (CH0 to CH15) to the same supply through a 10k resistor. Apply a 10Hz, 2V peak-to-peak sine wave to the input through a 1 $\mu$ F capacitor.

Select OSR32768 (6.8 samples per second) and 2× mode in the demo software and start taking data. The input noise will be quite large, and the graph of output vs time should show large variations.

Next, slowly increase the frequency to 55Hz. The noise should be almost undetectable in the graph. Note that the indicated noise in ppm may still be above that of the data sheet specification because the inputs are not connected to a DC source.

Change the OSR to 16384 (13.75 samples per second); the noise will increase substantially, as the first notch at this OSR is at 110Hz. Increase the signal generator frequency to 110Hz, the noise will drop again.

# DEMO MANUAL DC846A

## PARTS LIST

ITEM	QTY	REFERENCE	PART DESCRIPTION	MANUFACTURER/PART NUMBER
1	4	C3, C7, C10, C13	CAP, CHIP X7R, 0.01 $\mu$ F, 16V	AVX, 0603YC103KAT1A 0603
2	7	C4, C6, C11, C14-C17	CAP, CHIP X7R, 0.1 $\mu$ F, 16V	AVX, 0603YC104MAT1A 0603
3	8	C1, C5, C18-C23	CAP, CHIP X5R, 1 $\mu$ F, 10V	TAIYO YUDEN, LMK107BJ105MG 0603
4	3	C2, C9, C12	CAP, CHIP X5R, 4.7 $\mu$ F, 6.3V	TAIYO YUDEN, JMK212BJ475MG 0805
5	1	C8	CAP, CHIP X5R, 10 $\mu$ F, 6.3V	TDK, C2012X5R0J106M 0805
6	26	TP1-TP12, TP14-TP27	TURRET, Testpoint .064"	MILL-MAX, 2308-2
7	0	TP13, TP28, TP29	Opt. (Surface Mount Pad Only)	
8	6	JP1-JP6	HEADER, 3-Pin, 1 Row .079CC	COMM-CON, 2802S-03G2
9	6	FOR (JP1-JP6)	SHUNT, .079" Center	COMM-CON, CCIJ2MM-138GW
10	0	JP7	Opt.	
11	0	J1 (Opt.)	CONN., SMA Coaxial, Straight Jack	CONNEX, 132134
12	1	J2	HEADER, Vertical Dual, 2 $\times$ 7 .079CC	MOLEX, 87831-1420
13	2	D1, D2	DIODE, SMT SCHOTTKY BARRIER	DIODES INC. BAT54S SOT-23
14	2	R1, R2	RES., CHIP 0	VISHAY CRCW0603 0 $\Omega$
15	1	R7	RES., CHIP 100, 5%	AAC, CR16-101JM 0603
16	3	R8, R9, R10	RES., CHIP 4.99k 1%	VISHAY CRCW0603 4.99k 1%
17	2	R5, R11	RES., CHIP 10k 5%	AAC, CR16-103JM 0603
18	0	R6	Opt.	
19	1	U2	I.C., Operational Amplifier	LINEAR TECH., LT1368CS8 SO8
20	1	U1 (4 tubes)	I.C., 24-Bit Delta Sigma ADC	LINEAR TECH., LTC2447UHF 38QFN
21	1	U5	I.C., Precision Reference	LINEAR TECH., LT1236ACS8-5 SO8
22	1	U4	I.C., Serial EEPROM	MICROCHIP, 24LC025-I/ST TSSOP-8
23	1	U3	I.C., Non-Inverting Multiplexer	FAIRCHILD, NC7SZ157P6X SC70
24	1	U6	I.C., Single D Flip-Flop	On Semi. NL17SZ74US US8
23	1	(FOR INVENTORY ONLY).	CABLE ASSY., 8" STRIP	LINEAR RIBBON CABLE CA-2440

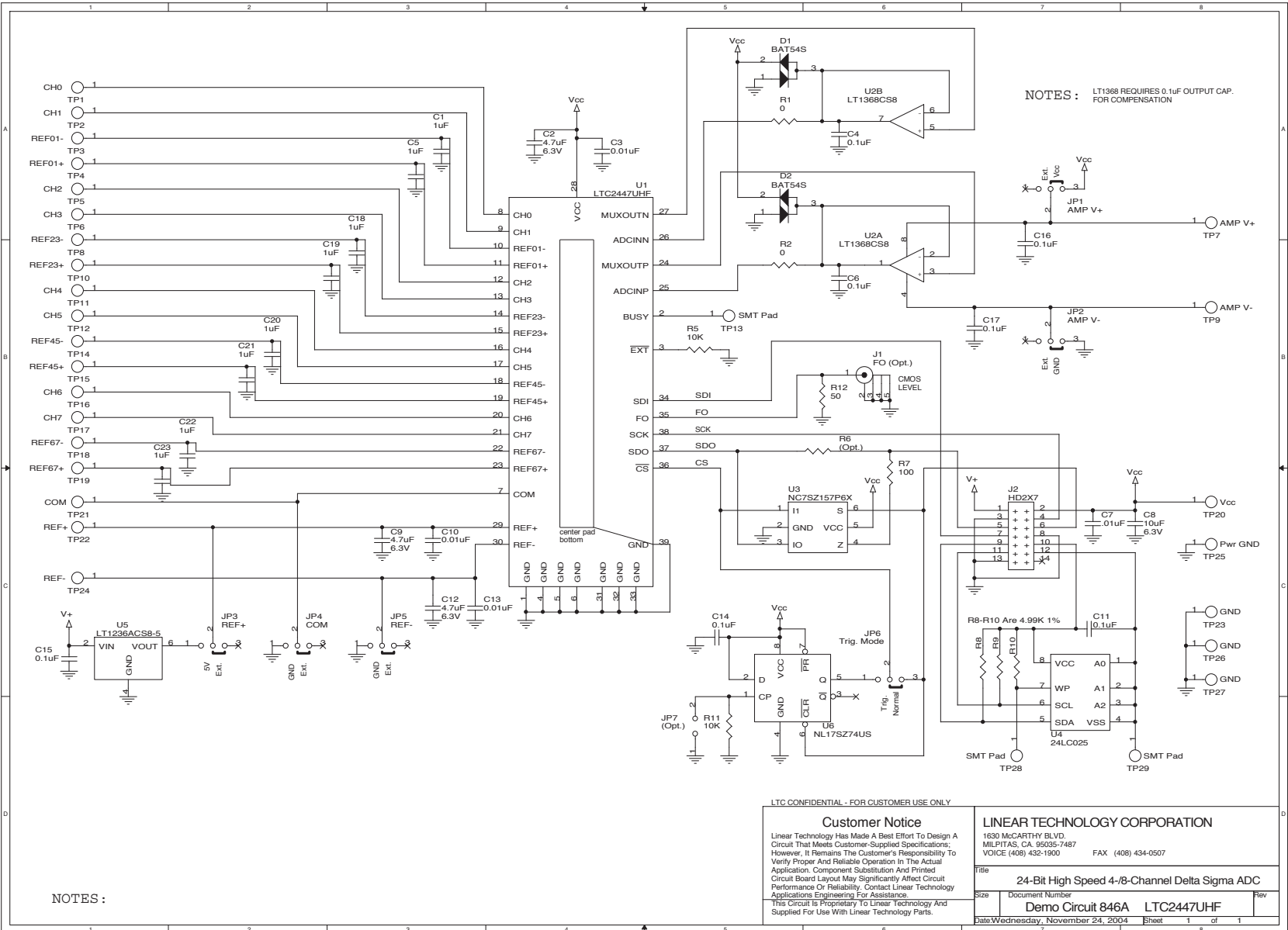

NOTES:



# DEMO MANUAL DC846A

---

## DEMONSTRATION BOARD IMPORTANT NOTICE

Linear Technology Corporation (LTC) provides the enclosed product(s) under the following **AS IS** conditions:

This demonstration board (DEMO BOARD) kit being sold or provided by Linear Technology is intended for use for **ENGINEERING DEVELOPMENT OR EVALUATION PURPOSES ONLY** and is not provided by LTC for commercial use. As such, the DEMO BOARD herein may not be complete in terms of required design-, marketing-, and/or manufacturing-related protective considerations, including but not limited to product safety measures typically found in finished commercial goods. As a prototype, this product does not fall within the scope of the European Union directive on electromagnetic compatibility and therefore may or may not meet the technical requirements of the directive, or other regulations.

If this evaluation kit does not meet the specifications recited in the DEMO BOARD manual the kit may be returned within 30 days from the date of delivery for a full refund. **THE FOREGOING WARRANTY IS THE EXCLUSIVE WARRANTY MADE BY THE SELLER TO BUYER AND IS IN LIEU OF ALL OTHER WARRANTIES, EXPRESSED, IMPLIED, OR STATUTORY, INCLUDING ANY WARRANTY OF MERCHANTABILITY OR FITNESS FOR ANY PARTICULAR PURPOSE. EXCEPT TO THE EXTENT OF THIS INDEMNITY, NEITHER PARTY SHALL BE LIABLE TO THE OTHER FOR ANY INDIRECT, SPECIAL, INCIDENTAL, OR CONSEQUENTIAL DAMAGES.**

The user assumes all responsibility and liability for proper and safe handling of the goods. Further, the user releases LTC from all claims arising from the handling or use of the goods. Due to the open construction of the product, it is the user's responsibility to take any and all appropriate precautions with regard to electrostatic discharge. Also be aware that the products herein may not be regulatory compliant or agency certified (FCC, UL, CE, etc.).

No License is granted under any patent right or other intellectual property whatsoever. **LTC assumes no liability for applications assistance, customer product design, software performance, or infringement of patents or any other intellectual property rights of any kind.**

LTC currently services a variety of customers for products around the world, and therefore this transaction **is not exclusive**.

**Please read the DEMO BOARD manual prior to handling the product.** Persons handling this product must have electronics training and observe good laboratory practice standards. **Common sense is encouraged.**

This notice contains important safety information about temperatures and voltages. For further safety concerns, please contact a LTC application engineer.

Mailing Address:

Linear Technology  
1630 McCarthy Blvd.  
Milpitas, CA 95035

Copyright © 2004, Linear Technology Corporation