



Chipsmall Limited consists of a professional team with an average of over 10 year of expertise in the distribution of electronic components. Based in Hongkong, we have already established firm and mutual-benefit business relationships with customers from,Europe,America and south Asia,supplying obsolete and hard-to-find components to meet their specific needs.

With the principle of “Quality Parts,Customers Priority,Honest Operation,and Considerate Service”,our business mainly focus on the distribution of electronic components. Line cards we deal with include Microchip,ALPS,ROHM,Xilinx,Pulse,ON,Everlight and Freescale. Main products comprise IC,Modules,Potentiometer,IC Socket,Relay,Connector.Our parts cover such applications as commercial,industrial, and automotives areas.

We are looking forward to setting up business relationship with you and hope to provide you with the best service and solution. Let us make a better world for our industry!



Contact us

Tel: +86-755-8981 8866 Fax: +86-755-8427 6832

Email & Skype: info@chipsmall.com Web: www.chipsmall.com

Address: A1208, Overseas Decoration Building, #122 Zhenhua RD., Futian, Shenzhen, China



WARNING!

DO NOT LOOK AT OPERATING LED.
 This circuit produces light that can damage eyes.

DESCRIPTION

Demonstration circuit 905 is a LED Driver in SC70 With Built-in Schottky featuring the LT3491. The LT3491 is a fixed frequency step-up current mode DC/DC converter. There are two circuits on demonstration board 905. The “Small Size” circuit generates 15mA LED current at the smallest possible solution size. The “High Efficiency” circuit generates 20mA LED current at higher efficiency. The circuit outputs share 6 LEDs. At any given time, depending on the positions of jumpers, only one circuit is in operation. Other features of the LT3491, such as the internal schottky diode, the high switching frequency and the internal open circuit protection, allow tiny components for both circuits. The input range of the demo board is from 3V to 5V. Different dimming controls can

be implemented on the demo board. Please refer to the quick start procedure. The high side current sensing feature of the LT3491 allows “one wire” current source, i.e. the low side of the LED string can return to ground anywhere.

The LT3491 datasheet gives a complete description of the part, operation and application information. The datasheet must be read in conjunction with this quick start guide for working on or modifying demo circuit 905.

Design files for this circuit board are available. Call the LTC factory.

LTC, LTC and LT are registered trademarks of Linear Technology Corporation. ThinSOT and PowerPath are trademarks of Linear Technology Corporation.

PERFORMANCE SUMMARY

Specifications are at $T_A = 25^\circ\text{C}$

SYMBOL	PARAMETER	CONDITIONS	MIN	TYP	MAX	UNITS
V_{IN}	Input Supply Range **		3		5	V
I_{OUT}	Output Current	Small Size circuit High Efficiency circuit	14.25 19	15 20	15.75 21	mA
V_{OUT}	Output Voltage	Small Size circuit High Efficiency circuit		20.3 20.6		V
η	Efficiency	$V_{IN} = 4.2\text{V}$, Small Size circuit $V_{IN} = 4.2\text{V}$, High Efficiency circuit		73.6 75.5		%
V_{OPEN}	CAP pin Over-voltage Protection	LED Open	26	27	28	V
I_Q	Quiescent Current	$V_{IN} = 4.2\text{V}$, CTRL = ON			4	mA
I_{QSHDN}	Quiescent Current While in Shutdown	$V_{IN} = 4.2\text{V}$, CTRL = OFF			10	μA
F_s	Switching Frequency		1.8	2.3	2.8	MHz

** The Input Supply Range of demo circuit 905 is limited by the input capacitors. The input voltage absolute maximum rating of the LT3491 is 12V.

QUICK START PROCEDURE

Demonstration circuit 905 is easy to set up to evaluate the performance of the LT3491. Refer to Figure 1 for proper measurement equipment setup and follow the procedure below:

NOTE . When measuring the input or output voltage ripple, care must be taken to avoid a long ground lead on the oscilloscope probe. Measure the input or output voltage ripple by touching the probe tip directly across the Vin or Vout and GND terminals. See Figure 2 for proper scope probe technique.

1. Place jumpers in the following positions to test the "SMALL SIZE" circuit:

JP1	ON
JP2	OFF
JP3	SIZE
JP4	SIZE

2. Place jumpers in the following positions to test the "HIGH EFFICIENCY" circuit:

JP1	OFF
JP2	ON
JP3	EFFICIENCY
JP4	EFFICIENCY

3. Prior to connection, preset the input power supply to the desired voltage (3V to 5V). With power off, connect the input power supply to VIN and GND.

4. Turn on the power at the input.

NOTE . Make sure that the input voltage does not exceed 5V.

5. Check for the proper voltages and currents.

NOTE . If the LEDs do not light up, check all the jumper settings.

6. Once proper operation is established, adjust the input within the operating range and observe the parameters of interest.

7. To test the filtered PWM dimming or the direct DC dimming, remove the jumper JP1 or JP2, apply the PWM or the DC signal to the CTRL1 or CTRL2 and observe the brightness of the LED output.

8. To test the direct PWM dimming, follow the Direct PWM Dimming section in the datasheet.

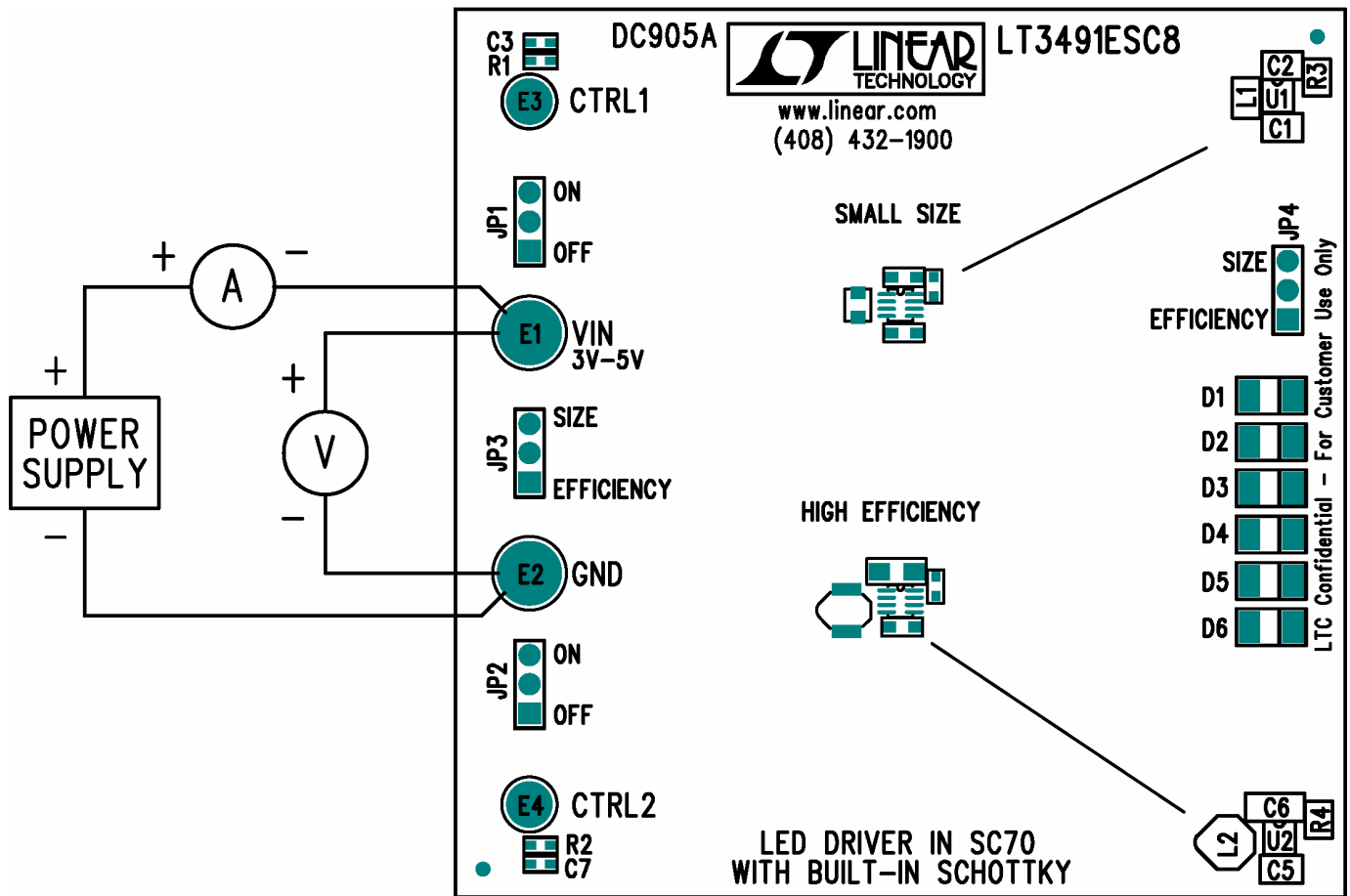

Figure 1. Proper Measurement Equipment Setup

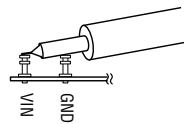
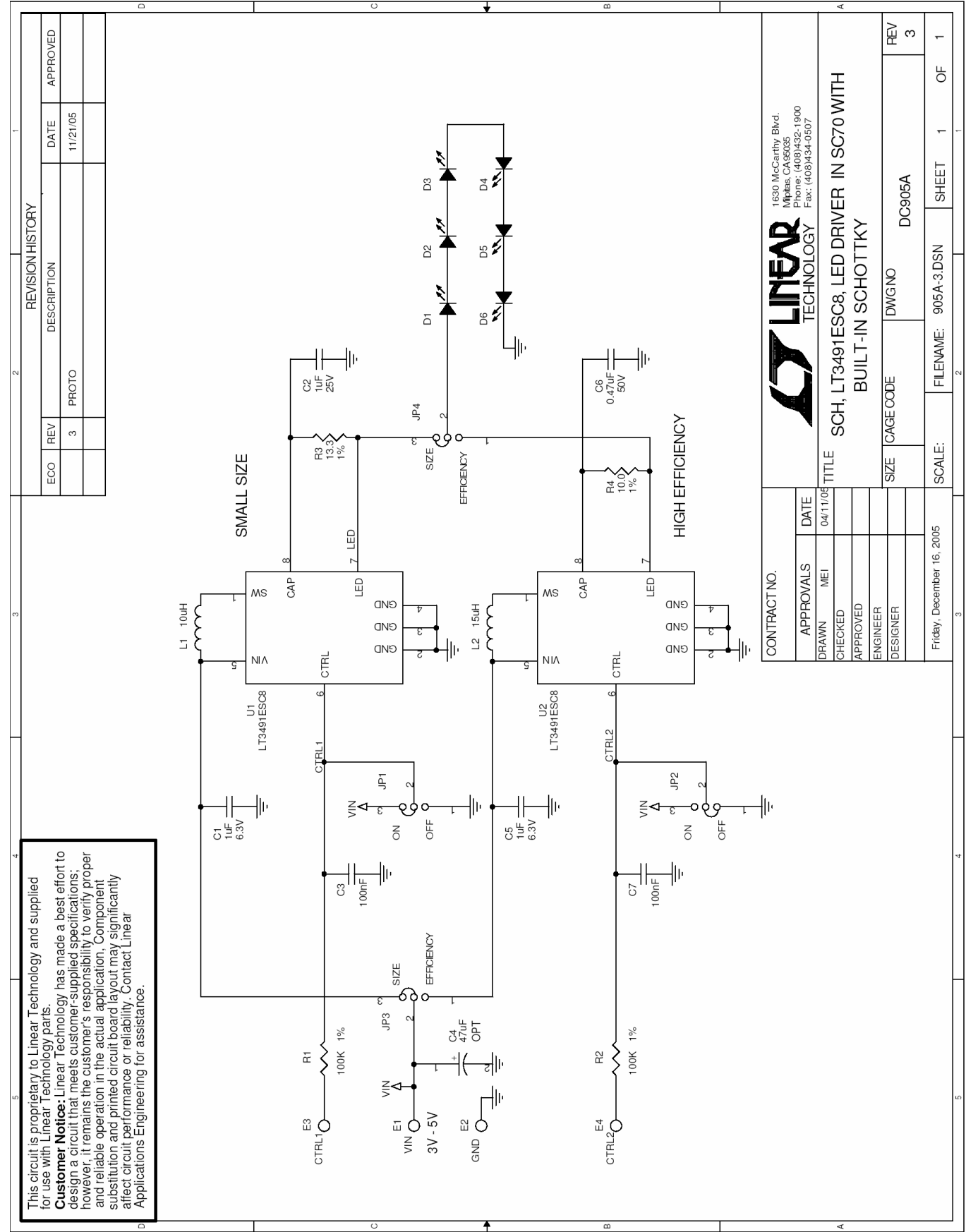

Figure 2. Measuring Input or Output Ripple



This circuit is proprietary to Linear Technology and supplied for use with Linear Technology parts.
Customer Notice: Linear Technology has made a best effort to design a circuit that meets customer-supplied specifications; however, it remains the customer's responsibility to verify proper and reliable operation in the actual application. Component substitution and printed circuit board layout may significantly affect circuit performance or reliability. Contact Linear Applications Engineering for assistance.

REVISION HISTORY				
ECO	REV	DESCRIPTION	DATE	APPROVED
	3	PROTO	11/21/05	

		1650 McCarthy Blvd. Milpitas, CA 95035 Phone: (408)432-1900 Fax: (408)434-0507	
CONTRACT NO.		TITLE	SCH, LT3491ESC8, LED DRIVER IN SC70 WITH BUILT-IN SCHOTTKY
APPROVALS	DATE	SIZE	CAGE CODE
DRAWN MEI	04/11/05	DWGNO	DC905A
CHECKED		SCALE:	905A-3.DSN
APPROVED		FILENAME:	905A-3.DSN
ENGINEER		SHEET	1 OF 1
DESIGNER		REV	3
Friday, December 16, 2005			