



Chipsmall Limited consists of a professional team with an average of over 10 year of expertise in the distribution of electronic components. Based in Hongkong, we have already established firm and mutual-benefit business relationships with customers from,Europe,America and south Asia,supplying obsolete and hard-to-find components to meet their specific needs.

With the principle of “Quality Parts,Customers Priority,Honest Operation,and Considerate Service”,our business mainly focus on the distribution of electronic components. Line cards we deal with include Microchip,ALPS,ROHM,Xilinx,Pulse,ON,Everlight and Freescale. Main products comprise IC,Modules,Potentiometer,IC Socket,Relay,Connector.Our parts cover such applications as commercial,industrial, and automotives areas.

We are looking forward to setting up business relationship with you and hope to provide you with the best service and solution. Let us make a better world for our industry!



## Contact us

Tel: +86-755-8981 8866 Fax: +86-755-8427 6832

Email & Skype: info@chipsmall.com Web: www.chipsmall.com

Address: A1208, Overseas Decoration Building, #122 Zhenhua RD., Futian, Shenzhen, China



## DESCRIPTION

Demonstration circuit DC915 features LT3466-1 high efficiency white LED driver and step-up converter. There is one LED driver output for 8 WLEDs and 2 normal outputs for LCD. VO1 drives 8 LEDs in series with 15mA LED current and VO2/VO3 can delivery +/- 15V at 10mA current. If the charge-pump circuitry (C4, C5 and D1), which generates VO3, is removed, VO2 can deliver over 35mA of current. The input voltage range is 3V to 14V, which can go as low as 2.7V with slightly reduced output current.

Each output channel has a jumper (JP1 or JP2) for enabling the output(s) and a CTRL pin (CTRL1 or CTRL2) for LED brightness (current) control or VO2/VO3 voltage adjustment. Placing the jumpers to "/SD" turns off the WLEDs or VO2/VO3, and jumpers to "EN" enables the selected channel of the LT3466-1. Modulating the voltage at CTRL1 or CTRL2 pin respectively can change the LED current at VO1 or VO2/VO3 voltages. As the volt-

age on the CTRL1 pin increases from 0V to 1.6V, the feedback voltage across the LED current programming resistor increases from 0 to 200mV, varying the LED current from 0 to 15mA. Similarly, VO2/VO3 voltages increase with voltage on CNTL2. The "CTRL to FB" curves are show in the datasheet.

JP3 can conveniently set 8 WLEDs (JP3 jumper at top position), 6 WLEDs (JP3 jumper at bottom position), or open circuit protection test (no jumper), while FB1 terminal monitors the WLED current (VFB1/R1).

The overall solution occupies less than 1.62 cm<sup>2</sup> with components on one side of the PCB.

**Design files for this circuit board are available. Call the LTC factory.**

---

LT is a trademark of Linear Technology Corporation

**Table 1. Performance Summary (T<sub>A</sub> = 25°C unless otherwise noted)**

PARAMETER FOR LED DRIVER	CONDITION	VALUE
Minimum Input Voltage		3V
Maximum Input Voltage		14V
LED Current	With R1=13.3 ohms	15mA
VO2		15V/10mA
VO3		-14.5V/10mA
Typical Overall Efficiency	3.6V input	82%
Typical Switching Frequency	With 63.4KΩ timing resistor	800kHz
Typical Shutdown Current	3.6V input, both boost shutdown	27uA
Typical OVP at VO1	LED string open	39.5V

## QUICK START PROCEDURE

DC915 is easy to set up to evaluate the performance of the LT3466-1. Refer to Figure 1 for proper measurement equipment setup and follow the procedure below:

1. With power off, connect the input power supply PS1 to **VIN** and **GND**. Make sure JP1 and JP2 are set to “EN” positions and JP3 to “8LEDS” (default).
2. Set the input supply at 3.6V. Turn on the power at the input.
3. Observe all white LEDs light up with uniform brightness. The output voltage should measure about 26.5V, FB1 200mV, VO2 15V, and VO3 -14.5V.
4. Test the shutdown function by placing the jumper JP1 to /SD1. Observe LEDs turn off.
5. The LED brightness is controlled by DC voltage PS2 at CTRL1 terminal. With jumper removed from JP1, observe the LED brightness change with DC voltage applied to CNTRL1 pin. The voltage range recommended for dimming is 200mV ~ 1.6V. See the LT3466-1 data sheet for more information on dimming control.
6. Remove PS1 and place the jumper back on JP1 at “EN1” to enable “OVP Test” of the LED string. When jumper on JP3 is removed, VO1 shows the open circuit protection voltage (about 39.5V). When jumper is placed to bottom terminals, only 6 WLEDs light up.
7. When JP2 is set to /SD2, VO2 goes to slightly less than  $V_{in}$ , and VO3 to 0. When both channels are set to the /SD state, the total shut-down current is about 27 $\mu$ A at  $V_{in}$ =3.6V. It increases slightly with  $V_{in}$ .
8. VO2 and VO3 are controlled the same way as the VFB1 vs. VCNTRL1.

**Note:** LT3466-1 can operate up to 22V (it needs to be 1-2V lower than output voltage for the boost converter to work properly).

# QUICK START GUIDE FOR DEMONSTRATION CIRCUIT DC915

## WLED DRIVER & LCD BIAS

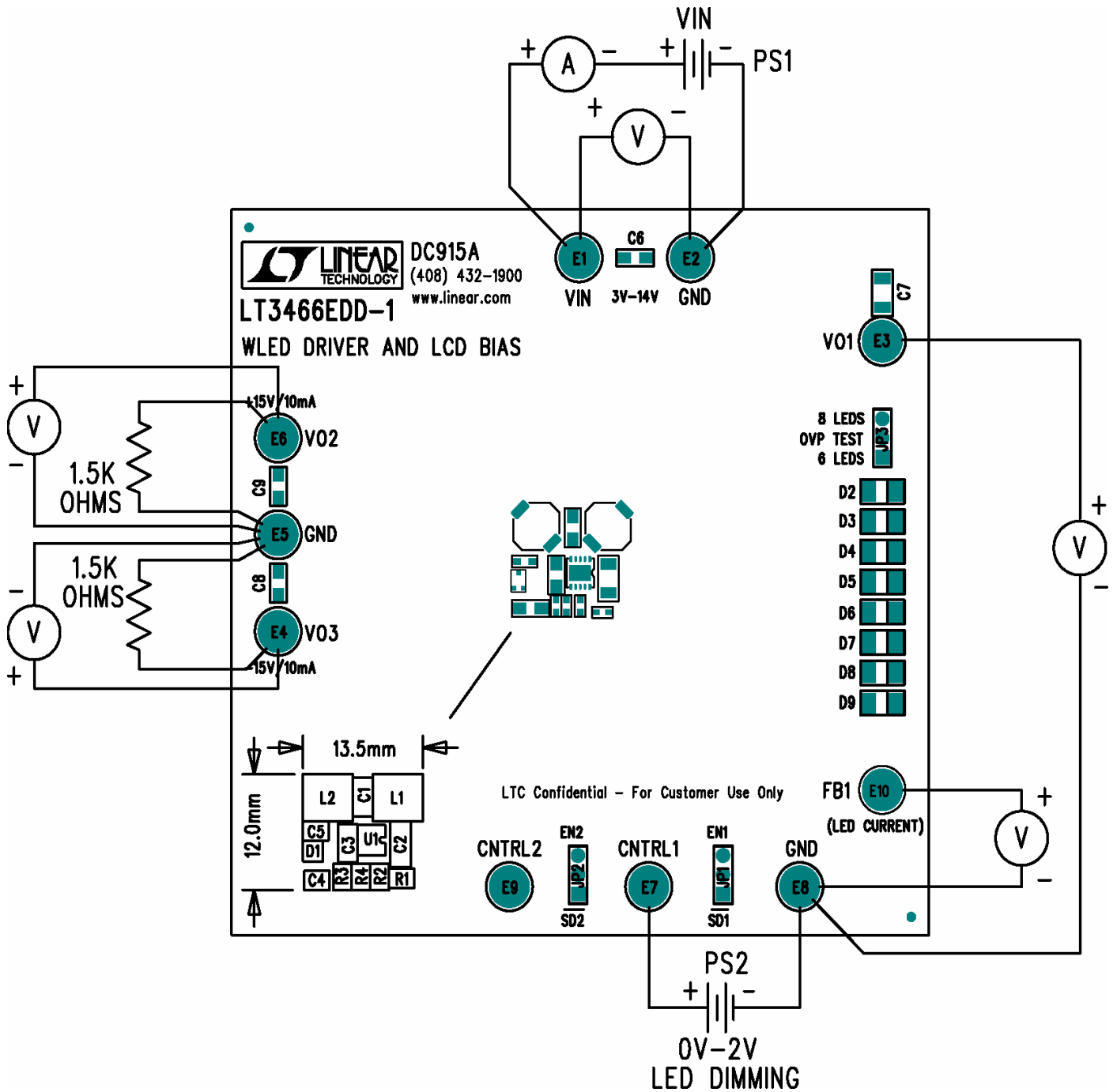
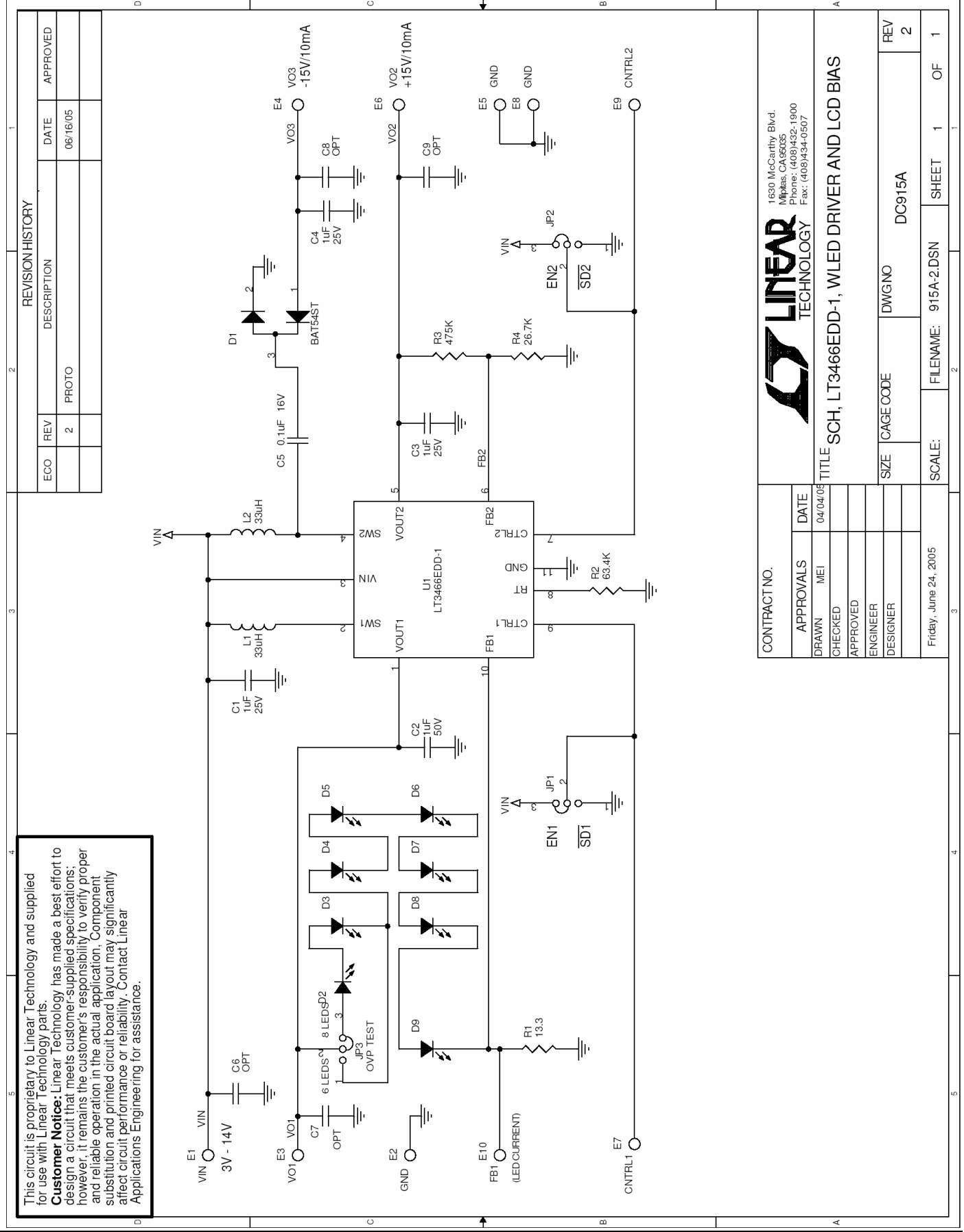

Figure 1. Test Connection Diagram

# QUICK START GUIDE FOR DEMONSTRATION CIRCUIT DC915

## WLED DRIVER & LCD BIAS



This circuit is proprietary to Linear Technology and supplied for use with Linear Technology parts.  
**Customer Notice:** Linear Technology has made a best effort to design a circuit that meets customer-supplied specifications; however, it remains the customer's responsibility to verify proper and reliable operation in the actual application. Component substitution and printed circuit board layout may significantly affect circuit performance or reliability. Contact Linear Applications Engineering for assistance.

### REVISION HISTORY

ECO	REV	DESCRIPTION	DATE	APPROVED
	2	PROTO	06/16/05	

CONTRACT NO.		APPROVALS	DATE
		DRAWN MEI	04/04/05
		CHECKED	
		APPROVED	
		ENGINEER	
		DESIGNER	
Friday, June 24, 2005			

		1630 McCarthy Blvd. Milpitas, CA 95035 Phone: (408)432-1900 Fax: (408)434-0507	
TITLE SCH, LT3466EDD-1, WLED DRIVER AND LCD BIAS			
SIZE	CAGE CODE	DWGNO	REV
		DC915A	2
SCALE:	FILENAME:	SHEET	OF
	915A-2.DSN	1	1