



Chipsmall Limited consists of a professional team with an average of over 10 year of expertise in the distribution of electronic components. Based in Hongkong, we have already established firm and mutual-benefit business relationships with customers from,Europe,America and south Asia,supplying obsolete and hard-to-find components to meet their specific needs.

With the principle of “Quality Parts,Customers Priority,Honest Operation,and Considerate Service”,our business mainly focus on the distribution of electronic components. Line cards we deal with include Microchip,ALPS,ROHM,Xilinx,Pulse,ON,Everlight and Freescale. Main products comprise IC,Modules,Potentiometer,IC Socket,Relay,Connector.Our parts cover such applications as commercial,industrial, and automotives areas.

We are looking forward to setting up business relationship with you and hope to provide you with the best service and solution. Let us make a better world for our industry!



## Contact us

Tel: +86-755-8981 8866 Fax: +86-755-8427 6832

Email & Skype: info@chipsmall.com Web: www.chipsmall.com

Address: A1208, Overseas Decoration Building, #122 Zhenhua RD., Futian, Shenzhen, China



# LTC2483

## 16-Bit Delta Sigma ADC with Easy Drive™ Input Current Cancellation and I<sup>2</sup>C Interface

### DESCRIPTION

Demonstration circuit 955A features the **LTC®2483**, a 16-bit high performance  $\Delta\Sigma$  analog-to-digital converter (ADC). The LTC2483 features 2ppm linearity, 0.5 $\mu$ V offset, and 600nV<sub>RMS</sub> noise. The input is fully differential, with input common mode rejection of 140dB. The LTC2483 is available in a 10-pin DFN package and has an easy to use I<sup>2</sup>C interface.

DC955A is a member of Linear Technology's QuikEval™ family of demonstration boards. It is designed to allow easy evaluation of the LTC2483 and may be connected directly to the target application's analog signals while using the

DC590 USB Serial Controller board and supplied software to measure performance. The exposed ground planes allow proper grounding to prototype circuitry. After evaluating with Linear Technology's software, the digital signals can be connected to the end application's processor/controller for development of the serial interface.

**Design files for this circuit board are available at <http://www.linear.com/demo>**

LT, LT, LTC, LTM, Linear Technology and the Linear logo are registered trademarks and Easy Drive and QuikEval are trademarks of Linear Technology Corporation. All other trademarks are the property of their respective owners.

### BOARD PHOTO

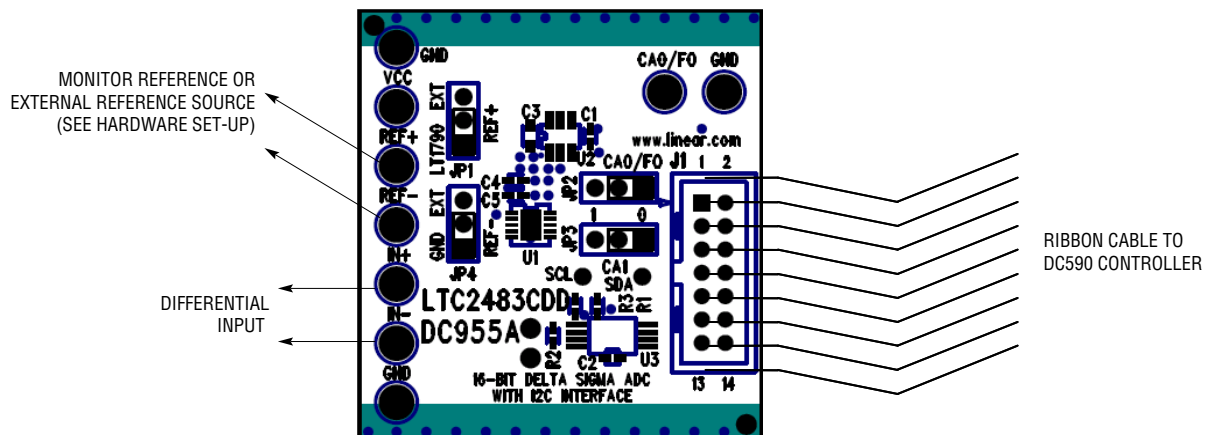

Figure 1. Proper Measurement Equipment Setup

## QUICK START PROCEDURE

Connect DC955A to a DC590 USB Serial Controller using the supplied 14-conductor ribbon cable. Connect DC590 to host PC with a standard USB A/B cable. Run the evaluation software supplied with DC590 or downloaded from <http://www.linear.com/software>. The correct program will be loaded automatically. Click the COLLECT button to start

reading the input voltage. Details on software features are documented in the control panel's help menu.

Tools are available for logging data, changing reference voltage, changing the number of points in the strip chart and histogram, and changing the number of points averaged for the DVM display.

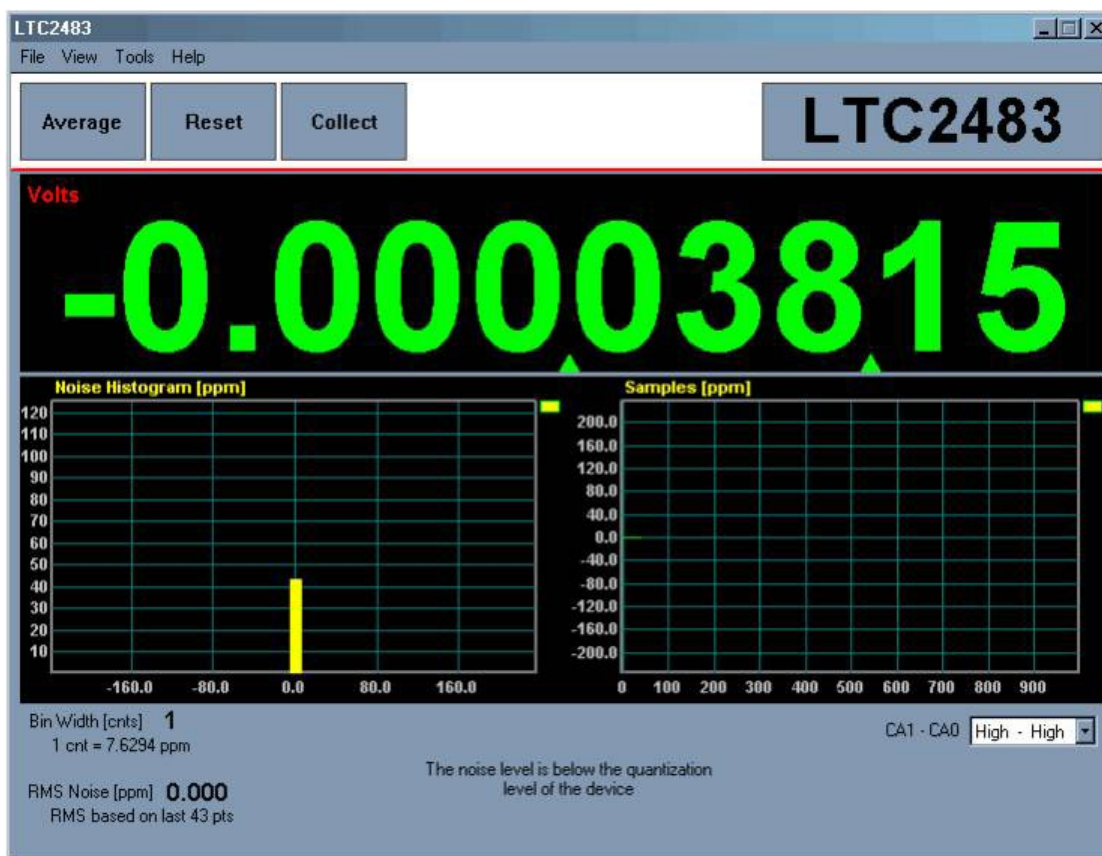

Figure 2. Software Screenshot

## HARDWARE SETUP

### Connection to DC590 Serial Controller

J1 is the power and digital interface connector. Connect to DC590 serial controller with supplied 14-conductor ribbon cable.

### Jumpers

**JP1:** Select the source for REF<sup>+</sup>, either an LT1790-5, or externally supplied.

**JP4:** Select the source for REF<sup>-</sup>, either Ground (GND) or externally supplied.

**JP2, JP3:** I<sup>2</sup>C Address Selection. These pins are connected to CA0/f<sub>0</sub> and CA1, respectively. Refer to the LTC2483 data sheet for address mapping.

### Analog Connections

Analog signal connections are made via the row of turret posts along the edge of the board. Also, when connecting the board to an existing circuit the exposed ground planes along the edges of the board may be used to form a solid connection between grounds.

**GND:** Three ground turrets are connected directly to the internal ground planes.

**V<sub>CC</sub>:** This is the supply for the ADC. Do not draw any power from this point.

**REF<sup>+</sup>:** Connected to the LTC2483 REF<sup>+</sup> pin. If the onboard reference is being used, the reference voltage may be monitored from this point. An external reference may be connected to these terminals if JP1 is removed.

**REF<sup>-</sup>:** Connected to the LTC2483 REF<sup>-</sup> pin. Normally at ground when JP4 is set to GND.

**IN<sup>+</sup>, IN<sup>-</sup>:** These are the differential inputs to the LTC2483.

**CA0/f<sub>0</sub>:** IMPORTANT—Remove JP2 before applying signals to this turret. An external conversion clock may be applied to the CA0/f<sub>0</sub> turret to modify the frequency rejection characteristics or data output rate of the LTC2483. This should be a square wave with a low level equal to ground and a high level equal to V<sub>CC</sub>. While up to a 2MHz clock can be used, performance may be compromised. Refer to the LTC2483 data sheet.

## EXPERIMENTS

### Input Noise

One of the characteristics of the LTC2483 is that the 600nV input noise floor is far below the quantization level of 38μV when a 5V reference is used. This means that the output will be stable if the input noise level is significantly below 38μV. In this sense, the LTC2483 is a true 17 effective bit part, whereas many 16-bit SAR converters have several LSBs of noise.

Solder a short wire from the IN<sup>-</sup> turret post to the IN<sup>+</sup> turret post. Noise should be below the quantization level of the LTC2483. This will result in a noise reading of zero on the control software, unless the offset is such that the display flickers between two codes in which case the RMS noise reading will be incorrect.

Select EXT for the source for V<sub>REF</sub> on JP1 and apply a 100mV source between a GND turret post and the V<sub>REF</sub> turret post. A precision, adjustable voltage source such as a Data Precision 8200 or Fluke 332A is ideal. Another option for this experiment is a 50k/1k divider from the LT1790A-5 output to ground, giving a 98mV output. The resulting LSB size is 0.1/217, or 763nV. This is small enough to see the noise floor of the LTC2483 inputs, and the RMS noise display should read approximately 6 to 7ppm (of the 100mV reference).

### Common Mode Rejection

Tie the two inputs (still connected together) to ground through a short wire and note the indicated voltage. Tie the inputs to REF<sup>+</sup>; the difference should be less than 0.5μV due to the 140dB minimum CMRR of the LTC2483.

## EXPERIMENTS

### Bipolar Symmetry

To demonstrate the symmetry of the ADCs transfer function, connect a stable, low noise, floating voltage source (with a voltage less than  $V_{REF/2}$ ) from  $IN^+$  to  $IN^-$  and note the indicated voltage. Reverse the polarity; the indicated voltage will typically be within one LSB of the first reading multiplied by  $-1$ .

One convenient voltage source for this experiment is a single alkaline battery. While a battery has fairly low noise, it is sensitive to temperature drift. It is best to use a large (D-size) battery that is insulated from air currents. A better source is a battery powered series reference such as the LT1790. This part is available with output voltages of 1.25V, 2.048V, 2.5V, 3V, 3.3V, 4.096V and 5V.

### Input Normal Mode Rejection

The LTC2483's SINC4 digital filter is trimmed to reject 50Hz and 60Hz line noise when operated with the internal conversion clock. To measure input normal mode rejection, connect  $IN^-$  to a 2.5V source such as an LT1790-2.5 reference or 1k – 1k divider from the onboard 5V reference to ground. Apply a 10Hz, 2V peak-to-peak sine wave to  $IN^+$  through a 1 $\mu$ F capacitor. No DC bias is required because the 2M to 3M input impedance of the LTC2483 tends to self-bias the input to mid-reference (see data sheet applications information for details.)

Start taking data. The input noise will be quite large, and the graph of output vs. time should show large variations.

Next, slowly increase the frequency to 55Hz. The noise should be almost undetectable in the graph. Note that the indicated noise in ppm may still be above that of the data sheet specification because  $IN^+$  is not connected to a DC source.

## PARTS LIST

ITEM	QTY	REFERENCE	PART DESCRIPTION	MANUFACTURER/PART NUMBER
1	2	C1, C2	CAP., X7R, 0.1 $\mu$ F, 16V, 20%, 0402	TDK, C1005X7R1C104M
2	1	C3	CAP., X5R, 4.7 $\mu$ F, 6.3V, 20%, 0603	TDK, C1608X5R0J475M
3	1	C4	CAP., X5R, 1 $\mu$ F, 6.3V, 20%, 0402	TDK, C1005X5R0J105M
4	1	C5	CAP., X7R, 0.01 $\mu$ F, 25V, 10%, 0402	AVX, 04023C103KAT1A
5	9	E1 to E9	TESTPOINT, TURRET, .064"	MILL-MAX, 2308-2
6	4	JP1, JP2, JP3, JP4	JMP, 3-PIN, 1 ROW .079CC	SAMTEC, TMM-103-02-L-S
7	4	SHUNTS FOR JP1 to JP4 PIN 1 & 2	SHUNT, .079" CENTER	SAMTEC, 2SN-BK-G
8	1	J1	HEADER, 2 $\times$ 7 PIN, 0.079CC	MOLEX, 87831-1420
9	3	R1, R2, R3	RES., CHIP 4.99k, 1/16W, 1%, 0402	VISHAY, CRCW04024991FM
10	1	U1	I.C., LTC2483CDD, DFN10DD	LINEAR TECH., LTC2483CDD
11	1	U2	I.C., LT1790ACS6-5, SOT23-6	LINEAR TECH., LT1790ACS6-5
12	1	U3	I.C., 24LC025, TSSOP8	MICROCHIP, 24LC025-I/ST

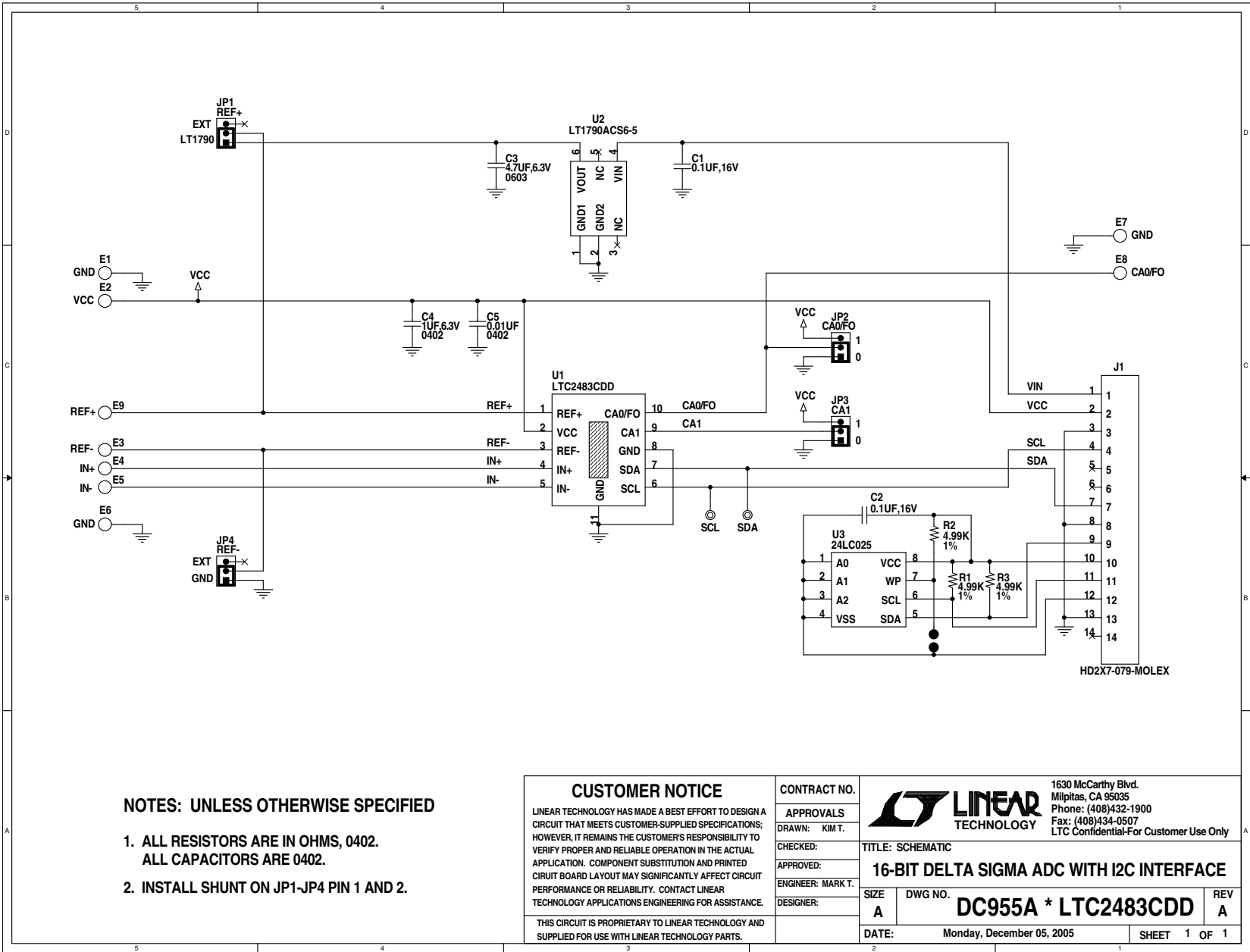

**NOTES: UNLESS OTHERWISE SPECIFIED**

1. ALL RESISTORS ARE IN OHMS, 0402.
- ALL CAPACITORS ARE 0402.
2. INSTALL SHUNT ON JP1-JP4 PIN 1 AND 2.

**CUSTOMER NOTICE**

LINEAR TECHNOLOGY HAS MADE A BEST EFFORT TO DESIGN A CIRCUIT THAT MEETS CUSTOMER-SUPPLIED SPECIFICATIONS; HOWEVER, IT REMAINS THE CUSTOMER'S RESPONSIBILITY TO VERIFY PROPER AND RELIABLE OPERATION IN THE ACTUAL APPLICATION. COMPONENT SUBSTITUTION AND PRINTED CIRCUIT BOARD LAYOUT MAY SIGNIFICANTLY AFFECT CIRCUIT PERFORMANCE OR RELIABILITY. CONTACT LINEAR TECHNOLOGY APPLICATIONS ENGINEERING FOR ASSISTANCE.

THIS CIRCUIT IS PROPRIETARY TO LINEAR TECHNOLOGY AND SUPPLIED FOR USE WITH LINEAR TECHNOLOGY PARTS.

CONTRACT NO.	
APPROVALS	
DRAWN: KIM T.	
CHECKED:	
APPROVED:	
ENGINEER: MARK T.	
DESIGNER:	

		1630 McCarthy Blvd. Milpitas, CA 95035 Phone: (408)432-1900 Fax: (408)434-0507 LTC Confidential-For Customer Use Only	
		TITLE: SCHEMATIC <b>16-BIT DELTA SIGMA ADC WITH I2C INTERFACE</b>	
SIZE <b>A</b>	DWG NO. <b>DC955A * LTC2483CDD</b>	REV <b>A</b>	
DATE:	Monday, December 05, 2005	SHEET	1 OF 1

# DEMO MANUAL DC955A

---

## DEMONSTRATION BOARD IMPORTANT NOTICE

Linear Technology Corporation (LTC) provides the enclosed product(s) under the following **AS IS** conditions:

This demonstration board (DEMO BOARD) kit being sold or provided by Linear Technology is intended for use for **ENGINEERING DEVELOPMENT OR EVALUATION PURPOSES ONLY** and is not provided by LTC for commercial use. As such, the DEMO BOARD herein may not be complete in terms of required design-, marketing-, and/or manufacturing-related protective considerations, including but not limited to product safety measures typically found in finished commercial goods. As a prototype, this product does not fall within the scope of the European Union directive on electromagnetic compatibility and therefore may or may not meet the technical requirements of the directive, or other regulations.

If this evaluation kit does not meet the specifications recited in the DEMO BOARD manual the kit may be returned within 30 days from the date of delivery for a full refund. **THE FOREGOING WARRANTY IS THE EXCLUSIVE WARRANTY MADE BY THE SELLER TO BUYER AND IS IN LIEU OF ALL OTHER WARRANTIES, EXPRESSED, IMPLIED, OR STATUTORY, INCLUDING ANY WARRANTY OF MERCHANTABILITY OR FITNESS FOR ANY PARTICULAR PURPOSE. EXCEPT TO THE EXTENT OF THIS INDEMNITY, NEITHER PARTY SHALL BE LIABLE TO THE OTHER FOR ANY INDIRECT, SPECIAL, INCIDENTAL, OR CONSEQUENTIAL DAMAGES.**

The user assumes all responsibility and liability for proper and safe handling of the goods. Further, the user releases LTC from all claims arising from the handling or use of the goods. Due to the open construction of the product, it is the user's responsibility to take any and all appropriate precautions with regard to electrostatic discharge. Also be aware that the products herein may not be regulatory compliant or agency certified (FCC, UL, CE, etc.).

No License is granted under any patent right or other intellectual property whatsoever. **LTC assumes no liability for applications assistance, customer product design, software performance, or infringement of patents or any other intellectual property rights of any kind.**

LTC currently services a variety of customers for products around the world, and therefore this transaction **is not exclusive**.

**Please read the DEMO BOARD manual prior to handling the product.** Persons handling this product must have electronics training and observe good laboratory practice standards. **Common sense is encouraged.**

This notice contains important safety information about temperatures and voltages. For further safety concerns, please contact a LTC application engineer.

Mailing Address:

Linear Technology  
1630 McCarthy Blvd.  
Milpitas, CA 95035

Copyright © 2004, Linear Technology Corporation