



Chipsmall Limited consists of a professional team with an average of over 10 year of expertise in the distribution of electronic components. Based in Hongkong, we have already established firm and mutual-benefit business relationships with customers from,Europe,America and south Asia,supplying obsolete and hard-to-find components to meet their specific needs.

With the principle of “Quality Parts,Customers Priority,Honest Operation,and Considerate Service”,our business mainly focus on the distribution of electronic components. Line cards we deal with include Microchip,ALPS,ROHM,Xilinx,Pulse,ON,Everlight and Freescale. Main products comprise IC,Modules,Potentiometer,IC Socket,Relay,Connector.Our parts cover such applications as commercial,industrial, and automotives areas.

We are looking forward to setting up business relationship with you and hope to provide you with the best service and solution. Let us make a better world for our industry!



Contact us

Tel: +86-755-8981 8866 Fax: +86-755-8427 6832

Email & Skype: info@chipsmall.com Web: www.chipsmall.com

Address: A1208, Overseas Decoration Building, #122 Zhenhua RD., Futian, Shenzhen, China



LTC2442

24-Bit High Speed 4-Channel $\Delta\Sigma$ ADC with Integrated Amplifier

DESCRIPTION

The **LTC[®]2442** is a 2-/4-channel, high speed, 24-bit $\Delta\Sigma$ ADC with ten selectable speed/resolution modes from 6.9Hz/200nV_{RMS} to 3.5kHz/25 μ V_{RMS}. Key DC specifications include 4ppm maximum INL, 5 μ V offset, 10ppm full-scale error and 20nV/°C offset drift. In the 6.9Hz/200nV_{RMS} mode, an input normal mode rejection of 50Hz and 60Hz noise is better than 87dB. The accuracy (offset, full-scale, linearity, drift) and power dissipation are independent of the speed selected. The LTC2442 incorporates rail-to-rail buffer amplifiers for true high impedance inputs.

DC979A is a member of Linear Technology's QuikEval™ family of demonstration boards. It is designed to allow

easy evaluation of the LTC2442 and may be connected directly to the target application's analog signals while using the DC590 USB serial controller board and supplied software to measure performance. The exposed ground planes allow proper grounding to prototype circuitry. After evaluating with LTC's software, the digital signals can be connected to the application's processor/controller for development of the serial interface.

Design files for this circuit board are available at <http://www.linear.com/demo>

LT, LT, LTC, LTM, Linear Technology and the Linear logo are registered trademarks and QuikEval and SoftSpan are a trademarks of Linear Technology Corporation. All other trademarks are the property of their respective owners.

BOARD PHOTO

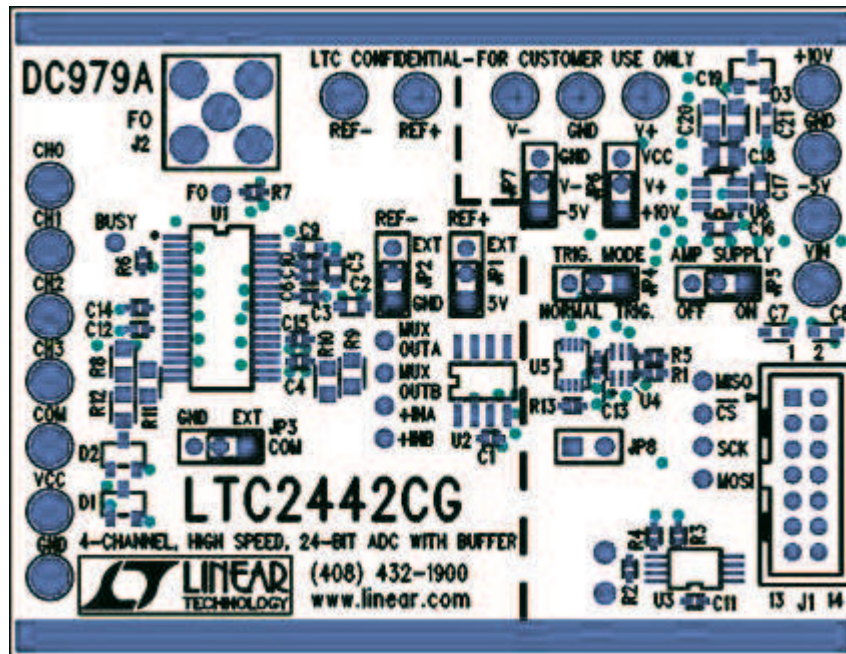

Figure 1. DC979A Demonstration Board

QUICK START PROCEDURE

1. Connect the DC979A to a DC590 USB serial controller using the supplied 14-conductor ribbon cable.
2. Connect the DC590 to the host PC with a standard USB A/B cable.
3. Run the QuikEval evaluation software supplied with the DC590 or download it from www.linear.com/software. The correct program will be loaded automatically.
4. Click the COLLECT button to start reading the input voltage.
5. Click the slider at the bottom of the strip chart display to change the oversample ratio (OSR) which will in turn change the data output rate.

Tools are available for logging data, changing reference voltage, changing the number of points in the strip chart and histogram, and changing the number of points averaged for the DVM display.

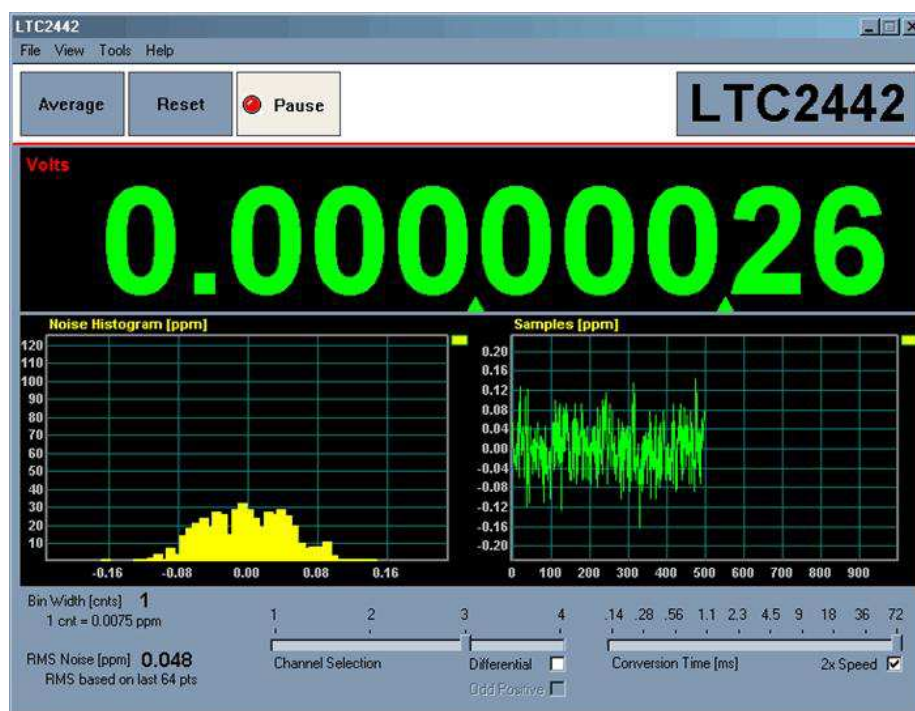

Figure 2. QuikEval Software

HARDWARE SETUP

JUMPERS

JP1, JP2: Select the source for REF⁺ and REF⁻, respectively. REF⁺ can be 5.00V from the onboard LT[®]1236 reference (default) or supplied externally. REF⁻ can be ground (0V, default) or supplied externally.

JP3: Select source for analog COM input, either tied to ground or supplied externally to the COM turret post.

JP6, JP7: Select the positive and negative supply voltages for the onboard amplifier. Supplies can be V_{CC} and GND or +10 and -5V from the onboard LTC1983 charge pump. To use an external power supply, REMOVE JP6 and JP7 and connect the external supply to the V⁺, GND, and V⁻ turrets.

JP4: Trigger mode, either normal (default) or externally triggered (TRIG).

HARDWARE SETUP

JP5: Enable/disable the LTC1983 charge pump power supply for onboard amplifier. See JP6, JP7 description.

JP8: Trigger Input Signal. Pin 1 is a 5V logic input, Pin 2 is ground. When triggered mode is selected on JP4, a rising edge starts a new conversion. Note that since a conversion cannot be terminated once started, this signal can only be used to slow down the conversion rate.

CONNECTION TO DC590 SERIAL CONTROLLER

J1 is the power and digital interface connector. Connect to the DC590 serial controller with the supplied 14-conductor ribbon cable.

ANALOG CONNECTIONS

Analog signal connections are made via the row of turret posts along the edge of the board. Also, if you are connecting the board to an existing circuit, the exposed ground planes along the edges of the board may be used to form a solid connection between grounds.

GND: Ground turrets are connected directly to the internal analog ground plane.

VCC: This is the supply for the ADC. Do not draw any power from this point. External power may be applied to this point after disabling the switching supply on the DC590. If the DC590 serial controller is being used, the voltage must be regulated 5V only, as the isolation circuitry will also be powered from this supply. See the DC590 Quick Start guide for details.

REF⁺, REF⁻: These turrets are connected to the LTC2442 REF⁺ and REF⁻ pins. If the onboard reference is being used, the reference voltage may be monitored from this point. An external reference may be connected to these terminals if JP1 and JP2 are configured for external reference.

Note: The REF⁺ and REF⁻ terminals are decoupled to ground with 0.01 μ F and 4.7 μ F capacitors in parallel. Thus, any source connected to these terminals must be able to drive a capacitive load and have very low impedance at DC. Examples are series references that require an output capacitor and C-load stable op amps, such as the LT1219 and LT1368/

CH0-CH3: These are the differential inputs to the LTC2442. They may be configured either as single-ended inputs with respect to the COM pin, or adjacent pairs may be configured as differential inputs (CH0-CH1, CH2-CH3.)

EXPERIMENTS

INPUT NOISE

Solder a short wire from CH0 to CH1. Ensure that the buffer amplifiers are in their active region of operation by either biasing the inputs to mid-supply with a 10k Ω to 10k Ω divider when the buffer amplifier is powered from V_{CC} and ground, or tie the inputs to ground and select +10 and -5V for V⁺ and V⁻.

Set the demo software to OSR32768 (6.8 samples per second) and check the 2X box. Noise should be approximately 0.04ppm of V_{REF} (200nV.) Next, select different oversample ratios. Measured noise for each oversample ratio should be close to the values given in the LTC2442 data sheet.

COMMON MODE REJECTION

Tie the two inputs (still connected together from the previous experiment) to ground through a short wire and note the indicated voltage. Tie the inputs to REF⁺; the difference should be less than 5 μ V due to the 120dB CMRR of the LTC2442.

Select +10 and -5V for V⁺ and V⁻ for this experiment. If the common mode voltage is limited to GND + 0.25V to V_{CC} - 0.25V, this test may be performed with the amplifier supplies set to ground and V_{CC}.

DEMO MANUAL DC979A

EXPERIMENTS

INPUT NORMAL MODE REJECTION

The LTC2442's SINC4 digital filter is trimmed to strongly reject both 50Hz and 60Hz line noise when operated with the internal conversion clock and oversample ratio 32768 (6.8 samples per second.) To measure input normal mode rejection, connect COM to a 2.5V source such as an LT1790-2.5 reference or a power supply. Connect any other input (CH0-CH3) to the same supply through a 10k resistor. Apply a 10Hz, 2V peak-to-peak sine wave to the input through a 1 μ F capacitor.

Select OSR32768 (6.8 samples per second) and 2X mode in the demo software and start taking data. The input noise will be quite large, and the graph of output vs time should show large variations.

Next, slowly increase the frequency to 55Hz. The noise should be almost undetectable in the graph.

Change the OSR to 16384 (13.75 samples per second) the noise will increase substantially, as the first notch at this OSR is at 110Hz. Increase the signal generator frequency to 110Hz, the noise will drop again.

PARTS LIST

ITEM	QTY	REFERENCE	PART DESCRIPTION	MANUFACTURER/PART NUMBER
DC979A Required Circuit Components				
1	7	C1, C4, C11-C15	CAP., X7R, 0.1 μ F, 16V, 20%, 0402	TDK, C1005X7R1C104M
2	8	C2, C5, C7, C8, C9, C16, C17, C21	CAP., X5R, 4.7 μ F, 10V, 20%, 0603	TDK, C1608X5R0J475M
3	3	C3, C6, C10	CAP., X7R, 0.01 μ F, 25V, 10%, 0402	AVX, 04023C103KAT1A
4	3	C18, C19, C20	CAP., X5R, 2.2 μ F, 10V, 20%, 0805	TDK, C2012X5R1A225M
5	3	D1, D2, D3	DIODE, SCHOTTKY, SOT23	DIODE INC., BAT54S
6	16	E1-E16	TESTPOINT, TURRET, 0.064"	MILL-MAX, 2308-2
7	7	JP1-JP7	JMP, 3-PIN, 1 ROW, 0.079"	SAMTEC, TMM-103-02-L-S
8	7	FOR JP1-JP7, PIN 1 AND PIN 2	SHUNT, 0.079" CENTER	SAMTEC, 2SN-BK-G
9	0	JP8	JMP, 2-PIN, 1 ROW, 0.100"	COMM CON., 3801S-02G2
10	1	J1	HEADER, 2x7 PIN, 0.079"	MOLEX, 87831-1420
11	0	J2	CONN, 5-PIN, GOLD, STRAIGHT	CONNEX, 132134
12	0	R1	RES., 0402	OPT
13	3	R2, R3, R4	RES., CHIP, 4.99k, 1/16W, 1%, 0402	AAC, CR05-4991FM
14	1	R5	RES., CHIP, 100, 1/16W, 5%, 0402	VISHAY, CRCW0402101J
15	2	R6, R13	RES., CHIP, 10k, 1/16W, 5%, 0402	AAC, CR05-103JM
16	1	R7	RES., CHIP, 51, 1/16W, 5%, 0402	AAC, CR05-510JM
17	4	R8, R9, R10, R12	RES., CHIP, 0, 1/16W, 5%, 0805	AAC, CJ10-000M
18	0	R11	RES., CHIP, 0, 1/16W, 5%, 0805	OPT
19	1	U1	I.C., LTC2442CG, SSOP36G	LINEAR TECHNOLOGY, LTC2442CG
20	1	U2	I.C., LT1236ACS8-5, S08	LINEAR TECHNOLOGY, LT1236ACS8-5
21	1	U3	I.C., 24LC025, TSSOP8	MICROCHIP, 24LC025-I/ST
22	1	U4	IC, NON-INVERTING MULTIPLEXER, SC70	FAIRCHILD, NC7SZ157P6X
23	1	U5	IC, SINGLE D, FLIP-FLOP, US8	ON SEMI., NL17SZ74US
24	1	U6	I.C., LTC1983ES6-5, SOT23-6	LINEAR TECHNOLOGY, LTC1983ES6-5

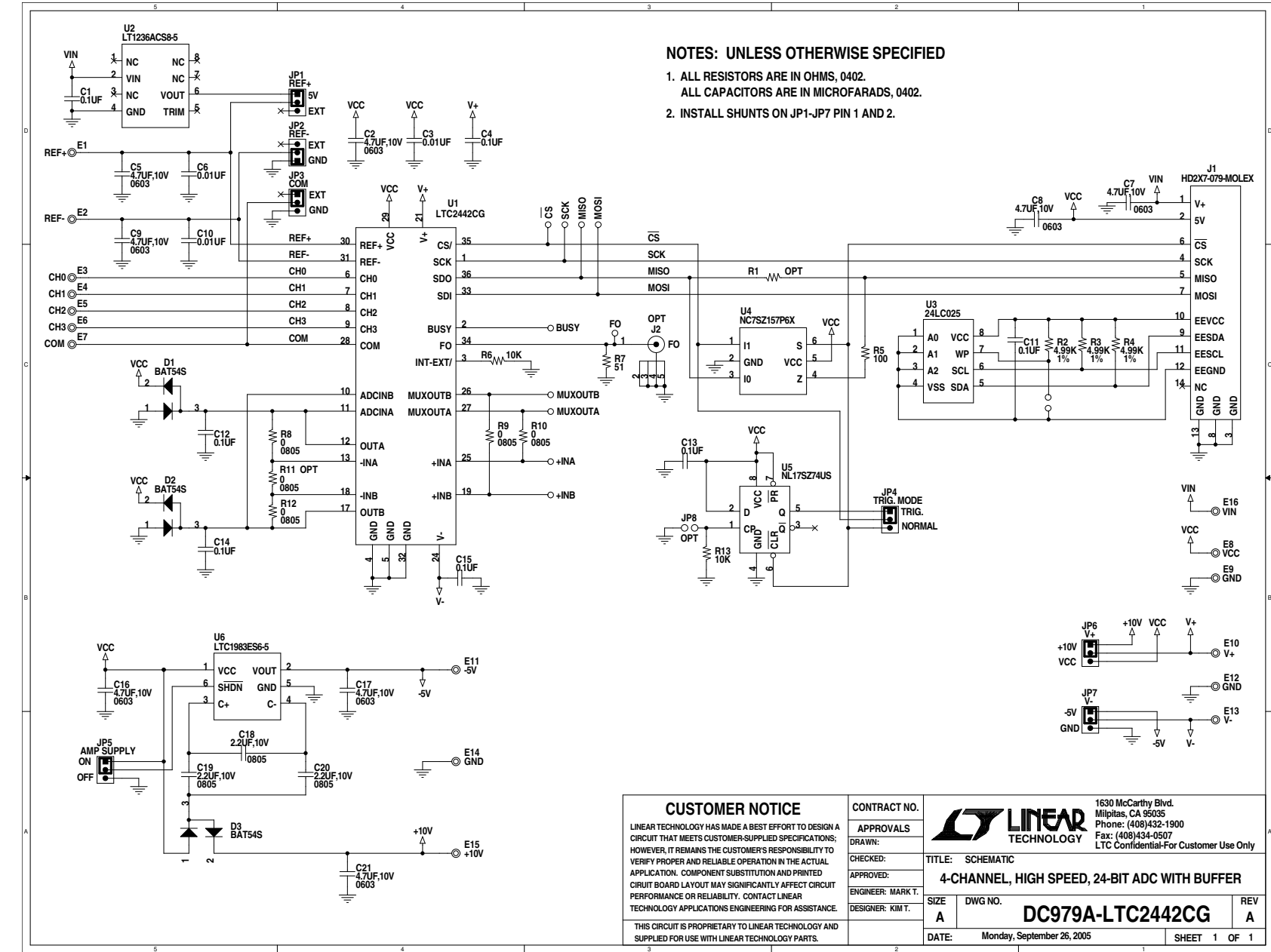

<p>CUSTOMER NOTICE</p> <p>LINEAR TECHNOLOGY HAS MADE A BEST EFFORT TO DESIGN A CIRCUIT THAT MEETS CUSTOMER-SUPPLIED SPECIFICATIONS; HOWEVER, IT REMAINS THE CUSTOMER'S RESPONSIBILITY TO VERIFY PROPER AND RELIABLE OPERATION IN THE ACTUAL APPLICATION. COMPONENT SUBSTITUTION MAY AFFECT CIRCUIT BOARD LAYOUT AND PERFORMANCE OR RELIABILITY. CONTACT LINEAR TECHNOLOGY APPLICATIONS ENGINEERING FOR ASSISTANCE.</p> <p>THIS CIRCUIT IS PROPRIETARY TO LINEAR TECHNOLOGY AND SUPPLIED FOR USE WITH LINEAR TECHNOLOGY PARTS.</p>	<p>CONTRACT NO.</p>	<p>1630 McCarthy Blvd. Milpitas, CA 95035 Phone: (408)432-1900 Fax: (408)434-0507 LTC Confidential-For Customer Use Only</p>
	<p>APPROVALS</p>	
	<p>DRAWN:</p>	
	<p>CHECKED:</p>	
<p>APPROVED:</p>	<p>TITLE: SCHEMATIC</p>	<p>4-CHANNEL, HIGH SPEED, 24-BIT ADC WITH BUFFER</p>
<p>ENGINEER: MARK T.</p>	<p>SIZE DWG NO.</p>	
<p>DESIGNER: KIM T.</p>	<p>DC979A-LTC2442CG</p>	
<p>DATE: Monday, September 26, 2005</p>	<p>SHEET 1 OF 1</p>	

Figure 3. DC979A 4-Channel, High Speed, 24-Bit ADC with Buffer

DEMO MANUAL DC979A

DEMONSTRATION BOARD IMPORTANT NOTICE

Linear Technology Corporation (LTC) provides the enclosed product(s) under the following **AS IS** conditions:

This demonstration board (DEMO BOARD) kit being sold or provided by Linear Technology is intended for use for **ENGINEERING DEVELOPMENT OR EVALUATION PURPOSES ONLY** and is not provided by LTC for commercial use. As such, the DEMO BOARD herein may not be complete in terms of required design-, marketing-, and/or manufacturing-related protective considerations, including but not limited to product safety measures typically found in finished commercial goods. As a prototype, this product does not fall within the scope of the European Union directive on electromagnetic compatibility and therefore may or may not meet the technical requirements of the directive, or other regulations.

If this evaluation kit does not meet the specifications recited in the DEMO BOARD manual the kit may be returned within 30 days from the date of delivery for a full refund. **THE FOREGOING WARRANTY IS THE EXCLUSIVE WARRANTY MADE BY THE SELLER TO BUYER AND IS IN LIEU OF ALL OTHER WARRANTIES, EXPRESSED, IMPLIED, OR STATUTORY, INCLUDING ANY WARRANTY OF MERCHANTABILITY OR FITNESS FOR ANY PARTICULAR PURPOSE. EXCEPT TO THE EXTENT OF THIS INDEMNITY, NEITHER PARTY SHALL BE LIABLE TO THE OTHER FOR ANY INDIRECT, SPECIAL, INCIDENTAL, OR CONSEQUENTIAL DAMAGES.**

The user assumes all responsibility and liability for proper and safe handling of the goods. Further, the user releases LTC from all claims arising from the handling or use of the goods. Due to the open construction of the product, it is the user's responsibility to take any and all appropriate precautions with regard to electrostatic discharge. Also be aware that the products herein may not be regulatory compliant or agency certified (FCC, UL, CE, etc.).

No License is granted under any patent right or other intellectual property whatsoever. **LTC assumes no liability for applications assistance, customer product design, software performance, or infringement of patents or any other intellectual property rights of any kind.**

LTC currently services a variety of customers for products around the world, and therefore this transaction **is not exclusive**.

Please read the DEMO BOARD manual prior to handling the product. Persons handling this product must have electronics training and observe good laboratory practice standards. **Common sense is encouraged.**

This notice contains important safety information about temperatures and voltages. For further safety concerns, please contact a LTC application engineer.

Mailing Address:

Linear Technology
1630 McCarthy Blvd.
Milpitas, CA 95035

Copyright © 2004, Linear Technology Corporation