



Chipsmall Limited consists of a professional team with an average of over 10 year of expertise in the distribution of electronic components. Based in Hongkong, we have already established firm and mutual-benefit business relationships with customers from,Europe,America and south Asia,supplying obsolete and hard-to-find components to meet their specific needs.

With the principle of “Quality Parts,Customers Priority,Honest Operation,and Considerate Service”,our business mainly focus on the distribution of electronic components. Line cards we deal with include Microchip,ALPS,ROHM,Xilinx,Pulse,ON,Everlight and Freescale. Main products comprise IC,Modules,Potentiometer,IC Socket,Relay,Connector.Our parts cover such applications as commercial,industrial, and automotives areas.

We are looking forward to setting up business relationship with you and hope to provide you with the best service and solution. Let us make a better world for our industry!



Contact us

Tel: +86-755-8981 8866 Fax: +86-755-8427 6832

Email & Skype: info@chipsmall.com Web: www.chipsmall.com

Address: A1208, Overseas Decoration Building, #122 Zhenhua RD., Futian, Shenzhen, China



DO NOT SCALE FROM THIS PRINT

DESIGNED & DIMENSIONED IN MILLIMETERS [INCHES]

No OF PORTS _____
 -01: SINGLE PORT
 -02: DUAL PORT (ONLY AVAILABLE ON TYPE A)
 TYPE
 -A: USB TYPE A
 -B: USB TYP B
 OPTION
 -01: W/STRAP

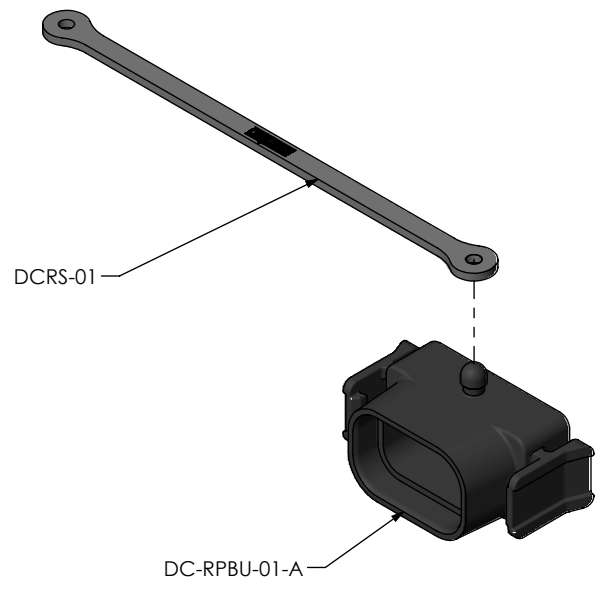
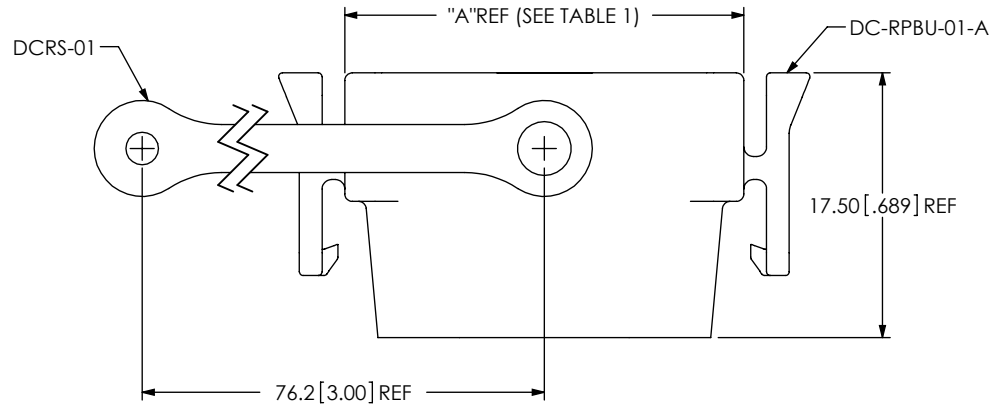

No OF PORTS	"A"
-01	26.40 [1.039]
-02	48.05 [1.892]

FIG. 1
 DCA-RPBU-01-01-A SHOWN
 (FOR RPBU-XX-X-A-XX-XX PANEL ONLY)

- NOTES:
1. Ⓢ REPRESENTS A CRITICAL DIMENSION.
 2. COMPONENTS OF SUB-ASSEMBLY TO BE INSPECTED USING COMPONENT PRINTS.
 3. MINIMUM RETENTION: 4.4N [1.0 LB].
 4. PARTS TO BE BULK PACKAGED.

UNLESS OTHERWISE SPECIFIED, DIMENSIONS ARE IN MILLIMETERS. TOLERANCES ARE: DECIMALS ANGLES X.X: ±0.3 [.01] 2° X.XX: ±0.13 [.005] X.XXX: ±0.051 [.0020]	PROPRIETARY NOTE THIS DOCUMENT CONTAINS INFORMATION CONFIDENTIAL AND PROPRIETARY TO SAMTEC, INC. AND SHALL NOT BE REPRODUCED OR TRANSFERRED TO OTHER DOCUMENTS OR DISCLOSED TO OTHERS OR USED FOR ANY PURPOSE OTHER THAN THAT WHICH IT WAS OBTAINED WITHOUT THE EXPRESSED WRITTEN CONSENT OF SAMTEC, INC.	 520 PARK EAST BLVD, NEW ALBANY, IN 47150 PHONE: 812-944-6733 FAX: 812-948-5047 e-Mail: info@SAMTEC.com code 55322	
		DESCRIPTION: DUST CAP FOR RPBU	
MATERIAL: DO NOT SCALE DRAWING SHEET SCALE: 2:1 DUST CAP: PA66 STRAP: RUBBER		DWG. NO. DCA-RPBU-XX-01-X	
F:\DWG\MISC\MKTG\DCA-RPBU-XX-01-X-MKT.SLDDRW		BY: T NEWTON 08/25/2010 SHEET 1 OF 2	

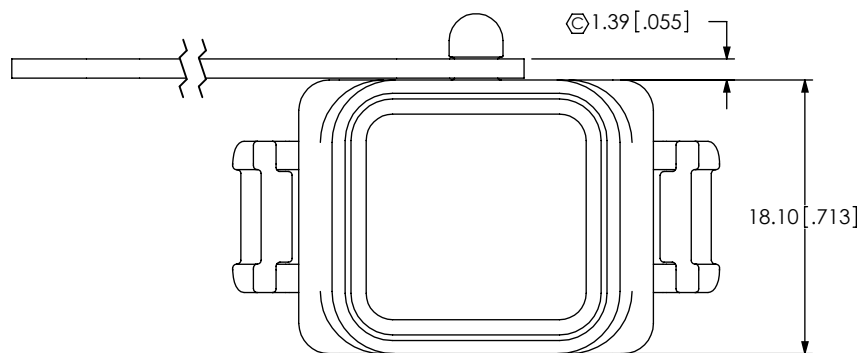
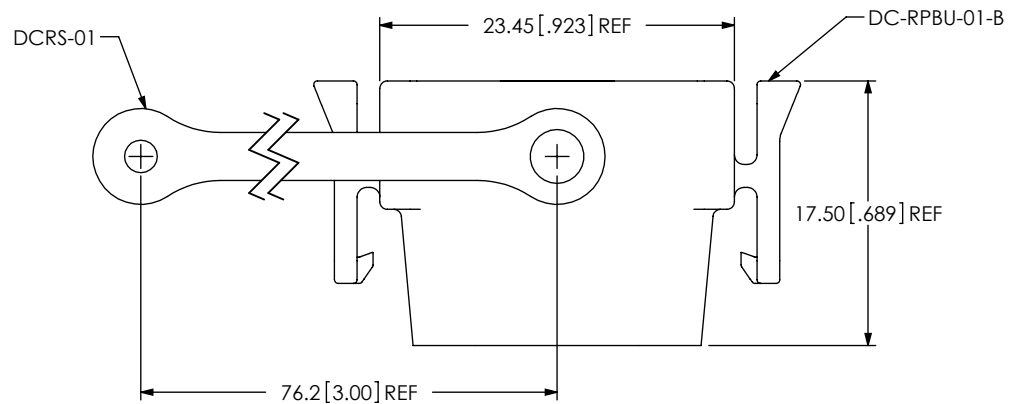
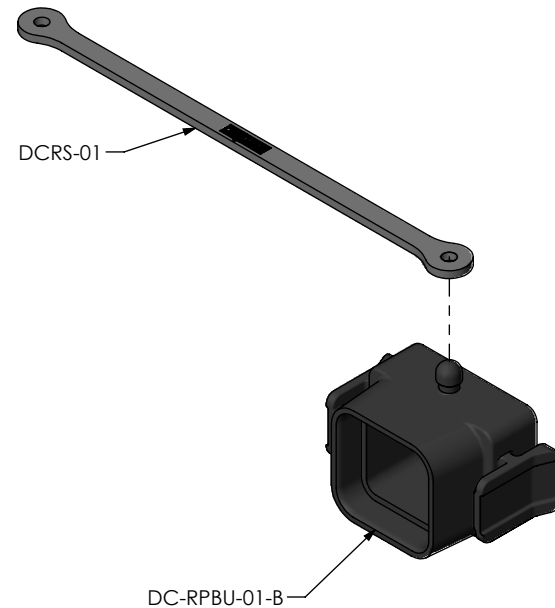



FIG. 2
DCA-RPBU-0T-0T-B SHOWN
(FOR RPBU-01-X-B-XX-XX PANEL ONLY)



<p>PROPRIETARY NOTE THIS DOCUMENT CONTAINS INFORMATION CONFIDENTIAL AND PROPRIETARY TO SAMTEC, INC. AND SHALL NOT BE REPRODUCED OR TRANSFERRED TO OTHER DOCUMENTS OR DISCLOSED TO OTHERS OR USED FOR ANY PURPOSE OTHER THAN THAT WHICH IT WAS OBTAINED WITHOUT THE EXPRESSED WRITTEN CONSENT OF SAMTEC, INC.</p> <p>DO NOT SCALE DRAWING</p> <p>SHEET SCALE: 2:1</p>		
	<p>520 PARK EAST BLVD, NEW ALBANY, IN 47150 PHONE: 812-944-6733 FAX: 812-948-5047 e-Mail info@SAMTEC.com code 55322</p>	
	<p>DESCRIPTION: DUST CAP FOR RPBU</p>	
	<p>DWG. NO. DCA-RPBU-XX-01-X</p>	
<p>BY: T NEWTON 08/25/2010</p>		<p>SHEET 2 OF 2</p>