



Chipsmall Limited consists of a professional team with an average of over 10 year of expertise in the distribution of electronic components. Based in Hongkong, we have already established firm and mutual-benefit business relationships with customers from,Europe,America and south Asia,supplying obsolete and hard-to-find components to meet their specific needs.

With the principle of “Quality Parts,Customers Priority,Honest Operation,and Considerate Service”,our business mainly focus on the distribution of electronic components. Line cards we deal with include Microchip,ALPS,ROHM,Xilinx,Pulse,ON,Everlight and Freescale. Main products comprise IC,Modules,Potentiometer,IC Socket,Relay,Connector.Our parts cover such applications as commercial,industrial, and automotives areas.

We are looking forward to setting up business relationship with you and hope to provide you with the best service and solution. Let us make a better world for our industry!



Contact us

Tel: +86-755-8981 8866 Fax: +86-755-8427 6832

Email & Skype: info@chipsmall.com Web: www.chipsmall.com

Address: A1208, Overseas Decoration Building, #122 Zhenhua RD., Futian, Shenzhen, China



Full Motion Universal Tablet and Phone Desk Clamp

MODEL NUMBER: **DDR0310SC**

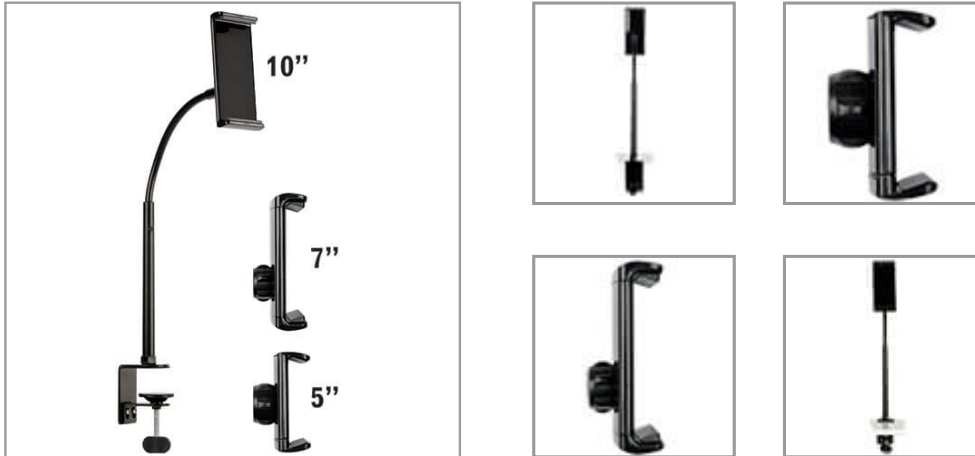

Mounts your tablet or smartphone off the surface of your desk, table or workstation to free up valuable space. Ideal for home or office use.

Description

The DDR0310SC Full Motion Universal Tablet and Phone Desk Clamp attaches to your desk, table or workstation, allowing you to mount your tablet or smartphone above it and free up valuable workspace. Durable clamp attaches to most flat surfaces up to 1.7 inches thick for a firm grip. Flexible tube bends easily to adjust your device's angle and height to fit your environment and comfort level. Includes three separate holders that fit most smartphones and tablets from 3.5 to 10 inches. Rotates 360°, so you can view your device in portrait or landscape orientation. Easy installation in seconds with no tools necessary. Supports devices up to 2.2 pounds.

Features

Attaches to Most Desks, Tables and Workstations

- Clamps securely to most flat surfaces up to 1.7 in.
- Fits most smartphones and tablets from 3.5 to 10 in.
- Flexible tube bends easily to adjust your device to a comfortable viewing angle
- Full 360° rotation for viewing in portrait or landscape orientation

Installs in Seconds

- No tools necessary
- Includes 3 separate holders to fit devices of various sizes
- Supports up to 2.2 lb.

Specifications

Highlights

- Durable clamp attaches to most flat surfaces
- 3 separate holders fit most devices from 3.5 to 10 in.
- Rotates 360° for portrait or landscape orientation
- Supports up to 2.2 lb.

Package Includes

- DDR0310SC Full Motion Universal Tablet and Phone Desk Clamp
- Owner's manual



Tripp Lite
1111 W. 35th Street
Chicago, IL 60609 USA
Telephone: 773.869.1234
www.tripplite.com

OVERVIEW	
UPC Code	037332183620
PHYSICAL	
Mounting Location	Desktop
Shipping Dimensions (hwd / in.)	3.380 x 3.230 x 14.960
Shipping Dimensions (hwd / cm)	8.59 x 8.20 x 38.00
Shipping Weight (lbs.)	2.3000
Shipping Weight (kg)	1.04
Unit Dimensions (hwd / in.)	19.69 x 7.50 x 2.82
Unit Dimensions (hwd / cm)	50.01 x 19.05 x 7.16
Unit Weight (lbs.)	1.60
Unit Weight (kg)	0.73
Material of Construction	Steel
Color	Black
Screen Size Compatibility (in.)	3.5 - 10
Screen Size Compatibility (cm)	8.89 - 25.5
Motion	Full
Degrees of Motion	360 rotate
Maximum Weight Capacity (lbs.)	2.2
Maximum Weight Capacity (kg)	1
FEATURES & SPECIFICATIONS	
Tools Necessary	No
Cord Management	No
WARRANTY	
Product Warranty Period (Worldwide)	5-year limited warranty

© 2018 Tripp Lite. All rights reserved. All product and company names are trademarks or registered trademarks of their respective holders. Use of them does not imply any affiliation with or endorsement by them. Tripp Lite has a policy of continuous improvement. Specifications are subject to change without notice. Tripp Lite uses primary and third-party agencies to test its products for compliance with standards. See a list of Tripp Lite's testing agencies: <https://www.tripplite.com/products/product-certification-agencies>