



Chipsmall Limited consists of a professional team with an average of over 10 year of expertise in the distribution of electronic components. Based in Hongkong, we have already established firm and mutual-benefit business relationships with customers from,Europe,America and south Asia,supplying obsolete and hard-to-find components to meet their specific needs.

With the principle of "Quality Parts,Customers Priority,Honest Operation,and Considerate Service",our business mainly focus on the distribution of electronic components. Line cards we deal with include Microchip,ALPS,ROHM,Xilinx,Pulse,ON,Everlight and Freescale. Main products comprise IC,Modules,Potentiometer,IC Socket,Relay,Connector.Our parts cover such applications as commercial,industrial, and automotives areas.

We are looking forward to setting up business relationship with you and hope to provide you with the best service and solution. Let us make a better world for our industry!



## Contact us

Tel: +86-755-8981 8866 Fax: +86-755-8427 6832

Email & Skype: info@chipsmall.com Web: www.chipsmall.com

Address: A1208, Overseas Decoration Building, #122 Zhenhua RD., Futian, Shenzhen, China



Electro-magnetic door locks are the most convenient and effective way to achieve secure access control.

This lock is rated at 1200 pounds holding force with a door sensor and is supplied with a kit of fixing brackets & armature plate.

### Installation

- Select gate type from the following pages, use the instructions on each page.
- Before you start: check off the contents list to identify the parts you will use
- Also check you have the correct tools to hand



Contents - GL5601		
Item	Qty	Description
1	1	Maglock – 1200 Lbs Gate
2	4	Screw M6 x 30 Cap head hex drive
7	1	Armature plate
8	1	Armature bolt - 45mm long
9	4	Rubber bung.
10	2	Armature Insert roll pin
11	1	Sleeve nut
12	1	Sleeve nut spacer tube
13	2	Armature bolt spacing washer - steel
14	2	Armature bolt spacing washer - rubber
15	1	Allen Key – 5mm A/F
16	1	Fitting/Drilling Template
Contents - EA341		
17	1	"Z" Plate for alternative mounting – 90° Armature Mount
18	1	"Z" Plate for alternative mounting – 90° Angle plate
19	1	"L" Plate for alternative mounting
20	1	Armature bolt - 25mm long
21	9	M5 x 10mm CSK Pozi #2

This product is supplied with brackets & fixings for most door configurations

### DEGL1200 Lock

Current Draw	<b>500mA/12V DC, 250mA/24VDC</b>
Voltage Selection	see next page
Lock Status LED	<b>Red (powered) / Green (secured)</b>
Holding Force	<b>1200 Lb</b>
Operational Temp	<b>-20°C to 60°C</b>
Packed Size	<b>300 x 190 x 100mm, 6385g</b>
Lock Size ( not incl connector )	<b>202 x 62 x 40mm</b>

### Order Codes for AXS Accessories

<b>MAG LOCKS</b>	
DEL600	Door Lock 600 lbs with brackets
DEL1200	Door Lock 1200 lbs with brackets ( includes door sensor)
DEGL1200	Gate Lock 1200 lbs with brackets
<b>PSU</b>	
DEPSU03	Power Supply in Wall Box, 120V, 6A/12V o/p
<b>SWITCHES</b>	
DEEX010	Remote Exit Switch (IR)
DEEM010	Emergency Override Switch with Siren

### Select door type on following pages

FOR SINGLE HINGE	- ABOVE GATE
FOR SINGLE HINGE	- INSIDE FRAME
FOR SLIDING GATE	

### You will also need

POZI #2 AND #1 SCREWDRIVER  
5MM HEX BIT DRIVER  
THREAD LOCKING COMPOUND



### Wiring Connections

#### 12 V Operation

Pair Red + Black together, connect to +12V

Pair Green and Orange together, connect to 0 V

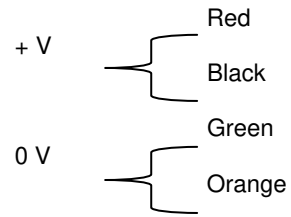

#### 24 V Operation

Pair Black + Green together

Connect Red to + 24V

Connect Orange to 0 V

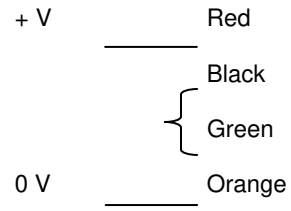

This gate lock is designed for connection to standard 1 inch threaded conduit



### Installation Above Gate

1. Check off the contents and ensure you have the tools required.
2. Use the drill template to install the lock above the gate.
3. Check the gate still closes.
4. Remove Qty 2 screws and replace with counter sink screws
5. Fit the maglock to the L bracket using 2 Security Screws Item 1C.
6. Assemble both Z plates and the Armature plate together as shown.
7. Close the door and use the Z plate to mark the gate for drilling.
8. Fit the Armature assembly to the gate.
9. Check that the Armature plate and mag lock are aligned.
10. Use rubber spacer washers ( or use alternate Z bracket fixing positions) to ensure that the Armature plate and Mag Lock to just touch.
11. Set the wiring to the correct voltage, connect, power up and test.

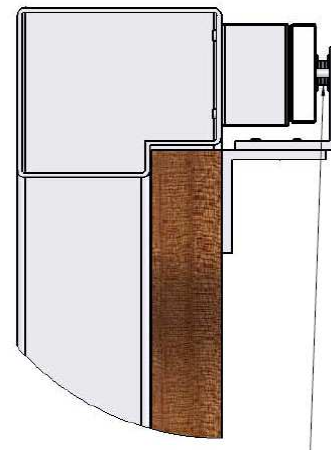

Adjust the gap between lock and armature plate by adding /removing spacer washers Items 13 & 14

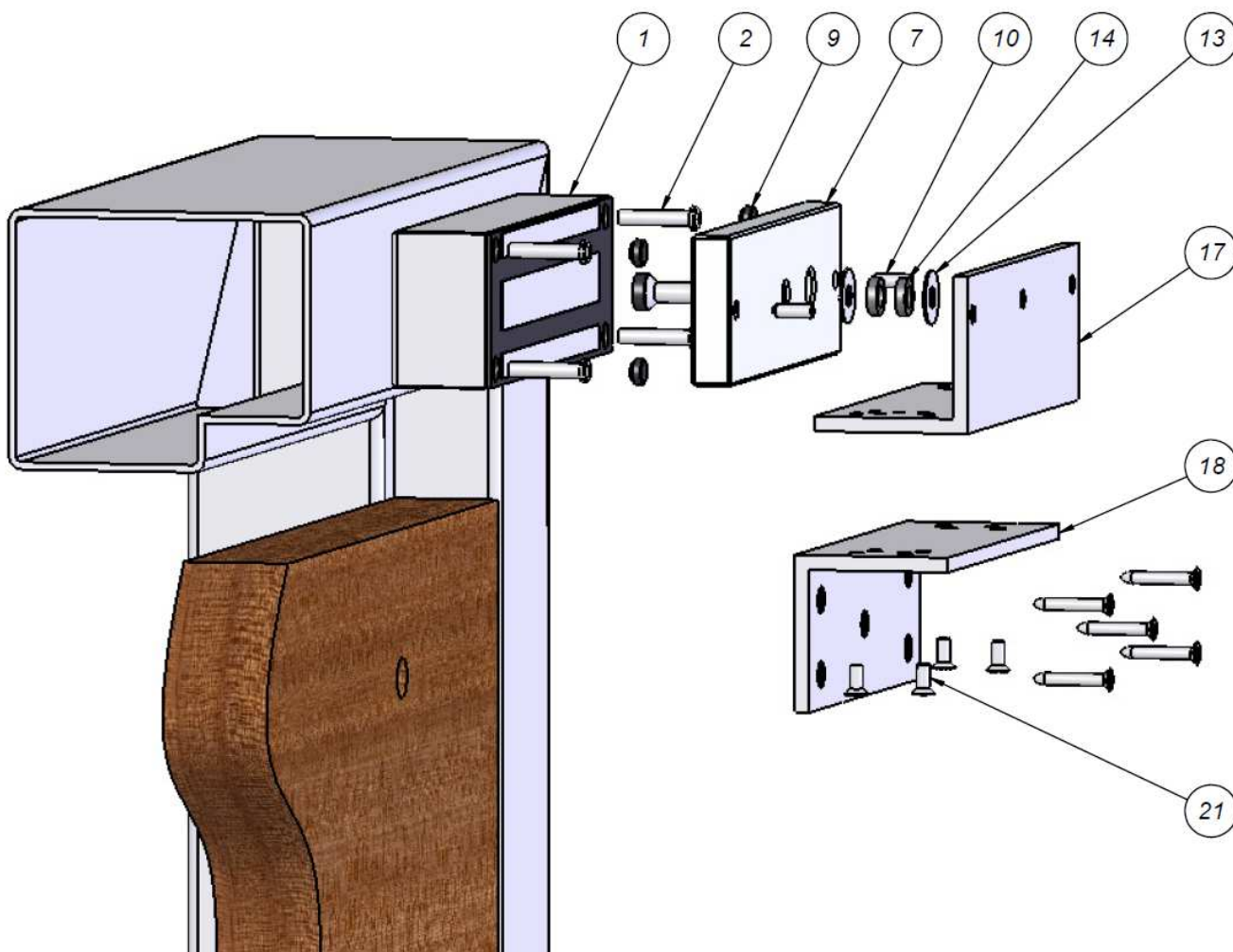

## Installation Inside Frame

1. Check off the contents and ensure you have the tools required.
2. Use the drill template to install the mounting bracket Item 1A inside the frame.
3. Drill frame for cable entry and run cable for maglock.
4. Fit the maglock to the bracket using 2 Security Screws Item 1C.
5. Close the door and use the armature to mark the gate for drilling.
6. Fit the Armature to the gate
7. Make sure the Armature and mag lock are aligned.
8. Use spacer washers to get the Armature plate and Mag Lock to just touch.
9. Set the wiring to the correct voltage, connect, power up and test.

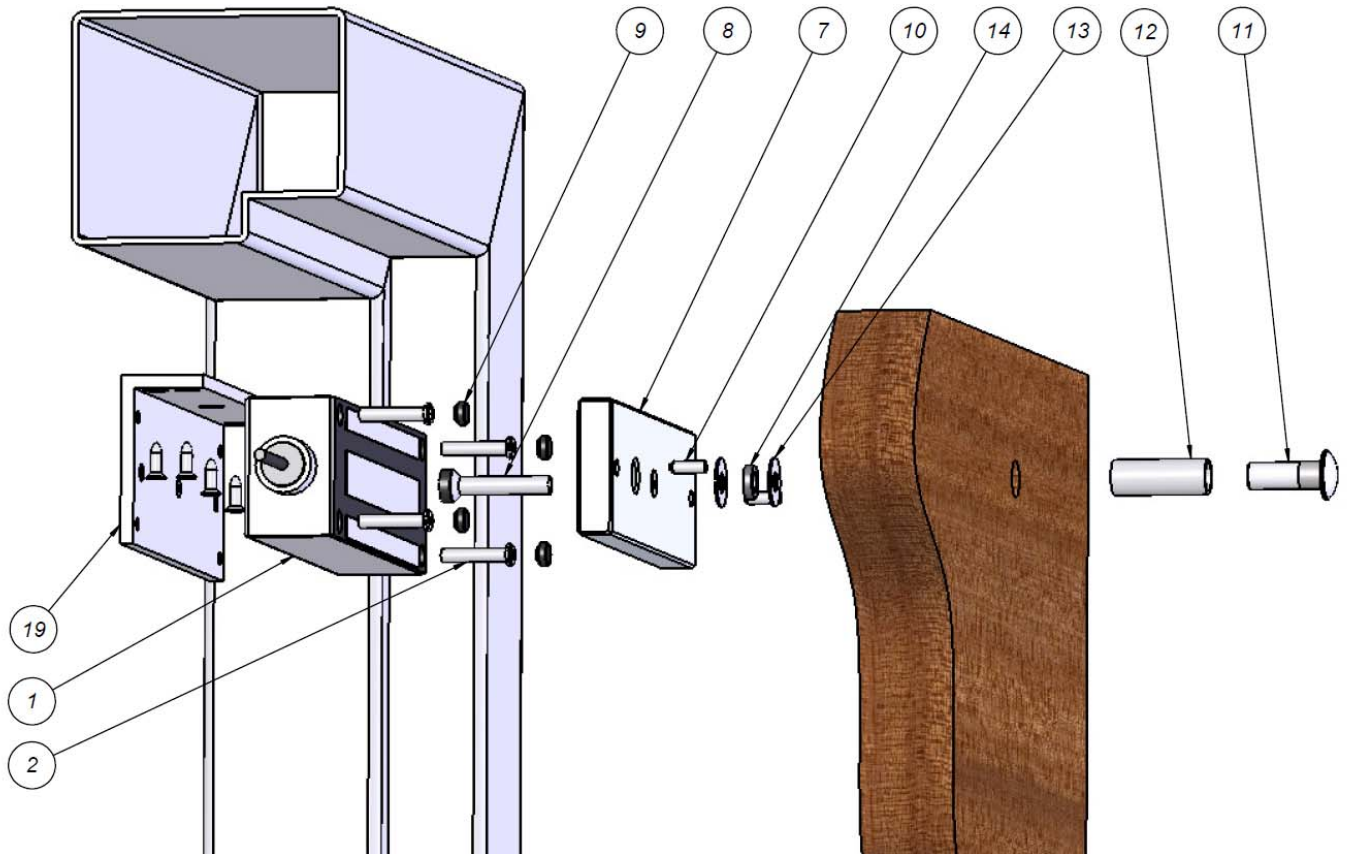
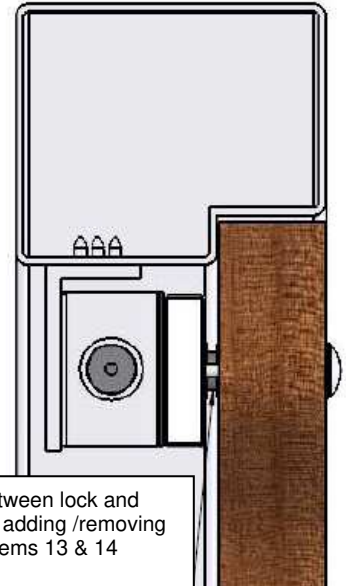

### Installation for Sliding Gate

1. Check off the contents and ensure you have the tools required.
2. Use the drill template to install the mounting bracket Item 1A to the frame.
3. Fit the maglock to the bracket using 2 Security Screws Item 1C.
4. Close the door and use the Z plate item 17 to mark the gate for drilling.
5. Fit the Z plate and Armature to the gate.
6. Make sure the Armature and mag lock are aligned.
7. Use spacer washers to get the Armature plate and Mag Lock to just touch -----
8. Set the wiring to the correct voltage, connect, power up and test.

