



Chipsmall Limited consists of a professional team with an average of over 10 year of expertise in the distribution of electronic components. Based in Hongkong, we have already established firm and mutual-benefit business relationships with customers from,Europe,America and south Asia,supplying obsolete and hard-to-find components to meet their specific needs.

With the principle of “Quality Parts,Customers Priority,Honest Operation,and Considerate Service”,our business mainly focus on the distribution of electronic components. Line cards we deal with include Microchip,ALPS,ROHM,Xilinx,Pulse,ON,Everlight and Freescale. Main products comprise IC,Modules,Potentiometer,IC Socket,Relay,Connector.Our parts cover such applications as commercial,industrial, and automotives areas.

We are looking forward to setting up business relationship with you and hope to provide you with the best service and solution. Let us make a better world for our industry!



## Contact us

Tel: +86-755-8981 8866 Fax: +86-755-8427 6832

Email & Skype: info@chipsmall.com Web: www.chipsmall.com

Address: A1208, Overseas Decoration Building, #122 Zhenhua RD., Futian, Shenzhen, China



SJ114514  
図面番号(DRAWING NO.)

版数 VER.	年月日 DATE	CN NO.	変更内容 DESCRIPTION	製図 DR.	担当 CHK.	査閲 APPD.	承認 APPD.
2	26/FEB/2014	009053	CORRECT AN ERROR (REDACTION MARK: 1)		T. SHIINA	O. TAKAGI	T. MIYASHITA
3	17/MAR/2014	009319	REVISED FORM (REDACTION MARK: 6)		T. SHIINA	O. TAKAGI	T. MIYASHITA

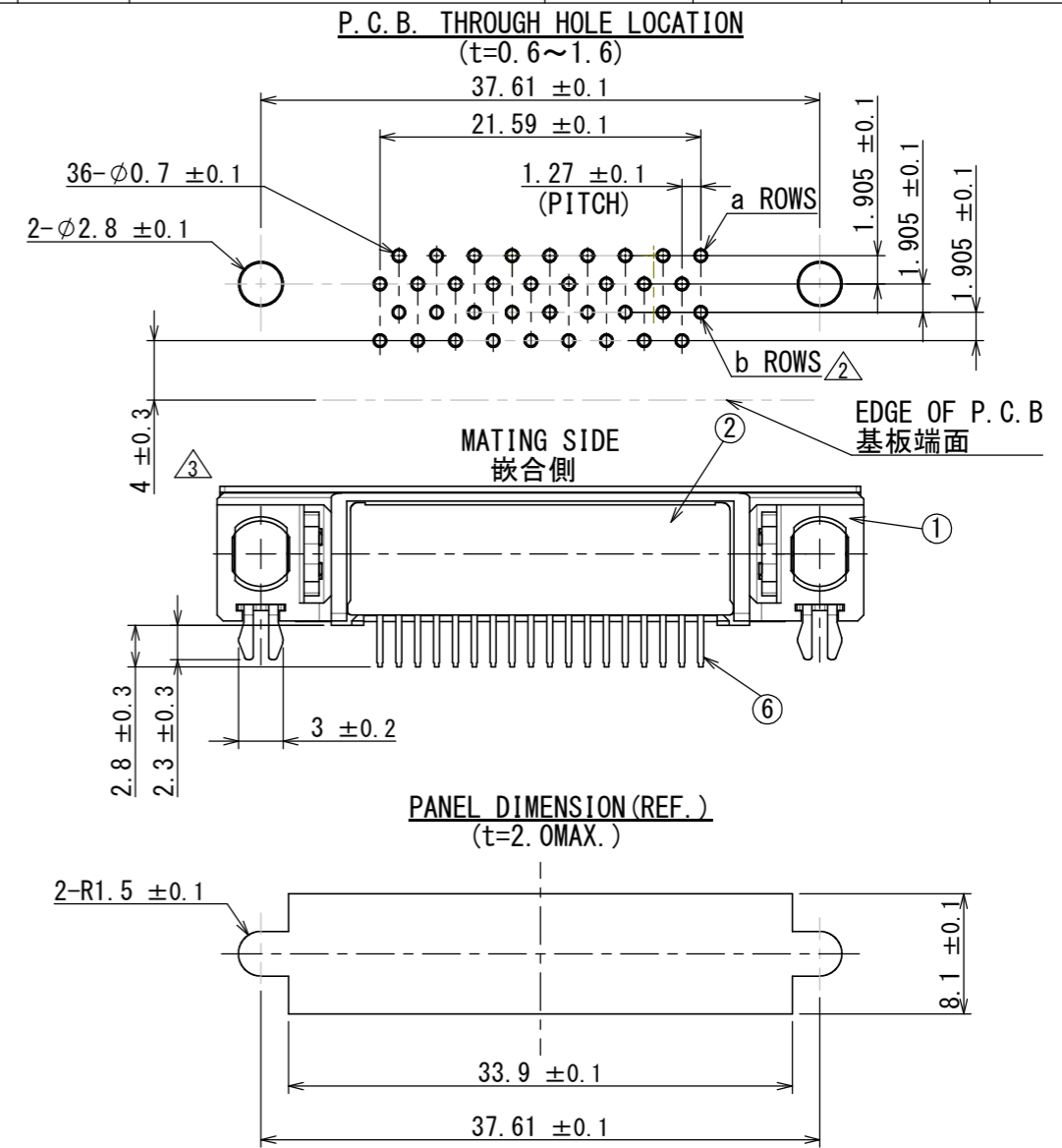
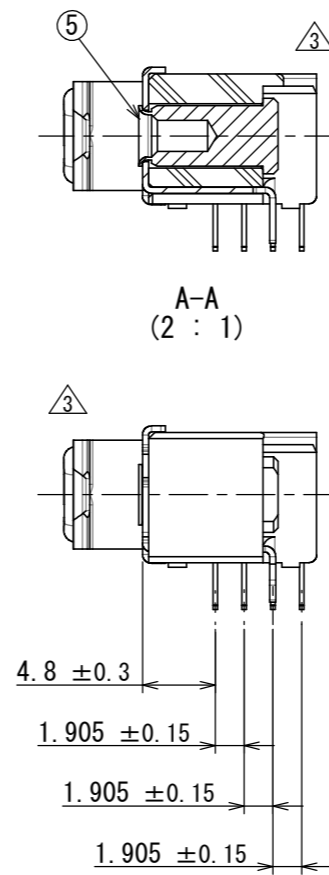
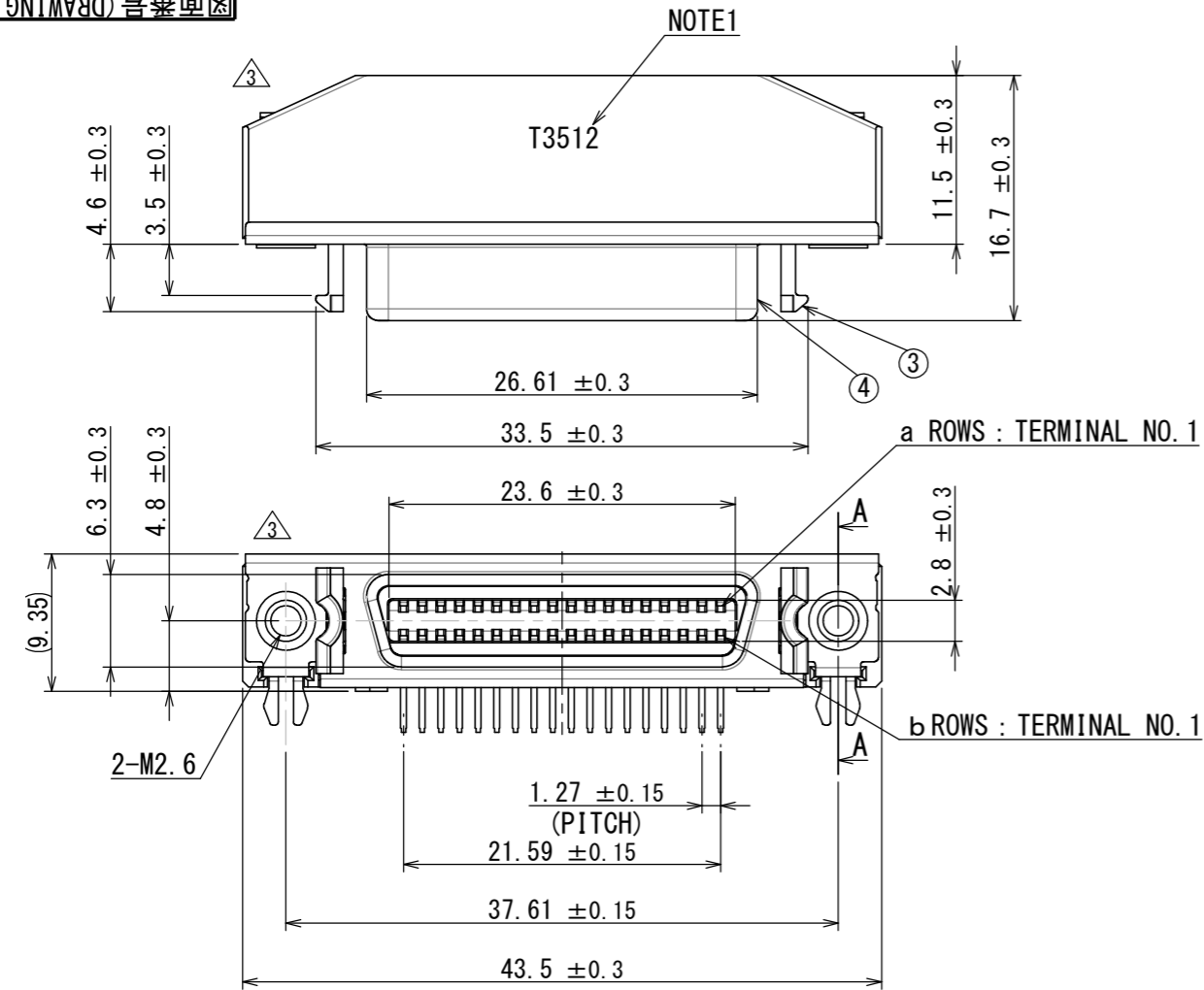

NOTE 1. PRODUCTION LOT NUMBER IS SHOWN AS INDICATED.  
LOT NO. IS MARKED AS SHOWN IN BELOW FIGURE MAKING.

注1. 図示の位置にロットNo. を表示する。表示方法は下記による。

Lot NO. (Ex.)  
ロット NO. (例.)

I 3 5 1 2

Manufacture day.  
製造日

Manufacture month. (JAN. TO SEP. : 1~9, OCT. : 0, NOV. : X, DEC. : Y)

製造月 (1月~9月: 1~9, 10月: 0, 11月: X, 12月: Y)

Manufacture year. (It is shown at A.D. 1 digit.)

製造年 (西暦の下1桁で表示する。)

IDENTIFICATION CODE (T: JAE Taiwan, Ltd)

組立部門識別 (T: JAE Taiwan, Ltd)

符号 NO.	名称 DESCRIPTION	個数 QTY.	材料 MATERIAL	仕上 FINISH	備考 REMARKS
6	CONTACT	36	COPPER ALLOY	CONTACT AREA: GOLD (0.1 μm MIN) TERMINAL AREA: TIN PLATING	-
5	NUT	2	COPPER ALLOY	NI OVER CU PLATING	-
4	SHELL	1	STEEL	TIN PLATING	-
3	LUG	2	STEEL	NI PLATING	-
2	LOCATOR	1	GLASS FILLED 9T NYLON	-	-
1	INSULATOR	1	GLASS FILLED 9T NYLON	-	-

仕様書 (SPECIFICATION) JACS-30303		第1版 (ORIGINAL DATE) 24/SEP/2013		尺度 (SCALE) 2:1		シリーズ (SERIES) DF02		日本航空電子工業株式会社	
一般公差 (GENERAL TOLERANCE)		製図 DR.		名称 (TITLE) DF02R036NA1		JAE		JAPAN AVIATION ELECTRONICS INDUSTRY, LTD.	
寸法 (DIMENSION)		担当 CHK. O. TAKAGI		質量 (MASS)		図面番号 (DRAWING NO.) SJ114514		版数 (VER.) 3	
角度 (ANGLES)		査閲 APPD. -		承認 APPD. T. MIYASHITA		-		-	
単位 (UNIT) : mm		-		-		-		-	

DCF-C-212H(12.08)

