



Chipsmall Limited consists of a professional team with an average of over 10 year of expertise in the distribution of electronic components. Based in Hongkong, we have already established firm and mutual-benefit business relationships with customers from,Europe,America and south Asia,supplying obsolete and hard-to-find components to meet their specific needs.

With the principle of “Quality Parts,Customers Priority,Honest Operation,and Considerate Service”,our business mainly focus on the distribution of electronic components. Line cards we deal with include Microchip,ALPS,ROHM,Xilinx,Pulse,ON,Everlight and Freescale. Main products comprise IC,Modules,Potentiometer,IC Socket,Relay,Connector.Our parts cover such applications as commercial,industrial, and automotives areas.

We are looking forward to setting up business relationship with you and hope to provide you with the best service and solution. Let us make a better world for our industry!



Contact us

Tel: +86-755-8981 8866 Fax: +86-755-8427 6832

Email & Skype: info@chipsmall.com Web: www.chipsmall.com

Address: A1208, Overseas Decoration Building, #122 Zhenhua RD., Futian, Shenzhen, China



Contact No.1 marking

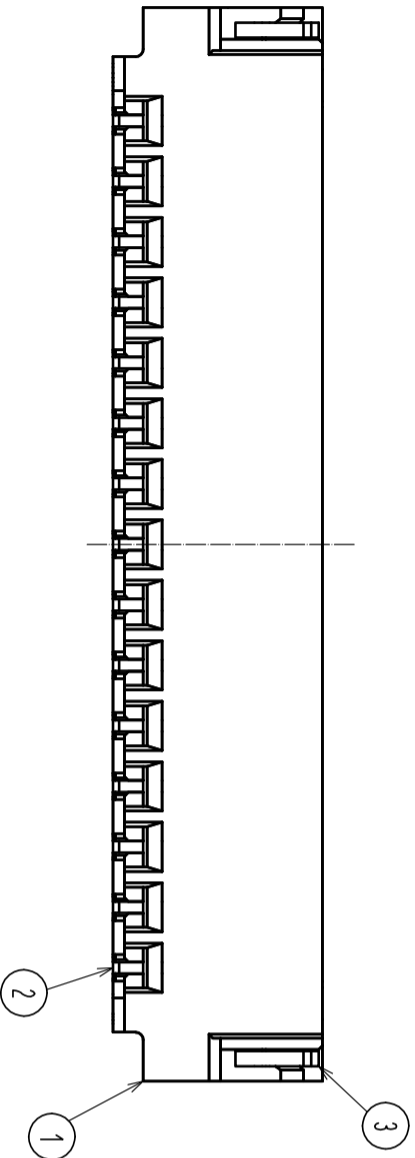
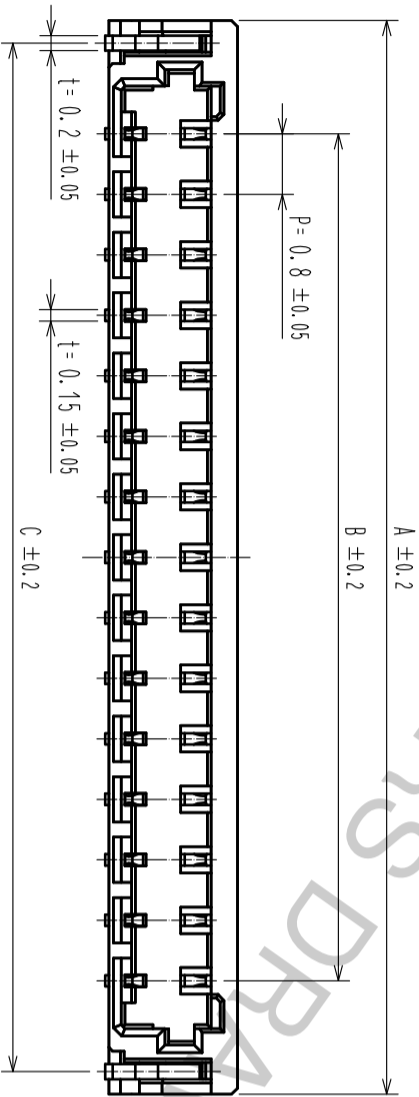
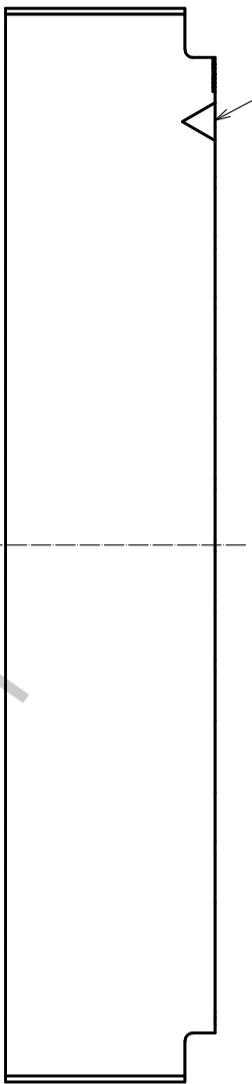

HRS marking

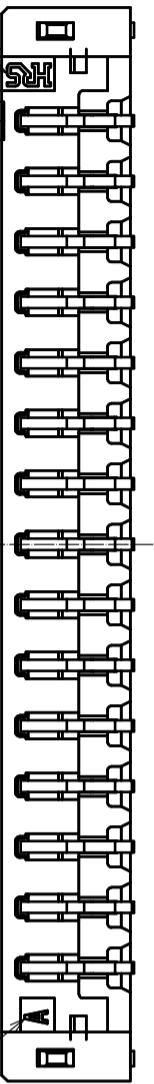

Cavity No.

Note 1. Lead co-planarity shall be 0.1mm MAX.
2. Please consult HIROSE when the product is mounted to FPC.

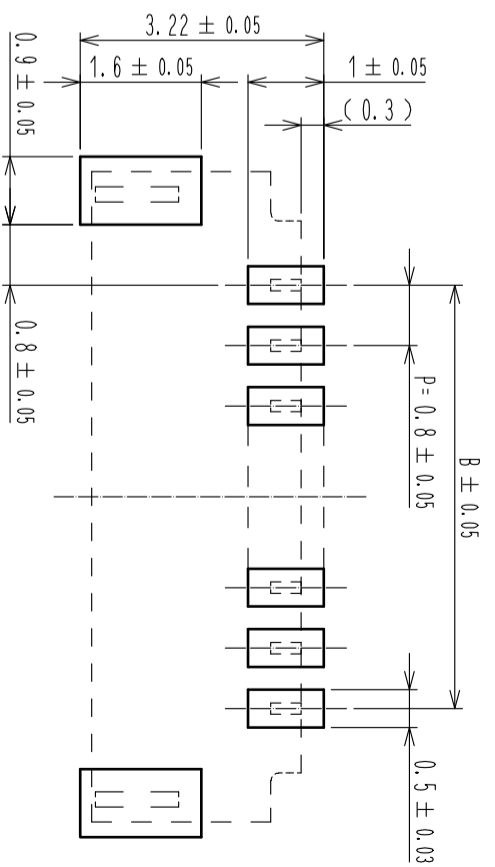
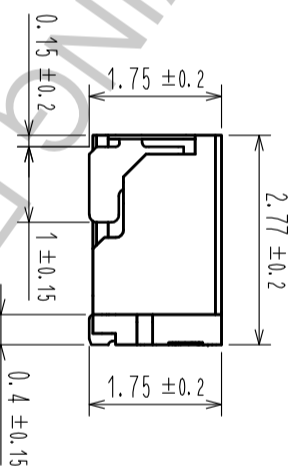

Recommended PCB layout
Recommended metal mask (thickness:0.1mm)

Mating Figure (Free)

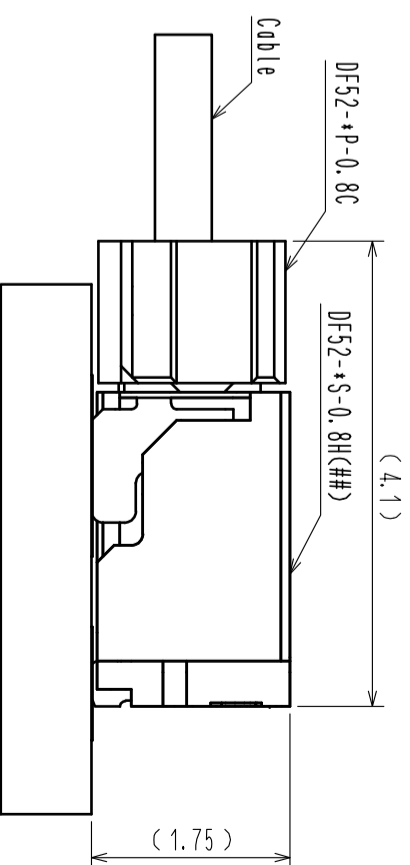

Part No.	Code No.	A	B	C
DF52-2S-0.8H(21)	CL0668-0004-5-21	3.8	0.8	3.2
DF52-3S-0.8H(21)	CL0668-0022-7-21	4.6	1.6	4.0
DF52-4S-0.8H(21)	CL0668-0005-8-21	5.4	2.4	4.8
DF52-5S-0.8H(21)	CL0668-0023-0-21	6.2	3.2	5.6
DF52-6S-0.8H(21)	CL0668-0006-0-21	7.0	4.0	6.4
DF52-8S-0.8H(21)	CL0668-0007-3-21	8.6	5.6	8.0
DF52-10S-0.8H(21)	CL0668-0008-6-21	10.2	7.2	9.6
DF52-12S-0.8H(21)	CL0668-0009-9-21	11.8	8.8	11.2
DF52-14S-0.8H(21)	CL0668-0024-2-21	13.4	10.4	12.8
DF52-15S-0.8H(21)	CL0668-0010-8-21	14.2	11.2	13.6
DF52-16S-0.8H(21)	CL0668-0025-5-21	15.0	12.0	14.4
DF52-17S-0.8H(21)	CL0668-0001-7-21	15.8	12.8	15.2
DF52-20S-0.8H(21)	CL0668-0011-0-21	18.2	15.2	17.6

3	Copper alloy	Surface:tin plating 1μmMIN	6	PS	Black(Reel)
2	Copper alloy	Surface:tin plating 1μmMIN	5	Polyester	Clear(Cover tape), ANTI-STATIC
1	Polyamide	Black, UL94V-0	4	PS	Clear(Embossed carrier tape), ANTI-STATIC
NO.	MATERIAL	FINISH . REMARKS	NO.	MATERIAL	FINISH . REMARKS
UNITS	mm	SCALE	10 : 1	COUNT	3
		HIROSE ELECTRIC CO., LTD. Approved : KI. AKIYAMA 14.06.27 Checked : HK. UMEHARA 14.06.27 Designed : TH. YOSHIZAMA 14.06.26 Drawn : TH. YOSHIZAMA 14.06.26			
		DIS-H-00002680 Description of Revisions No. 1 Date 17.03.10 Designer HK. HAYASHI Checker TS. FUKUSHIMA Drawing No. EDC3-356517-01 Part No. DF52-*S-0.8H(21) Code CL668-			

Drawing for packing (Free)

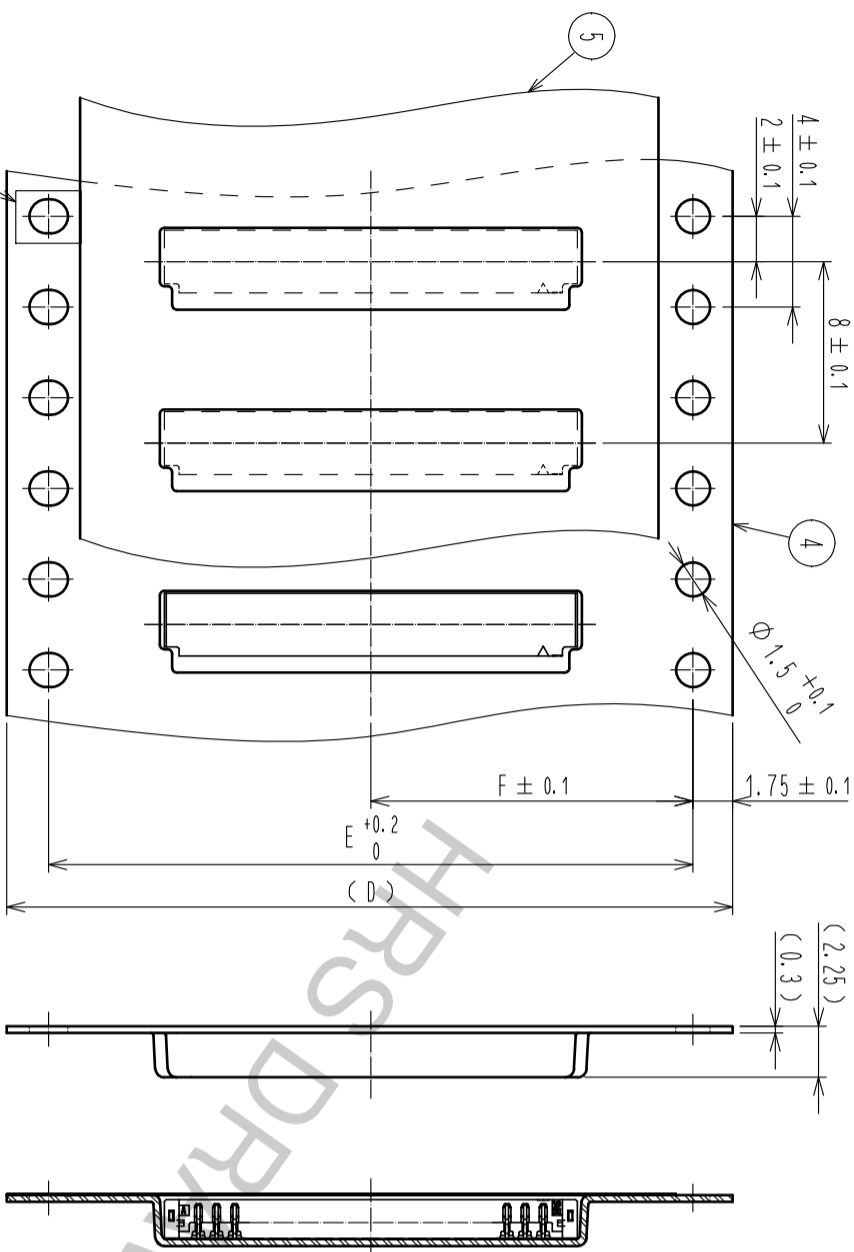

Style and dimension of reel (Free)

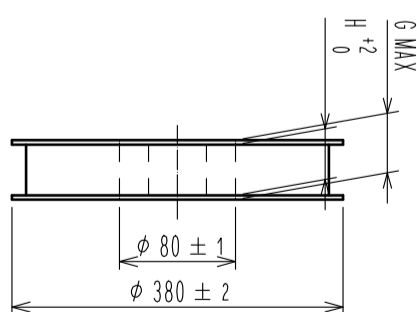
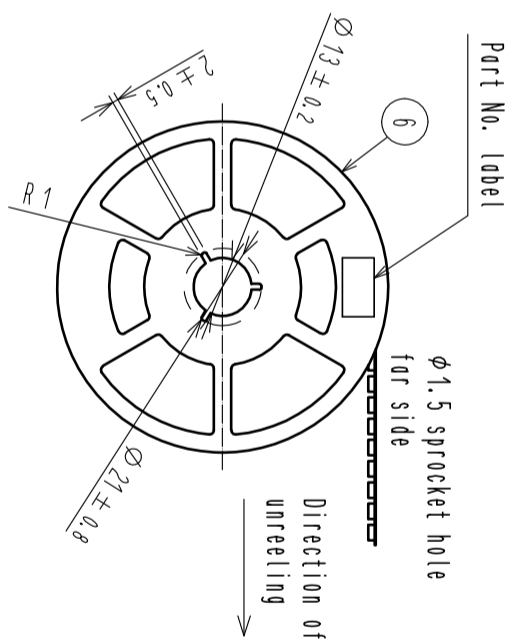

Detail of part No. label

Lot No.	170 7010
CL Code	CL668-0001-7-21
品名 (Part Number)	DF52-17S-0.8H(21)
納入数量 (Qty)	5000 K0
ヒロセ電機 (株)	

Reflow temperature profile using lead-free solder paste (Reference)

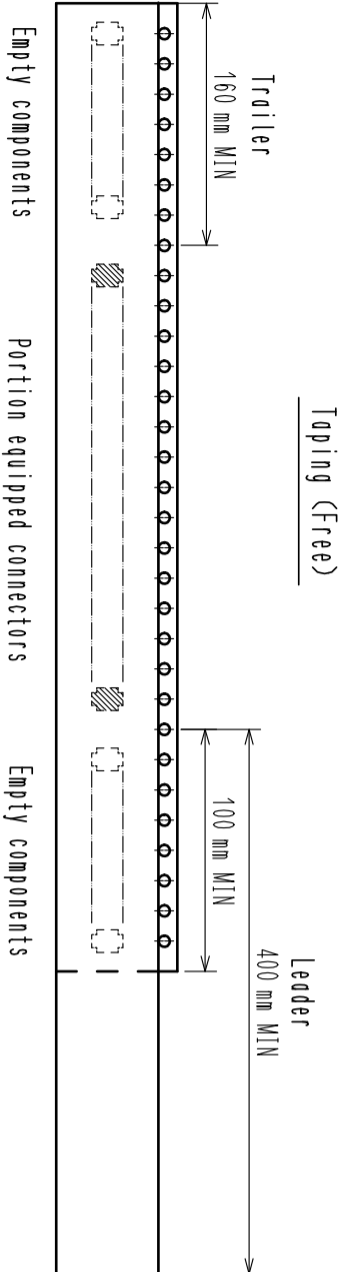
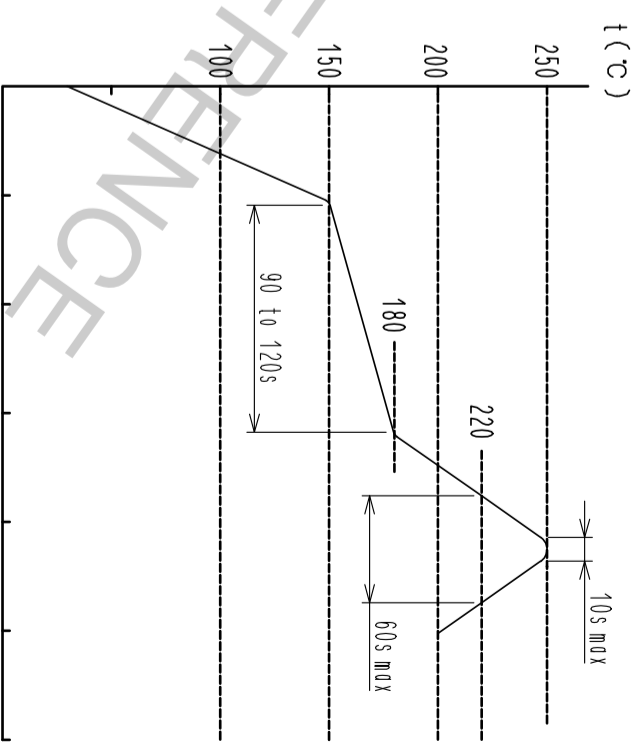

Taping (Free)

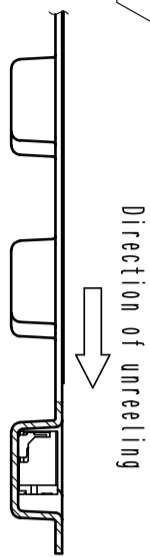

Note

- 1 reel: 5000 connectors.
- () is reference dimension.
- When the tape width is 32mm, sprocket holes shall be set on both side of reel as shown on this drawing.
- Refer to JIS C 0806. (Packaging of components for automating handling)
- Each meaning of Lot No. are shown below.

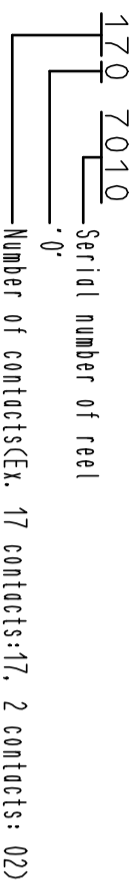

Part No.	Code No.	D	E	F	G	H
DF52-2S-0.8H(21)	CL0668-0004-5-21	16.0	7.5	22.4	16.4	16.4
DF52-3S-0.8H(21)	CL0668-0022-7-21	16.0	7.5	22.4	16.4	16.4
DF52-4S-0.8H(21)	CL0668-0005-8-21	16.0	7.5	22.4	16.4	16.4
DF52-5S-0.8H(21)	CL0668-0023-0-21	16.0	7.5	22.4	16.4	16.4
DF52-6S-0.8H(21)	CL0668-0006-0-21	16.0	7.5	22.4	16.4	16.4
DF52-8S-0.8H(21)	CL0668-0007-3-21	24.0	11.5	30.4	24.4	24.4
DF52-10S-0.8H(21)	CL0668-0008-6-21	24.0	11.5	30.4	24.4	24.4
DF52-12S-0.8H(21)	CL0668-0009-9-21	24.0	11.5	30.4	24.4	24.4
DF52-14S-0.8H(21)	CL0668-0024-2-21	24.0	11.5	30.4	24.4	24.4
DF52-15S-0.8H(21)	CL0668-0010-8-21	24.0	11.5	30.4	24.4	24.4
DF52-16S-0.8H(21)	CL0668-0025-5-21	24.0	11.5	30.4	24.4	24.4
DF52-17S-0.8H(21)	CL0668-0001-7-21	24.0	11.5	30.4	24.4	24.4
DF52-20S-0.8H(21)	CL0668-0011-0-21	32.0	28.4	38.4	32.4	32.4

Number of reflow cycles 2 cycles MAX.

The temperature is measured in the terminal lead part.

Additional factors, such as solder paste type, PCB size and other mounted components could affect the profile, therefore, a thorough evaluation of mounting condition is required prior to production.

HRS

DRAWING NO. EDC3-356517-01

PART NO. DF52-*S-0.8H(21)

CODE CL668-