



Chipsmall Limited consists of a professional team with an average of over 10 year of expertise in the distribution of electronic components. Based in Hongkong, we have already established firm and mutual-benefit business relationships with customers from,Europe,America and south Asia,supplying obsolete and hard-to-find components to meet their specific needs.

With the principle of “Quality Parts,Customers Priority,Honest Operation,and Considerate Service”,our business mainly focus on the distribution of electronic components. Line cards we deal with include Microchip,ALPS,ROHM,Xilinx,Pulse,ON,Everlight and Freescale. Main products comprise IC,Modules,Potentiometer,IC Socket,Relay,Connector.Our parts cover such applications as commercial,industrial, and automotives areas.

We are looking forward to setting up business relationship with you and hope to provide you with the best service and solution. Let us make a better world for our industry!



Contact us

Tel: +86-755-8981 8866 Fax: +86-755-8427 6832

Email & Skype: info@chipsmall.com Web: www.chipsmall.com

Address: A1208, Overseas Decoration Building, #122 Zhenhua RD., Futian, Shenzhen, China



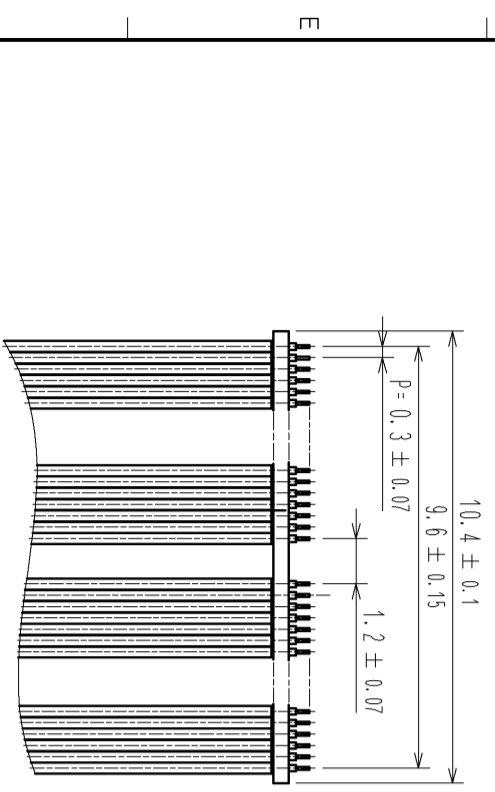
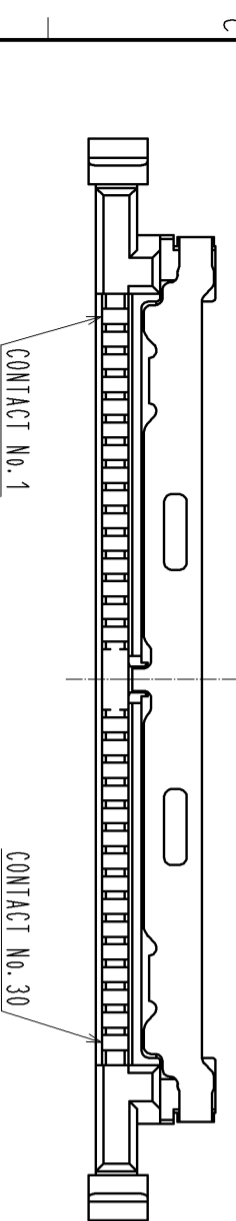
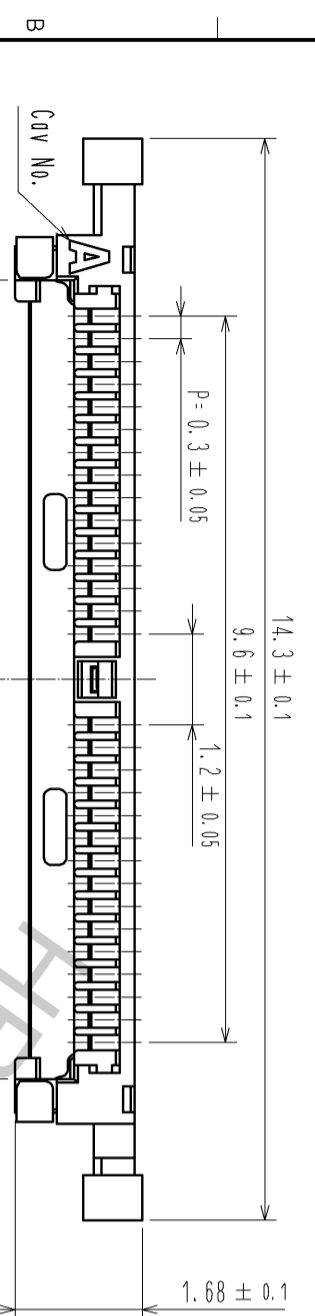

RECOMMENDED CABLE SUBASSEMBLY

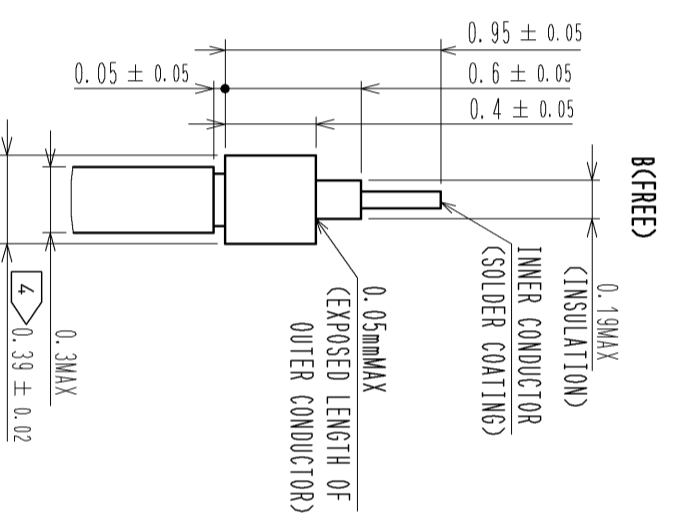
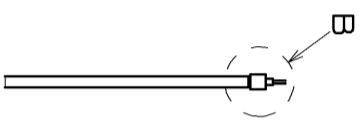

(FREE)

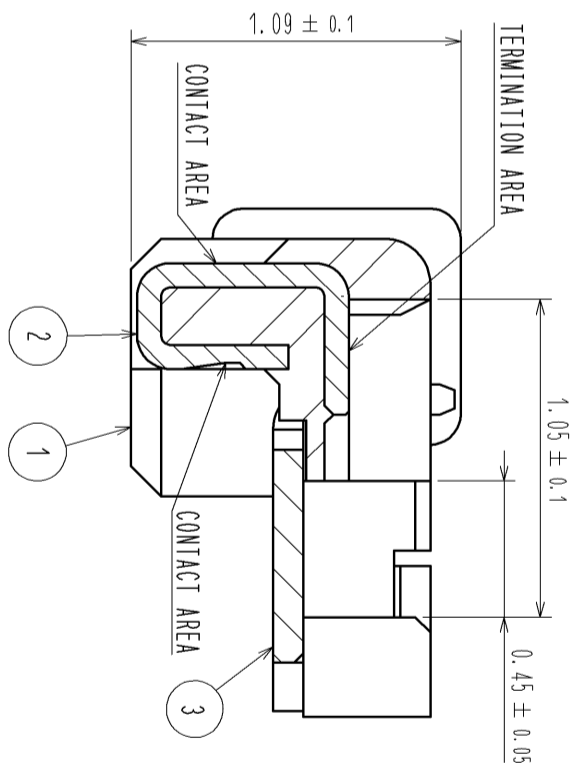

A-A (40 : 1)

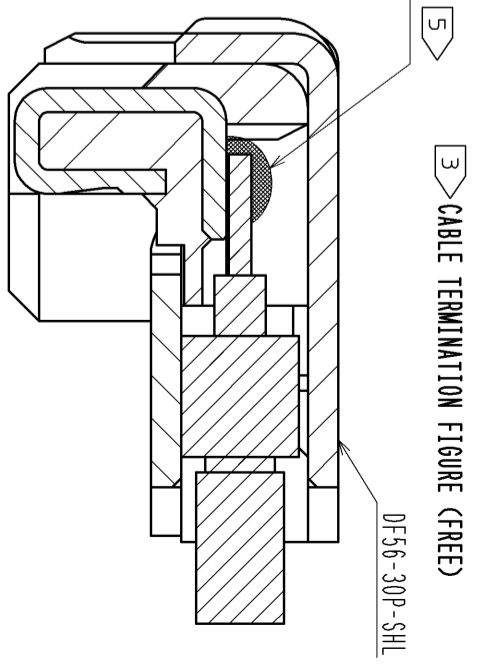

3 CABLE TERMINATION FIGURE (FREE)

ITEM No.	PART NAME	PART No.	CODE No.
1, 2, 3	CONNECTOR UNIT	DF56-30P-0.3SD(51)	CL662-5617-3-51
-	METAL SHIELDING	DF56-30P-SHL	CL662-5618-6-00

NOTES

1. APPLICABLE CABLE: MICRO COAXIAL CABLE(AWG#42~AWG#46)
2. THIS CONNECTOR IS NOT HOT PLUGGABLE. MATE AND UNMATE WHILE THE POWER IS OFF.
3. THE ASSEMBLY IS COMPLETED BY COMBINING TWO PARTS: CONNECTOR UNIT, AND METAL SHIELDING. REFER TO THE TABLE FOR EACH ITEM No., PART NAME, PART No AND CODE No.
4. SOLDER A GRAND BAR WITH AN EXTERNAL CONDUCTOR OF THE CABLE ABOUT STICKING A GRAND BAR TOGETHER.
5. PLEASE CONSULT ABOUT THE USE OF THE POTTING AND KAPTON TAPE SEPARATELY.

NO.	MATERIAL	FINISH	REMARKS	NO.	MATERIAL	FINISH	REMARKS
1	LCP	UL94V-0	BLACK	3	STAINLESS		WHOLE AREA : Sn PLATING 1.4μ min UNDER PLATING : Ni 0.24μ min
2	PHOSPHOR BRONZE			4	PS	CLEAR	
		CONTACT AREA : Au PLATING 0.14μ min		5	POLYESTER	CLEAR	
		TERMINATION AREA : Au PLATING 0.14μ min		6	PS	BLACK	
		UNDER PLATING : Ni PLATING 1.4μ min					

UNITS	SCALE	COUNT	DESCRIPTION OF REVISIONS	DESIGNED	CHECKED	DATE
mm	FREE					

APPROVED : TS. SAKATA	12.06.12	DRAWING NO.	EDC3-344841-01
CHECKED : HS. OZAWA	12.06.12	PART NO.	DF56-30P-0.3SD(51)
DESIGNED : TP. MATSUMOTO	12.06.12	CODE NO.	CL662-5617-3-51
DRAWN : TP. MATSUMOTO	12.06.12		



HIROSE ELECTRIC CO., LTD.

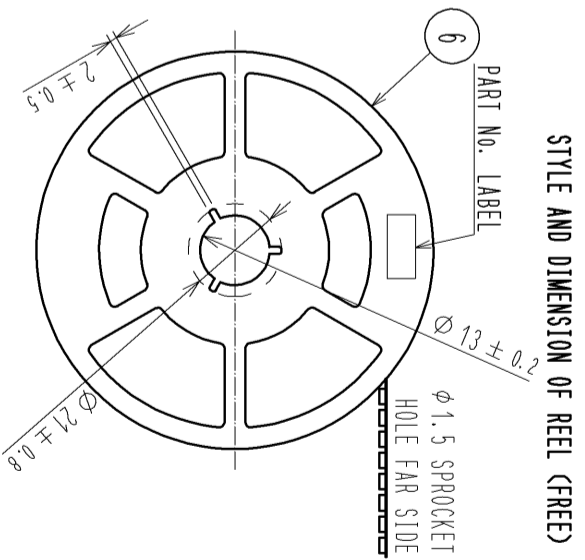
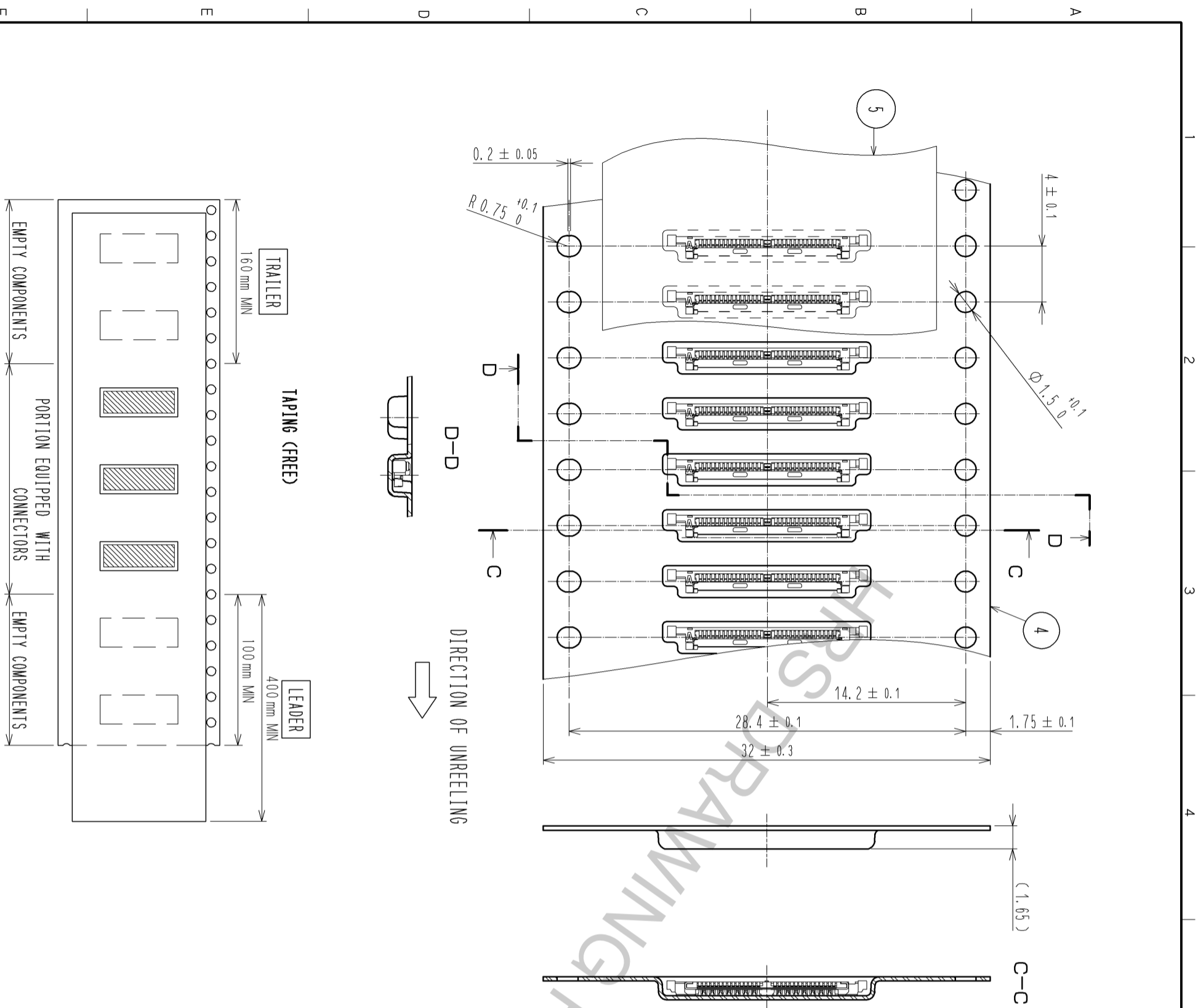

DETAIL OF PART NO. LABEL

生産月日	年月日
図番	CL662-5617-3-51
品名	DF56-30P-0.3SD(51)
納入数量	10000個
納入者	ヒロセ電機株式会社

SUPPLIER
QUANTITY
PART No.
CODE No.
DATE OF MANUFACTURED

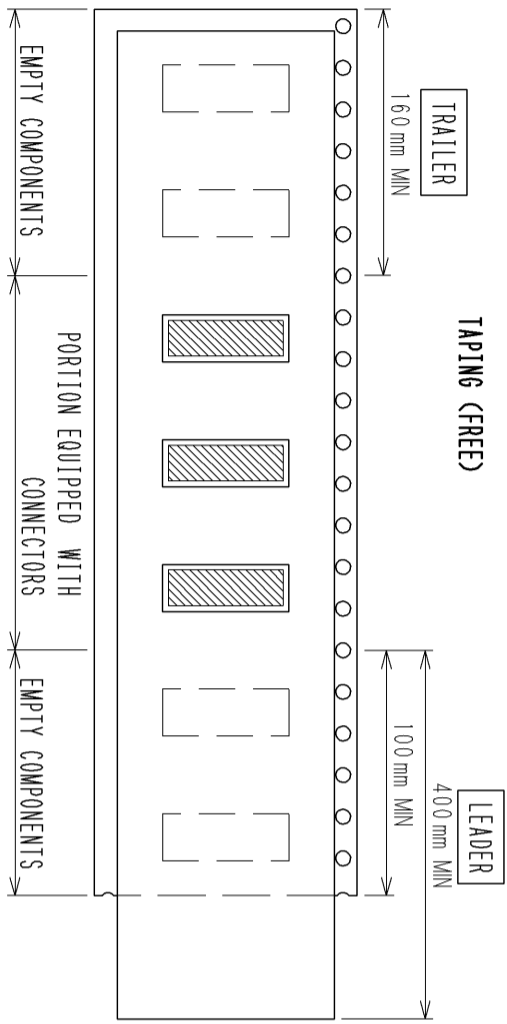
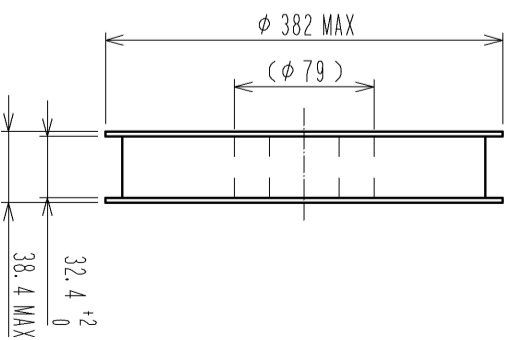

HRS

DRAWING NO.	EDC3-344841-01
PART NO.	DF56-30P-0.3SD(51)
CODE NO.	CL662-5617-3-51

2/2