



Chipsmall Limited consists of a professional team with an average of over 10 year of expertise in the distribution of electronic components. Based in Hongkong, we have already established firm and mutual-benefit business relationships with customers from,Europe,America and south Asia,supplying obsolete and hard-to-find components to meet their specific needs.

With the principle of “Quality Parts,Customers Priority,Honest Operation,and Considerate Service”,our business mainly focus on the distribution of electronic components. Line cards we deal with include Microchip,ALPS,ROHM,Xilinx,Pulse,ON,Everlight and Freescale. Main products comprise IC,Modules,Potentiometer,IC Socket,Relay,Connector.Our parts cover such applications as commercial,industrial, and automotives areas.

We are looking forward to setting up business relationship with you and hope to provide you with the best service and solution. Let us make a better world for our industry!



## Contact us

Tel: +86-755-8981 8866 Fax: +86-755-8427 6832

Email & Skype: info@chipsmall.com Web: www.chipsmall.com

Address: A1208, Overseas Decoration Building, #122 Zhenhua RD., Futian, Shenzhen, China



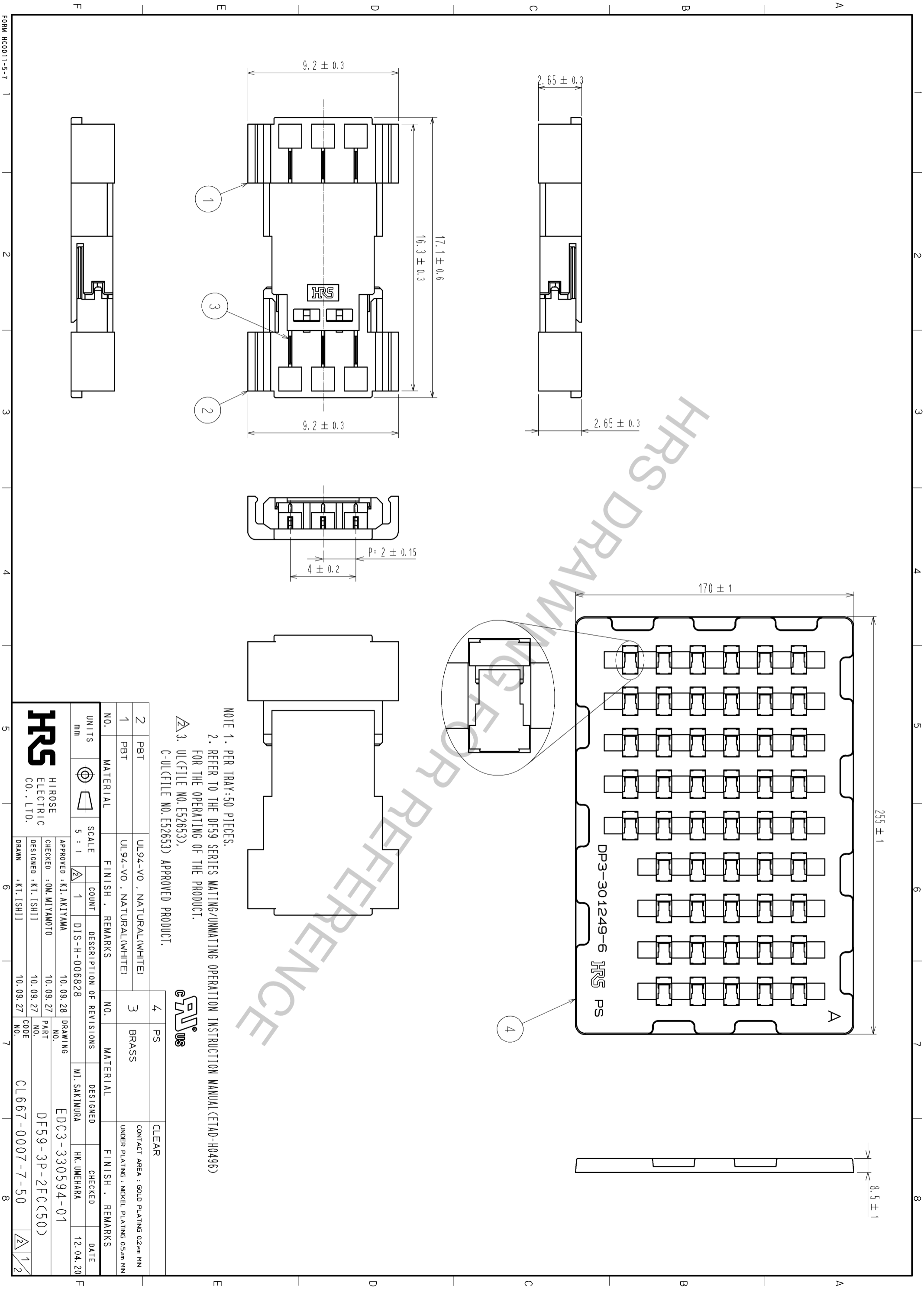

NOTE 1. PER TRAY:50 PIECES.  
 2. REFER TO THE DF59 SERIES MATING/UNMATING OPERATION INSTRUCTION MANUAL(ETAD-H0496)  
 FOR THE OPERATING OF THE PRODUCT.  
 3. UL(FILE NO.E52653),  
 C-UL(FILE NO.E52653) APPROVED PRODUCT.



2	PBT	UL94-V0, NATURAL(WHITE)	3	PS	CLEAR
1	PBT	UL94-V0, NATURAL(WHITE)			CONTACT AREA : GOLD PLATING 0.2μm MIN UNDER PLATING : NICKEL PLATING 0.5μm MIN
MATERIAL		FINISH . REMARKS	MATERIAL		FINISH . REMARKS
UNITS	SCALE	COUNT	DESCRIPTION OF REVISIONS	DESIGNED	CHECKED
mm	5 : 1	1	DIS-H-006828	MI.SAKIMURA	HK.UMEHARA
APPROVED : KI.AKIYAMA		10.09.28	DRAWING NO.		EDC3-330594-01
CHECKED : OM.MIYAMOTO		10.09.27	PART NO.		DF59-3P-2FC(50)
DESIGNED : KT.ISHII		10.09.27	CODE		CL667-0007-7-50
DRAWN : KT.ISHII		10.09.27	NO.		

FORM HC0011-5-7

# Operation Procedures for Floating Socket

## 【 Mating 】

1. Hold part A on the floating socket, and place it on the receptacle so that part A matches to part B.

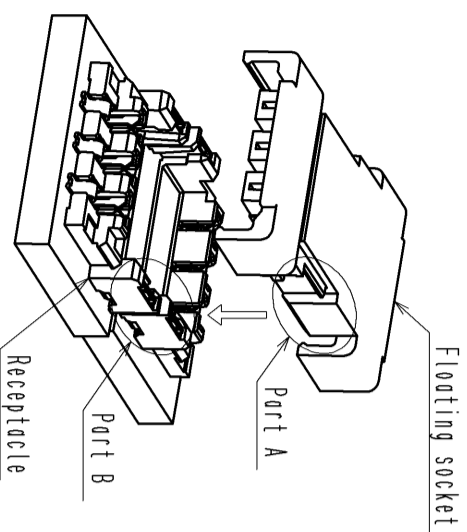

2. Align the floating socket edge on the side of friction lock to receptacle housing edge in a line. (Forcible mating without above alignment process could cause contact deformation.)

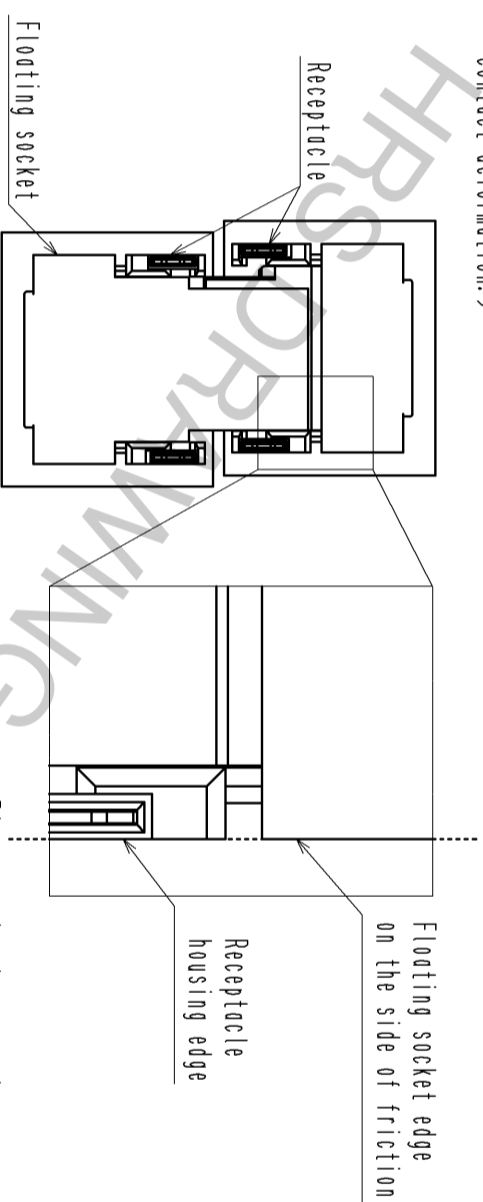

3. Press down at the center surface of the floating socket. (Press down until the floating socket touches to the receptacle.)

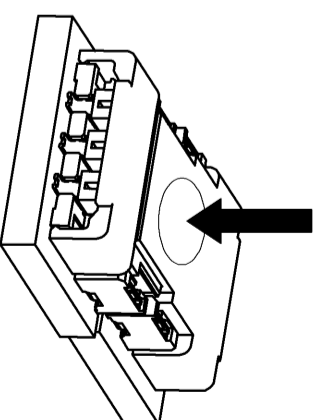

## 【 Umating 】

1. Hook the lever on either sides of socket with finger and lift up to the upper direction for unlock. (Lift up until friction lock is released.)

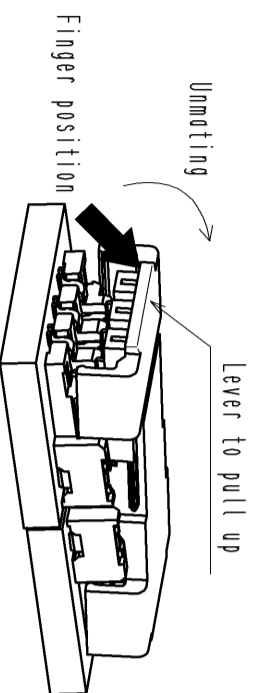

2. After releasing either side, hook the lever on the other side with a finger and lift up to the upper direction, too.

