



Chipsmall Limited consists of a professional team with an average of over 10 year of expertise in the distribution of electronic components. Based in Hongkong, we have already established firm and mutual-benefit business relationships with customers from,Europe,America and south Asia,supplying obsolete and hard-to-find components to meet their specific needs.

With the principle of "Quality Parts,Customers Priority,Honest Operation,and Considerate Service",our business mainly focus on the distribution of electronic components. Line cards we deal with include Microchip,ALPS,ROHM,Xilinx,Pulse,ON,Everlight and Freescale. Main products comprise IC,Modules,Potentiometer,IC Socket,Relay,Connector.Our parts cover such applications as commercial,industrial, and automotives areas.

We are looking forward to setting up business relationship with you and hope to provide you with the best service and solution. Let us make a better world for our industry!



Contact us

Tel: +86-755-8981 8866 Fax: +86-755-8427 6832

Email & Skype: info@chipsmall.com Web: www.chipsmall.com

Address: A1208, Overseas Decoration Building, #122 Zhenhua RD., Futian, Shenzhen, China



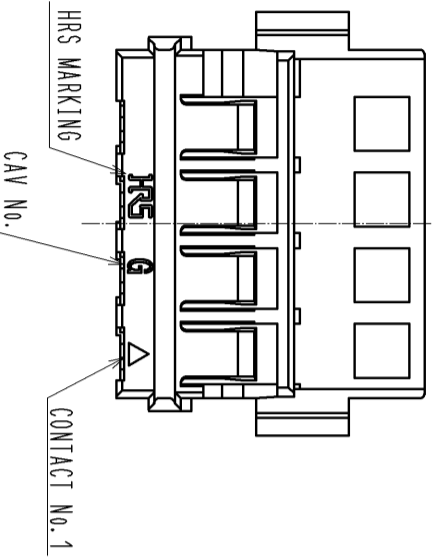
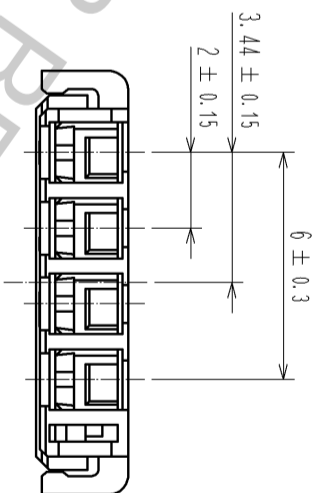
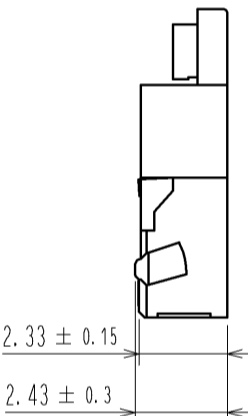
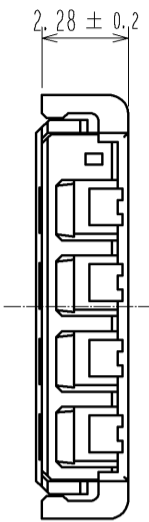
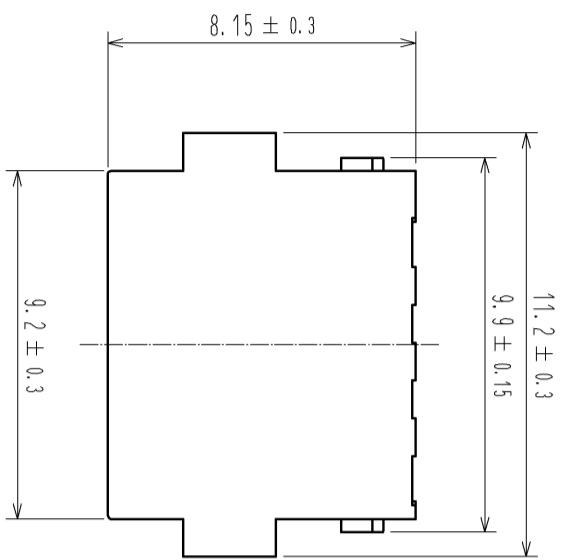

NOTE1. PER PACK : 100 PIECES

2. REFER TO THE DF59 SERIES MATING/UNMATING OPERATION INSTRUCTION MANUAL(ETAD-H0496)

3. UL(FILE NO. E52653),
C-UL(FILE NO. E52653) APPROVED PRODUCT.



NO.	MATERIAL	FINISH	REMARKS	NO.	MATERIAL	FINISH	REMARKS
1	PBT		UL94V-0, NATURAL(WHITE)				

UNITS	SCALE	COUNT	DESCRIPTION OF REVISIONS	DESIGNED	CHECKED	DATE
mm	5 : 1	1	DIS-H-006828	MI. SAKIMURA	HK. UMEHARA	12.04.20

APPROVED : KI. AKIYAMA	11.03.25	DRAWING NO.	EDC3-331128-01
CHECKED : OM. MIYAMOTO	11.03.25	PART NO.	DF59-4P-2C
DESIGNED : KT. ISHII	11.03.25	CODE NO.	CL667-0013-0-00
DRAWN : KT. ISHII	11.03.25		

Operation Procedures for Crimp Socket

【 Mating 】

1. By positioning the convexity of the crimp socket sides to the receptacle convexity, align the centers of the crimp socket and the receptacle in pitch direction.

2. Keep pressing down at the cable side and also apply force to the lever side to mate. (If the cable side floats before mating is finished, the lock may not work.)

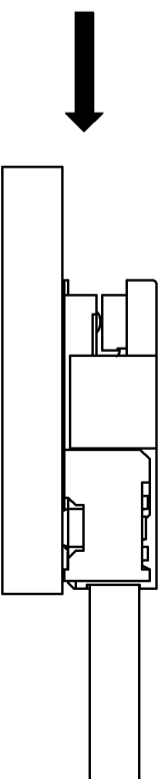
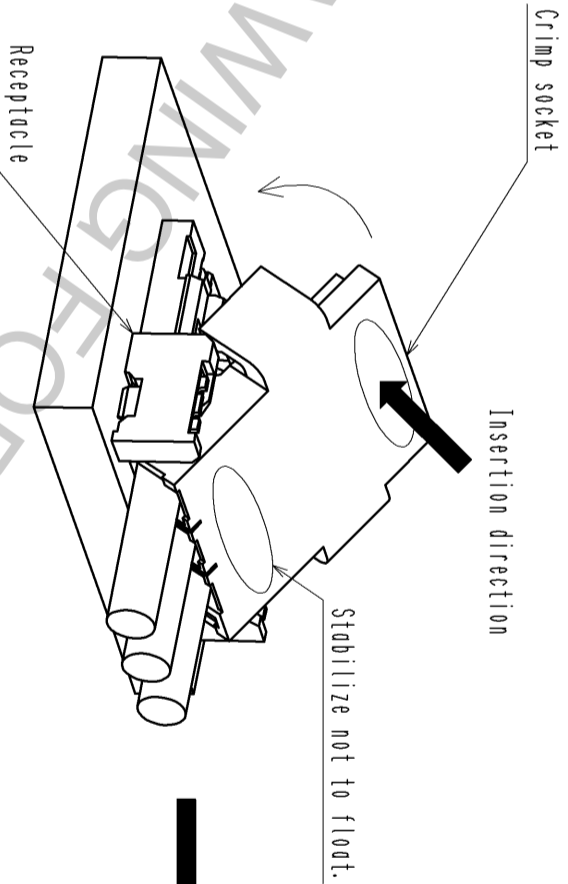
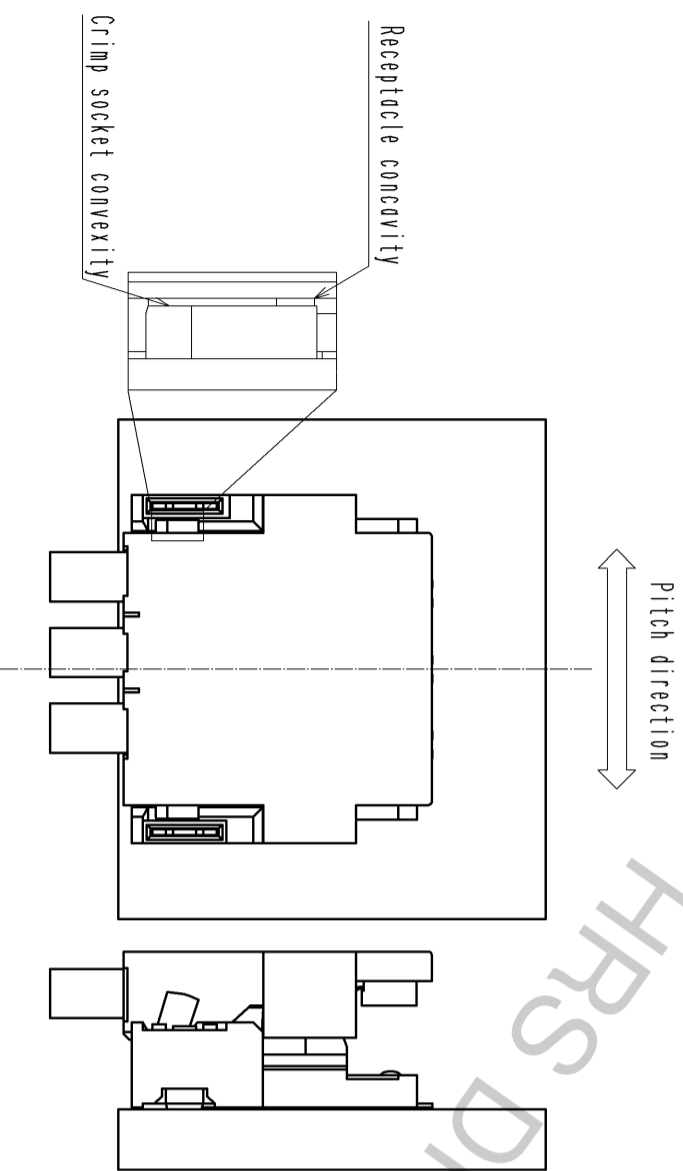

【 Unmating 】

1. Hook the lever with finger and lift up to the upper direction for unlock.

Note) When lifting up the lever, do not apply downward force to the cable side of the crimp socket. This could damage the connector.

Make sure to use the lever for removal operation.

If the cable is pull for removal, it could break the cable or damage the connector.

Unmating to pull up

