



Chipsmall Limited consists of a professional team with an average of over 10 year of expertise in the distribution of electronic components. Based in Hongkong, we have already established firm and mutual-benefit business relationships with customers from,Europe,America and south Asia,supplying obsolete and hard-to-find components to meet their specific needs.

With the principle of “Quality Parts,Customers Priority,Honest Operation,and Considerate Service”,our business mainly focus on the distribution of electronic components. Line cards we deal with include Microchip,ALPS,ROHM,Xilinx,Pulse,ON,Everlight and Freescale. Main products comprise IC,Modules,Potentiometer,IC Socket,Relay,Connector.Our parts cover such applications as commercial,industrial, and automotives areas.

We are looking forward to setting up business relationship with you and hope to provide you with the best service and solution. Let us make a better world for our industry!



## Contact us

Tel: +86-755-8981 8866 Fax: +86-755-8427 6832

Email & Skype: info@chipsmall.com Web: www.chipsmall.com

Address: A1208, Overseas Decoration Building, #122 Zhenhua RD., Futian, Shenzhen, China





# Commercial, construction and agricultural vehicles

Applications guide

[www.infineon.com/cav](http://www.infineon.com/cav)



# Contents

<b>Introduction</b>	<b>3</b>
<b>Challenges and opportunities in commercial, construction and agricultural vehicles (CAV)</b>	3
<b>Autonomous driving</b>	<b>4</b>
<b>24 GHz radar</b>	5
<b>24 V body applications</b>	<b>6</b>
<b>Body ECU</b>	7
<b>Seat control module</b>	8
<b>LED lighting</b>	9
<b>Low-voltage motor control</b>	<b>10</b>
<b>Brushless DC motor control</b>	11
<b>Brushed DC motor control</b>	12
<b>Unidirectional DC motor control</b>	13
<b>Hybrid electric solutions</b>	<b>14</b>
<b>Auxiliary applications</b>	15
<b>Powertrain inverter</b>	16
<b>Valve control</b>	<b>17</b>
<b>Hydraulic management system</b>	18
<b>Pneumatic management system</b>	19

# Challenges and opportunities in commercial, construction and agricultural vehicles (CAV)

**From autonomous driving to electrification, the biggest mobility megatrends of our time are shaping the field of commercial, construction and agricultural vehicles (CAV). Semi- and fully-autonomous vehicles present a range of new opportunities in terms of efficiency, precision and safety. Imagine machines that run 24/7 with no downtime. Tractors that independently navigate their surroundings and react based on data they collect. At the same time, electrification is increasingly attractive CAVs. Electric drivetrains help manufacturers comply with the latest emissions and energy regulations while operators look forward to greater yield rates.**

CAVs are under mounting pressure to provide highest-possible availability and lowest-possible operating costs as operators strive to maximize profits. This is true for agricultural and construction machines as well as trucks and buses. Electronic semiconductor-based systems already play a key role in making commercial vehicles and work machines more efficient. The next step: fully self-driving and self-operating vehicles. Used in agriculture, autonomous tractors can spread fertilizer and plant seeds with outstanding precision. Autonomous technologies also enable small, lightweight swarm robots to replace heavy machinery that is hard on fertile soil. They prevent overcrowding of farmland and can even individually treat plants with herbicides and pesticides. A practice that's kind to the environment – and to farmers' wallets.

Meanwhile, hybrid or fully electric drivetrains can reduce or even eliminate operators' fossil fuel consumption and reduce their CO<sub>2</sub> emissions. Compared to combustion ones, electric drivetrains are low maintenance, which results in less hassle and greater productivity. Today, electric drives controlled by modern power electronics can be used as a complement to or substitute for traditional drivetrain technologies. Electric machines can support or fully replace the combustion drive-

train in the engine. In hybrids, the combustion engine delivers part of the propulsive power, while the electric drive provides torque for peak loads. Such a system reduces fuel consumption and allows energy to be recovered during braking. This energy can later be used to accelerate the vehicle and boost fuel efficiency.

An electric motor can also operate as a starter-generator, reducing the drivetrain's complexity by combining the two parts. A diesel electric drivetrain concept is another alternative. Here, the generator provides the electric power needed to operate the vehicle, which is always driven electrically. A battery stores energy recovered during deceleration to ensure an independent energy supply is always available. With no gearbox or clutch, electric machines can provide maximum torque at zero speed – ideal for heavy-duty applications.

Finally, in the case of electric drives, an on-board energy storage solution, such as a battery or fuel cell, can provide enough energy to operate the vehicle for a reasonable length of time. In an electric forklift truck, for example, this could be a shift of several hours while a few minutes may be sufficient for an urban bus that can recharge at each bus stop. Eliminating the combustion engine also represents a major step in improving vehicle availability and reliability.

With proven expertise in CAV applications and a comprehensive portfolio of robust, high-quality control and power semiconductor solutions, Infineon helps designers and developers engineer CAVs that deliver greater fuel economy, productivity and reliability.



# Autonomous driving

Self-driving technologies have the potential to revolutionize the CAV sector. Today, operators want commercial vehicles with highest-possible availability and lowest-possible operating costs so they can maximize profitability. Electronic semiconductor-based systems already make trucks, buses, and agricultural and construction machines more efficient. Fully self-driving vehicles is the logical next step.

Driverless machines can operate 24/7 – whether on a construction site or the freeway. Autonomous systems eliminate the need for downtime as well as the most common cause of accidents: people. In agriculture, autonomous tractors can spread fertilizer and plant seeds with utmost precision. Thanks to autonomous technologies, small, lightweight swarm robots can replace heavy machinery that wears on the ground. They prevent overcrowding of farmland and can individually treat plants with herbicides and pesticides.

Autonomous vehicles are fitted with radar sensors to reliably and securely identify their surroundings. Navigation and telematics systems provide additional data, which power semiconductor collect and consolidate, then use to compute commands. Safety and security requirements for semiconductor systems are high. They must be robust enough to withstand harsh environments, such as temperature and vibration, and provide high-level functional safety. Furthermore, as an intricately connected system they must be protected against criminally-motivated manipulation.

# 24 GHz radar

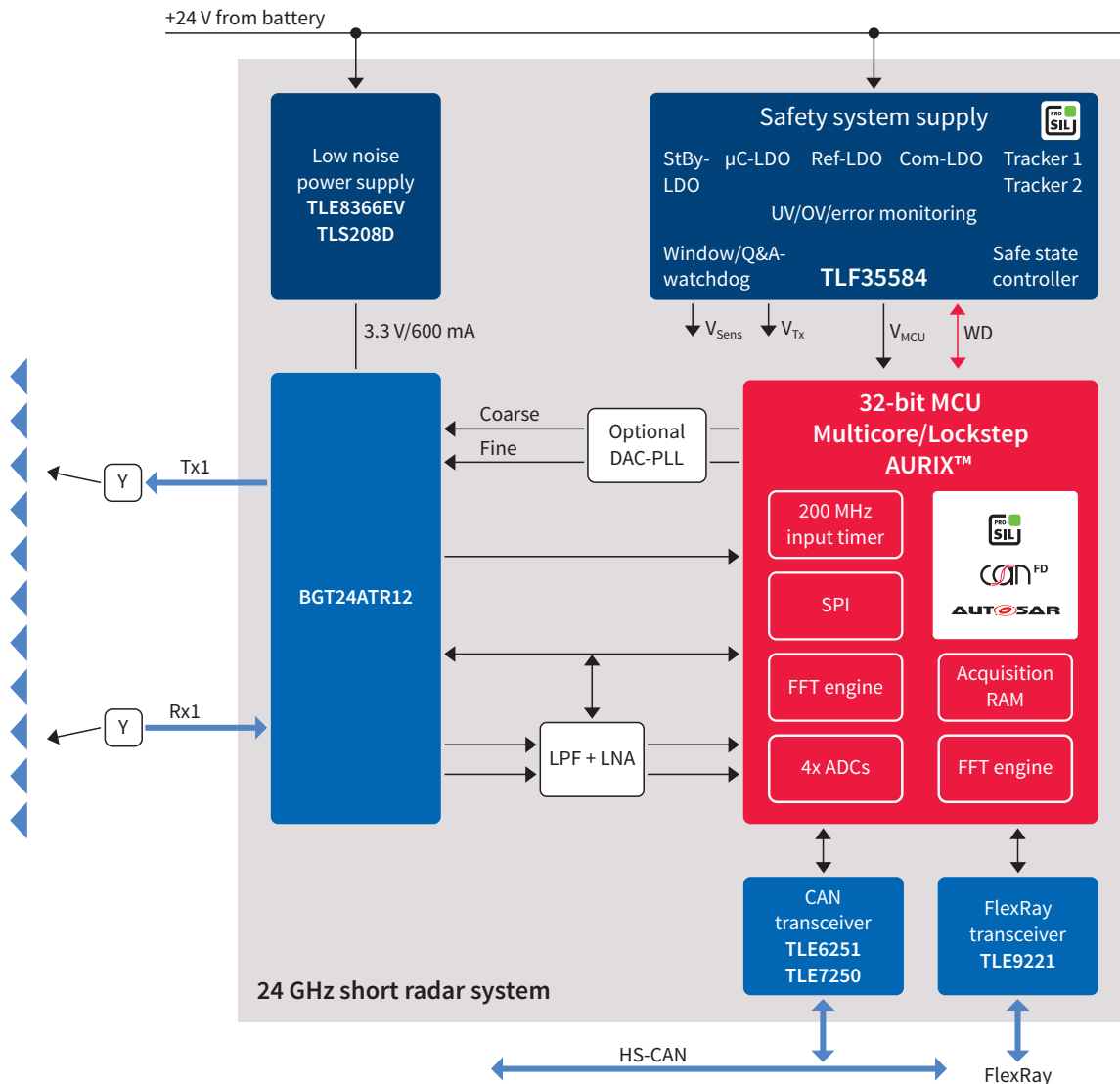

## System benefits

- › Complete CAV 24 GHz radar solution from our AURIX™ family
- › Lower development costs thanks to an integrated solution with ample storage
- › Reference designs save time and costs

## Suggested products



Product family	Description
AURIX™	Scalable 32-bit TriCore™ microcontroller family from single to multicore (PRO-SIL™)
TLF35584	System power supply with integrated watchdog (PRO-SIL™)
TLE9251SJ/TLE9251VSJ	CAN transceivers
TLE9221SX	FlexRay transceiver
BGT24ATR12	24 GHz radar 1-channel transmitter, 2-channel receiver IC
TLE8366EV/TLS208D	Low noise linear post regulators



## 24 V body applications

24 V body applications for trucks and agricultural vehicles fall into one of three categories: truck body electric control unit (ECU), seat control and LED lighting. To be successful, each relies on a 24 V semiconductor solution engineered to fulfill the CAV's high demands. Furthermore, each application has its own challenges to overcome. These include limited available space in ECU and seat control designs, and the demand for energy efficiency in LED lighting.

A truck's ECU must complete a growing list of functions in an increasingly smaller board space. Products for 24 V systems that offer a high level of integration are a viable solution. A 24 V seat control module must be compact and feature integrated motor drivers. With lighting now a major differentiator in vehicle design, demand has soared for highly flexible solutions that accommodate a broad spectrum of LED configurations in trucks, such as those with a highly efficient and flexible DC-DC controller. Operators also appreciate diagnostic features in LED light modules that inform them, for example, when a LED has burned out. Such solutions, however, should offer seamless functionality at a low price point.

# Body ECU

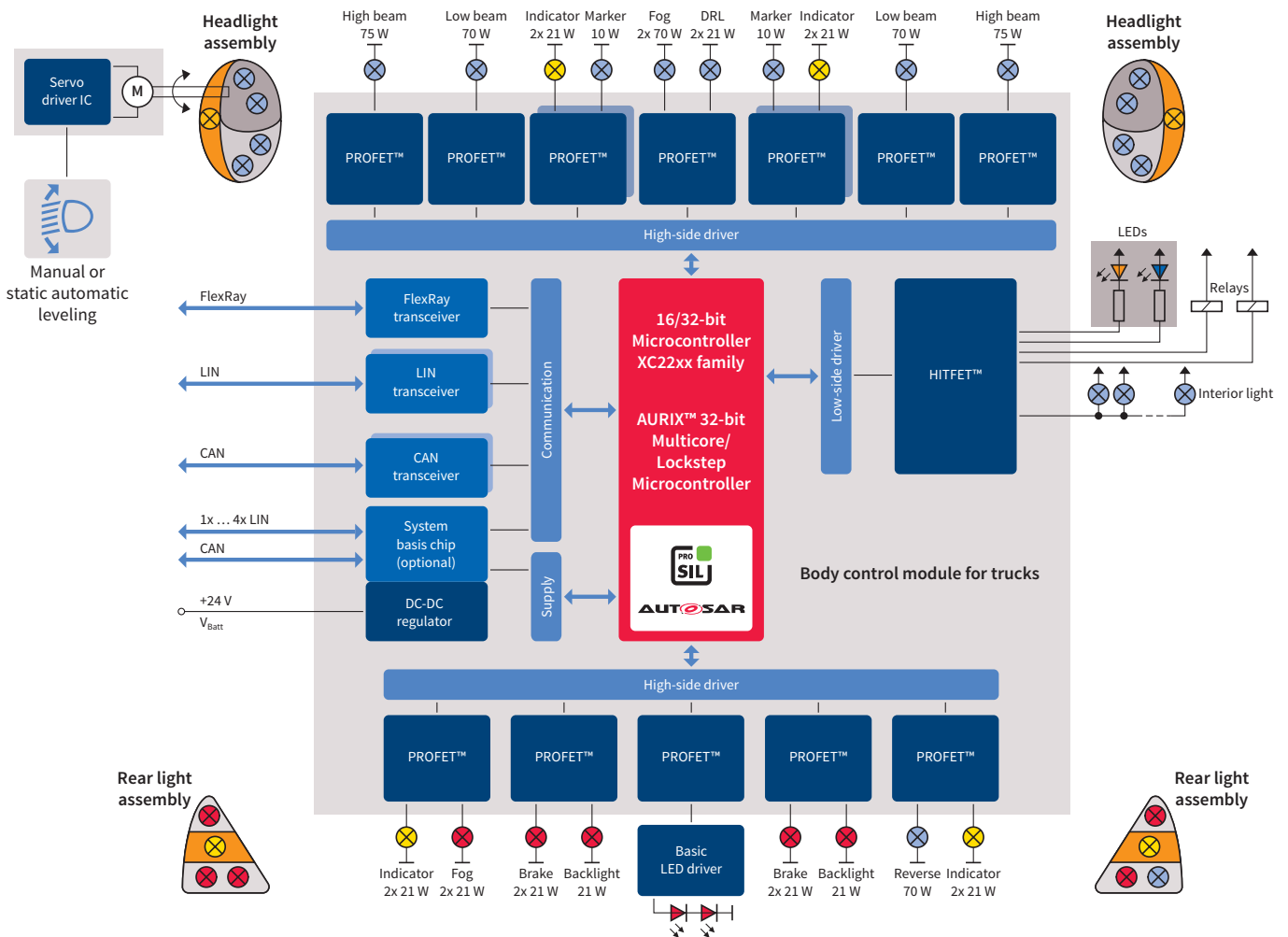

## System benefits

- › Reduced board space due to integrated functionality
- › PROFET™+ 24V provides excellent diagnostic and protection features and a high current sense accuracy, even for the smallest loads, such as LEDs
- › Supports the “Limp Home” functional safety concept
- › Maximum design flexibility and a lower design outlay due to identical footprint & pin-compatibility
- › Automotive LED driver products support the transition of lighting solutions to LED exclusively

## Suggested products



Product family	Description
AURIX™	Scalable 32-bit TriCore™ microcontroller family from single to multicore (PRO-SIL™)
Supply ICs	Voltage regulators, DC-DC converters
SPIDER, HITFET™ 24V	Low-side switches 24V: BTS3028, BT3046, BTS3104
LITIX™ Basic	Scalable linear current sources family for automotive LED applications
SBCs, network transceiver	System basis chips, CAN, LIN and FlexRay transceiver
PROFET™+ 24V	Single- and multi-channel protected high-side switches 24V



# Seat control module

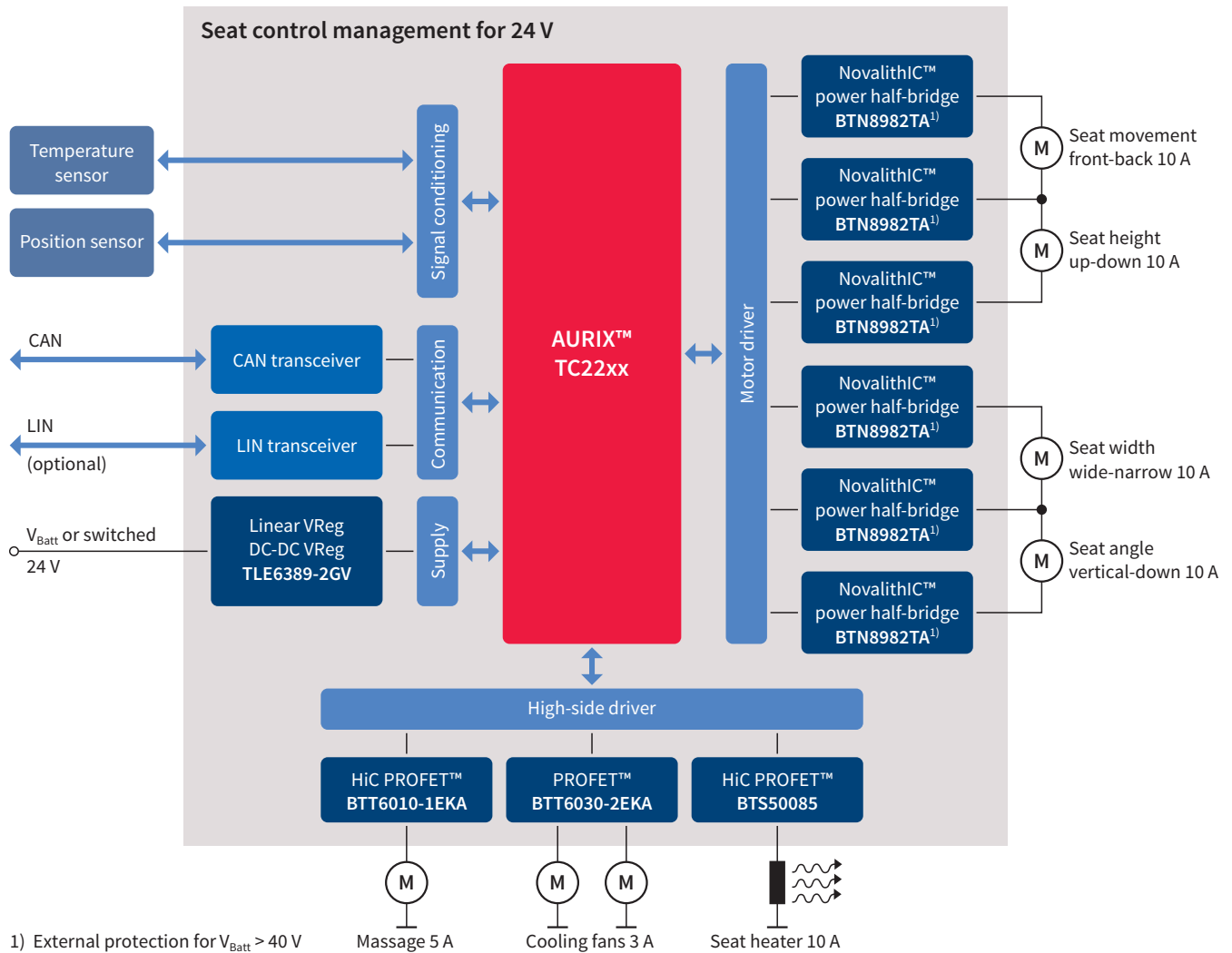

## System benefits

- › System-in-a-package solutions for high-power integrated and protected motor control
- › Reduced board space due to integrated functionality
- › Protected load control with sophisticated diagnostic features

## Suggested products

Product family	Description
AURIX™ TC22xL	Scalable 32-bit TriCore™ microcontroller family from single to multicore (PRO-SIL™)
NovalithIC™ BTN8982TA	Integrated half-bridge driver
High-current PROFET™	Smart low-ohmic high-side switches for heating applications
PROFET™+ 24V	Smart high-side switches for 24 V applications
TLE6389	DC-DC converter (automotive)
Network transceivers	LIN and CAN transceivers

# LED lighting

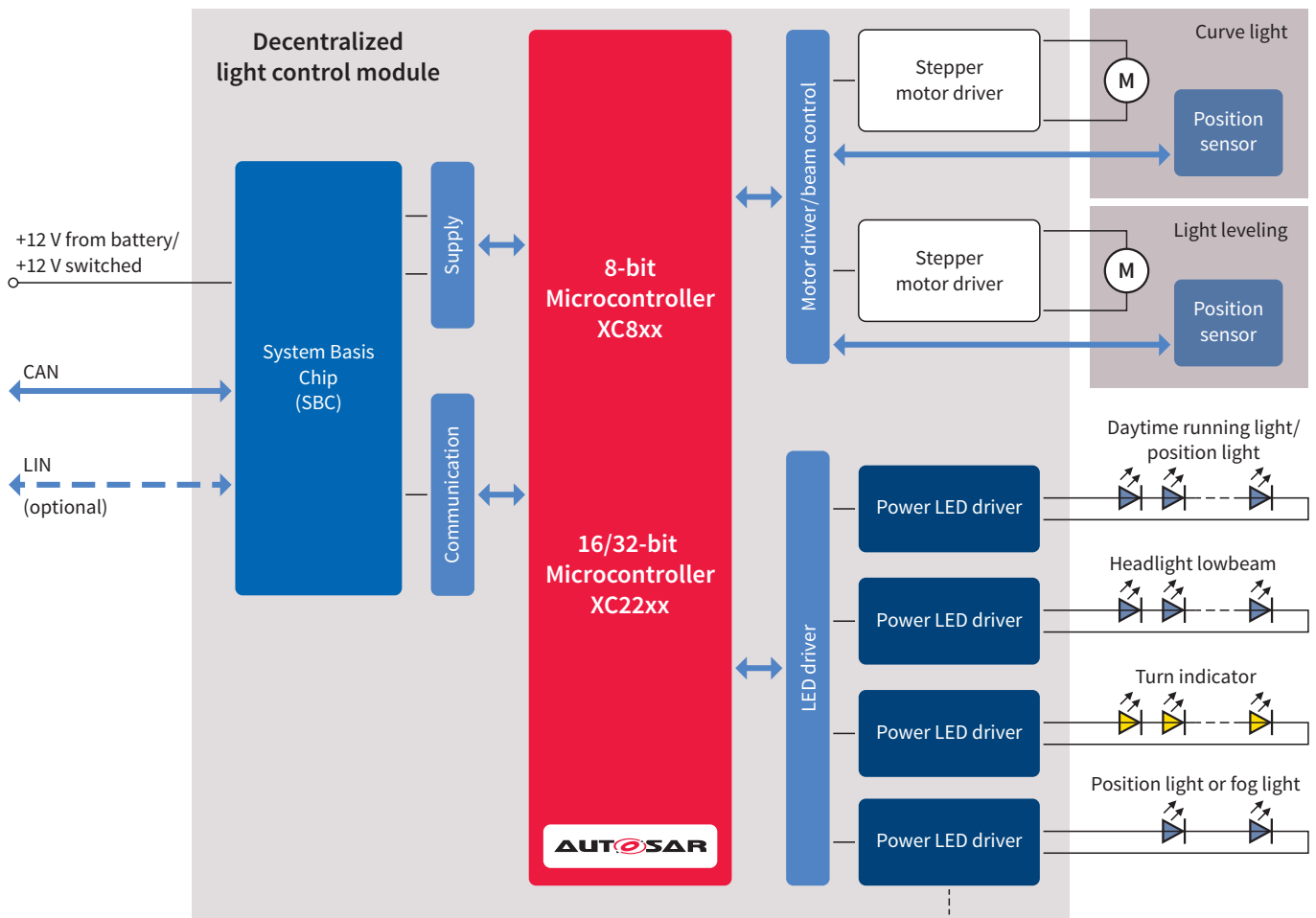

## System benefits

- › Automotive LED drivers for high-brightness LEDs
- › LED driver ICs support various DC-DC topologies (buck, boost, SEPIC)
- › Microcontroller peripherals for light control with a low CPU load
- › System basis chips combine the supply, network transceiver and monitoring functions in a monolithic device

## Suggested products

Product family	Description
AURIX™	32-bit high-performance microcontroller family
LITIX™ Basic	Scalable linear current sources family for automotive LED applications
Network transceivers	LIN and CAN transceivers
Position sensors	Magnetic position sensor and angle sensors



## Low-voltage motor control

Depending on a vehicle's specifications, a CAV is fitted with a brushless DC, brushed DC or unidirectional motor. Regardless of the motor type, every CAV requires robust low voltage motor control with the right selection of diagnostic and protective functions. This application, like many others, comes with its own set of challenges. In particular, the motor

control industry faces growing pressure to find new ways to increase energy efficiency. As software takes on a central role in motor control applications, the systems themselves are becoming more and more complex. Overcoming these challenges requires deep industry know-how coupled with leading-edge products and solutions.

# Brushless DC motor control

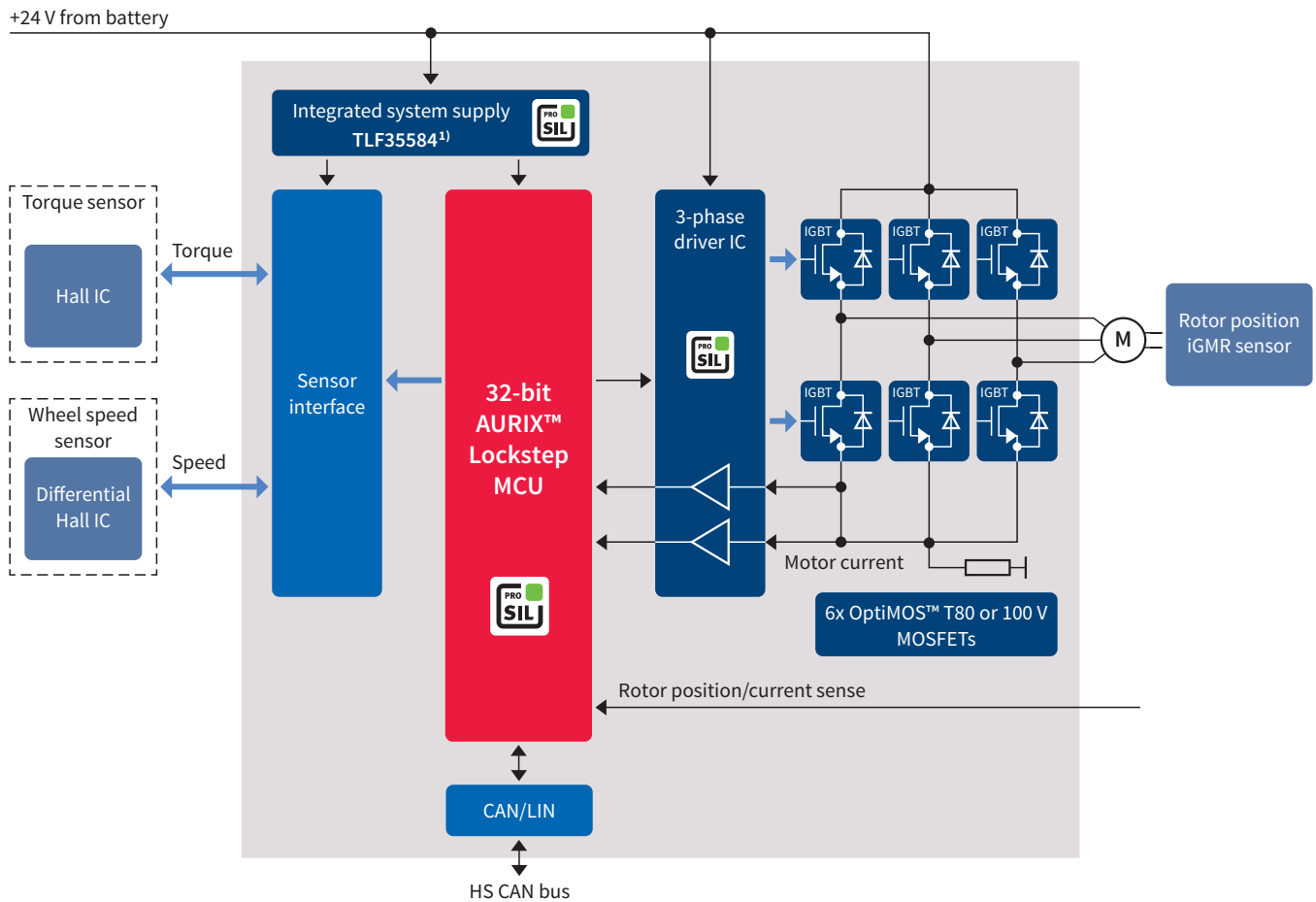

1) Requires external protection for  $V_{\text{Batt}} > 45\text{ V}$

## System benefits

- > Integrated solution reduces the design outlay
- > PWM control
- > Discrete solution optimized for all motors thanks to a broad selection of MOSFETs
- > Protection functions, including SC, overload, OT and ESD
- > Diagnostic functions, including open load, OT detection, integrated OPAMP and current sense



## Suggested products

Product family	Description
AURIX™	Scalable 32-bit TriCore™ microcontroller family from single to multicore (PRO-SIL™)
TLE9180	3-phase bridge driver IC for automotive safety applications (PRO-SIL™)
Position sensor	Magnetic position sensor and angle sensors
ATV and industrial MOSFETs 60/80/100 V	Single: n-channel 80 V/100 V MOSFET
TLF35584	System power supply with integrated watchdog (PRO-SIL™)
IKW/IKQxxN60/N120/T/H3	Discrete IGBT TO247/Plus 1200 V/600 V/8–120 A

# Brushed DC motor control

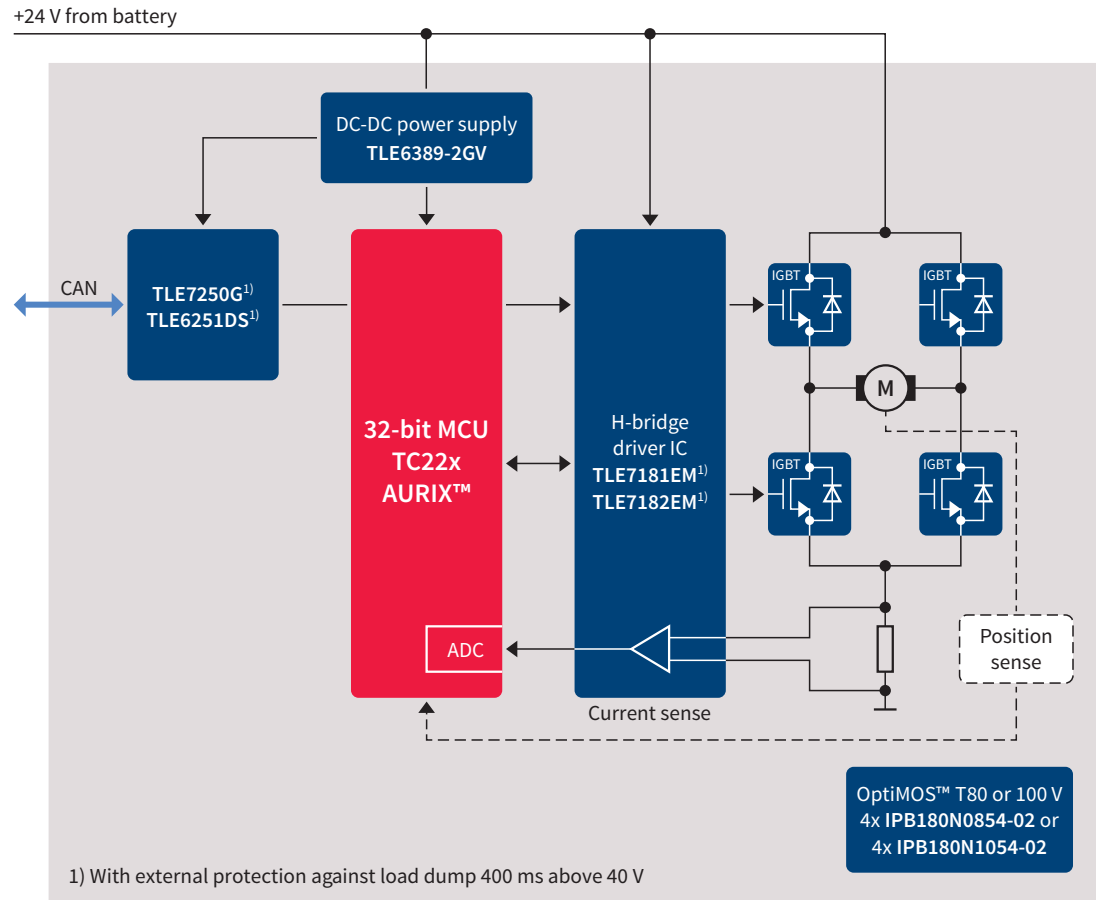

## System benefits

- > Integrated solution reduces the overall outlay
- > Discrete solution optimized for all motors thanks to a broad selection of MOSFETs
- > PWM control
- > Protection functions, including SC, overload, OT and ESD
- > Diagnostic functions, including open load, OT detection, integrated OPAMP and current sense

## Suggested products

Product family	Description
AURIX™	Scalable 32-bit TriCore™ microcontroller family from single to multicore (PRO-SIL™)
Network transceivers	CAN transceivers
Driver ICs TLE7181/7182	MOSFET driver for H-bridge configuration
ATV and industrial MOSFETs 60/80/100 V	Single: n-channel 80 V/100 V MOSFET
TLE6389	DC-DC converter (automotive) for 24 V applications
IKW/IKQxxN60/N120/T/H3	Discrete IGBT TO247/Plus 1200 V/600 V/8–120 A

# Unidirectional DC motor control

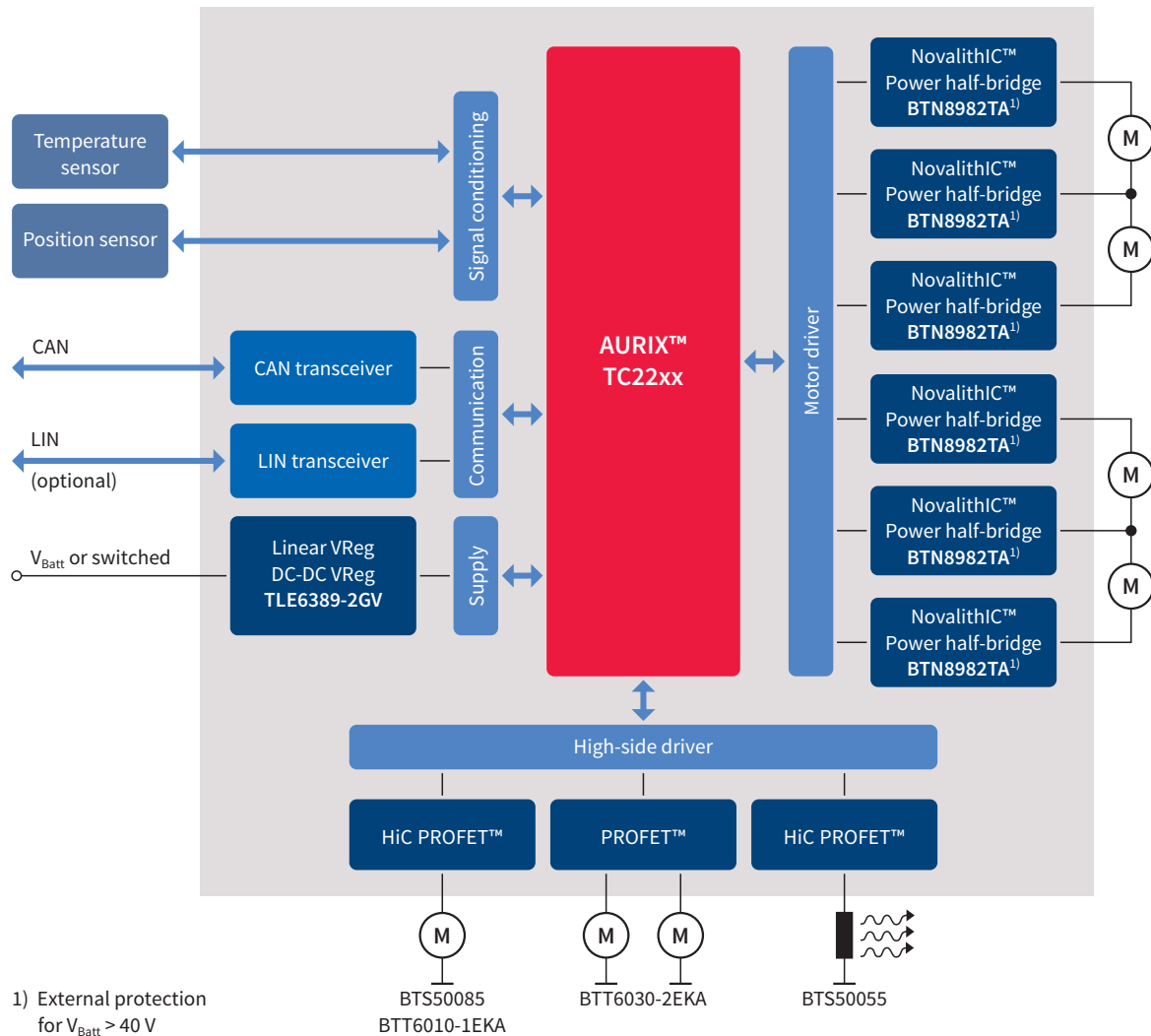

## System benefits

- > Integrated solution reduces design the design outlay
- > Discrete solution optimized for all motors thanks to a broad selection of PROFET™ switches
- > PWM control
- > Protection functions, including SC, overload, OT and ESD
- > Diagnostic functions, including open load, OT detection, integrated OPAMP and current sense

## Suggested products

Product family	Description
AURIX™ TC22xL	Scalable 32-bit TriCore™ microcontroller family from single to multicore (PRO-SIL™)
NovalithIC™ BTN8982TA	Integrated half-bridge driver
High-current PROFET™	Smart low-ohmic high-side switches for heating applications
PROFET™+ 24V	Smart high-side switches for 24 V applications
TLE6389	DC-DC converter (automotive)
Network transceivers	LIN and CAN transceivers



## Hybrid electric solutions

The latest generation of CAVs reflects trends like the drive for greater energy efficiency and better fuel economy. Electrification of drivetrains is a particularly attractive option because it helps manufacturers comply with ever-stricter emissions and energy efficiency legislation. Operators also benefit from electrification: it facilitates higher process efficiency and yield rates.

An electric drivetrain has far fewer parts, especially moving ones, resulting in fewer failures and maintenance issues. This makes electric drivetrains more reliable and productive. Using electric power instead of hydraulic in CAV auxiliary machines – such as saws, balers and mowers – enables higher speed and better accuracy and, therefore, greater productivity.

Fuel economy is a further advantage of hybrid and fully electric drivetrains. Fully electric engines do not rely on fossil fuels and contribute to a smaller carbon footprint, especially when charged with renewable energy. Electric vehicles improve driver and passenger comfort thanks to lower noise levels. Cities worldwide are becoming greener, cleaner and more livable thanks to vehicles that drive electric.

# Auxiliary applications

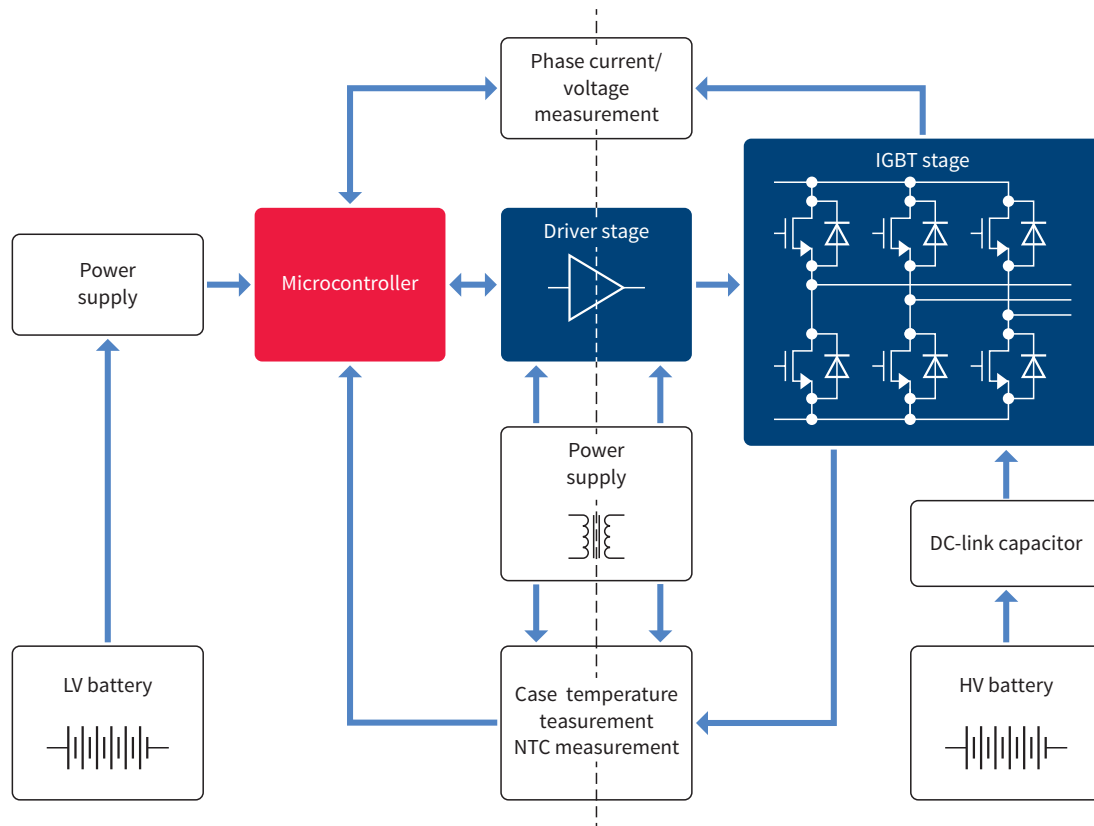

## System benefits

- › Power-product portfolio including both power module and discrete solutions
- › Gate drivers featuring galvanic isolation
- › Highly efficient 3-phase motor operation thanks to very low conduction losses, even at high switching frequencies
- › Broad 32-bit microcontroller solutions dedicated to (H)EV applications

## Suggested products

Product family	Description
FF600R12ME4A	EconoDUAL™ 3 half-bridge power module, 1200 V/600 A
FF900R12IP4V	PrimePACK™ 2 half-bridge power module 1200 V/900 A
FD/DF600R12IP4V	PrimePACK™ 2 high- and low-side chopper modules 1200 V/600 A
IKW/IKQxxN60/N120/T/H3	Discrete IGBT TO247/Plus 1200 V/600 V/8–120 A
2ED300C17-S/ST	Half-bridge high-power IGBT-driver
1ED020I12-FA	Single-channel IGBT-driver IC
2ED010I12-XXX	Dual-channel IGBT-driver IC



# Powertrain inverter

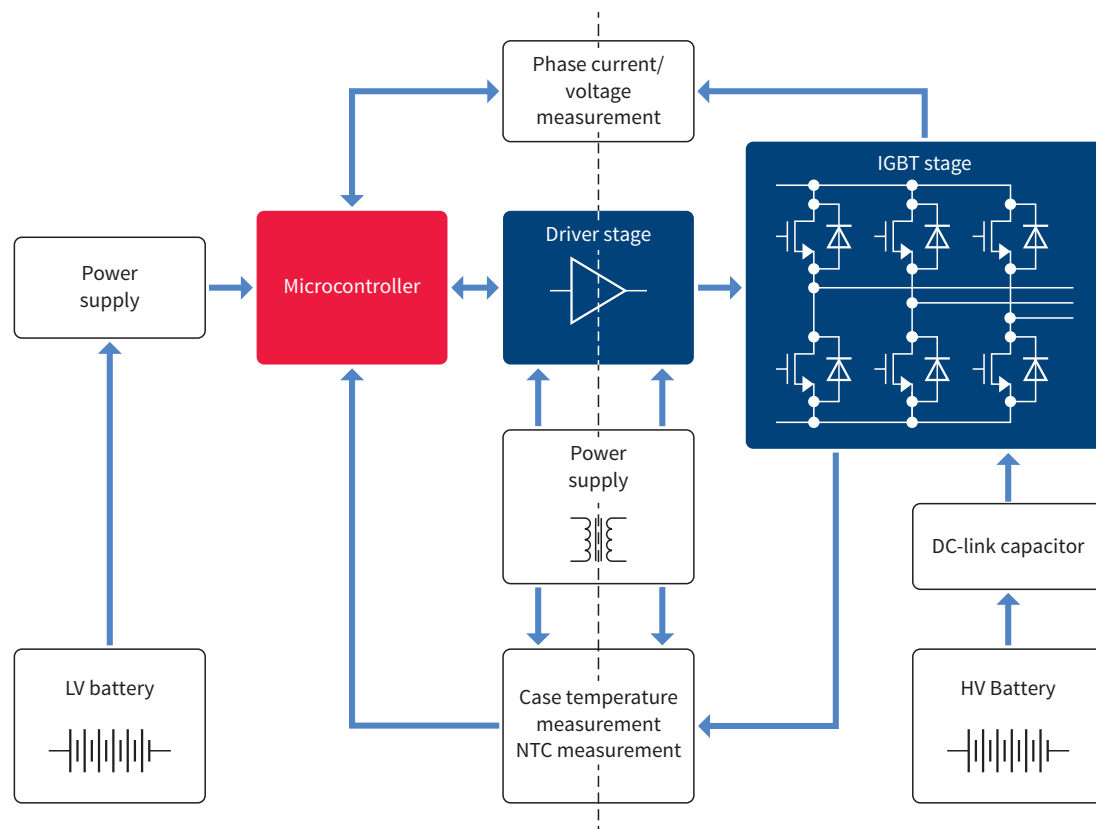

## System benefits

- > Product portfolio supports a wide range of motors, generators and power classes
- > Highly efficient 3-phase driver thanks to very low conduction losses, even at high switching frequencies
- > Isolation integrated in gate driver
- > Wide range of 32-bit microcontroller solutions dedicated to (H)EV applications, with an extremely cost-effective resolver interface

## Suggested products

Product family	Description
FF600R12ME4A	EconoDUAL™ 3 half-bridge power module, 1200 V/600 A
FF900R12IP4V	PrimePACK™ 2 half-bridge power module 1200 V/900 A
FD/DF600R12IP4V	PrimePACK™ 2 high- and low-side chopper modules 1200 V/600 A
IKW/IKQxxN60/N120/T/H3	Discrete IGBT TO247/Plus 1200 V/600 V/8-120 A
2ED300C17-S/ST	Half-bridge high-power IGBT-driver
1ED020I12-FA	Single-channel IGBT-driver IC
2ED010I12-XXX	Dual-channel IGBT-driver IC



## Valve control

Whether hydraulic or pneumatic, a control valve management system needs to demonstrate certain characteristics and be capable of executing certain functions in order to fulfill CAV demands. To efficiently control an inductive valve, a hydraulic management system has to be precise and robust enough to withstand harsh environments and engineered

to carry out a variety of protective and diagnostic functions. On the other hand, a pneumatic management system is typically chosen for its cost effectiveness and ease of integration (no need for a reservoir) compared to its hydraulic counterpart.

# Hydraulic management system

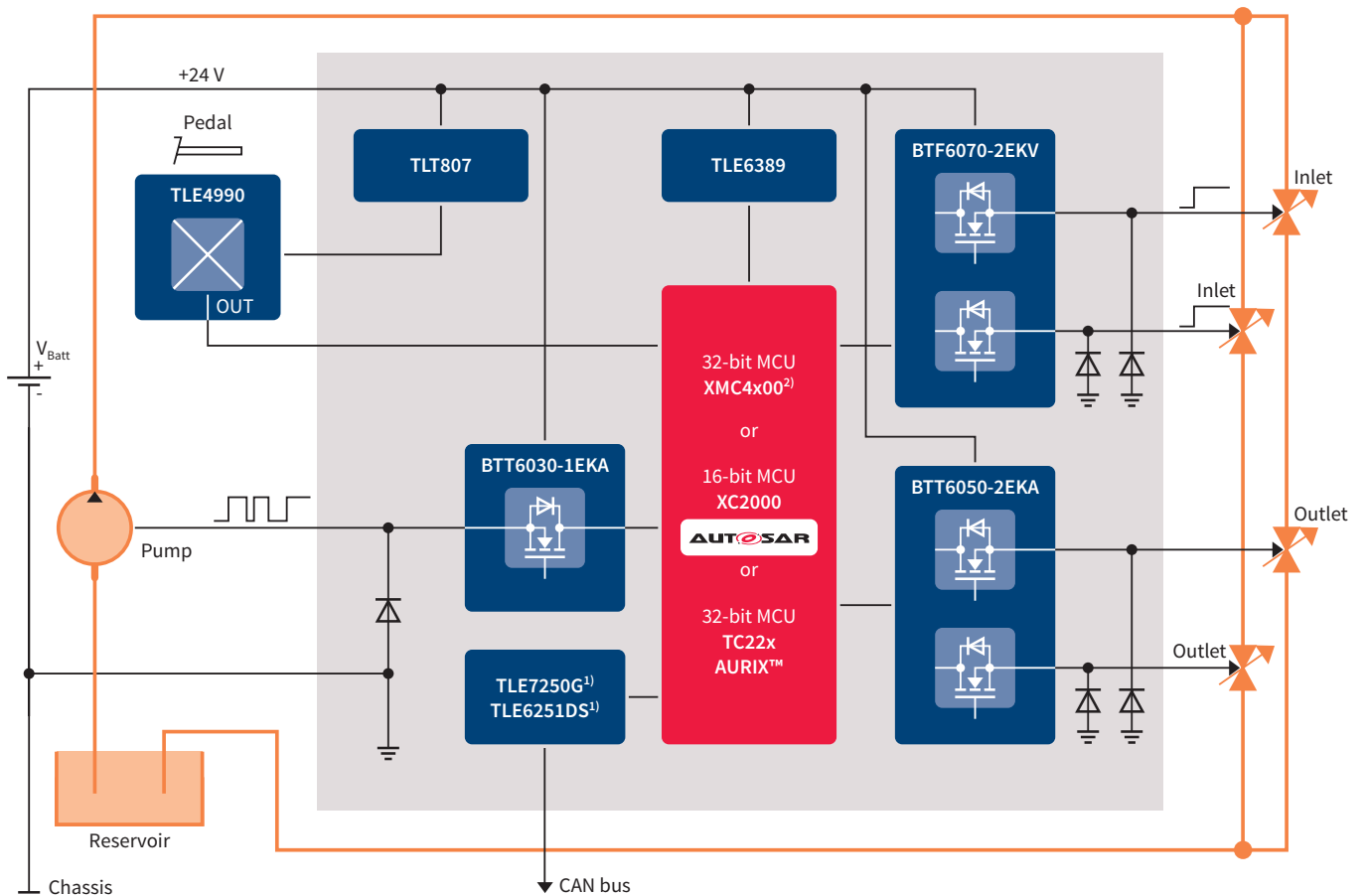

- 1) If the ECU is permanently supplied, you may need to add external protection against load dump 400 ms above 40 V.  
 2) Not AEC-Q100 qualified

## System benefits

- › Integrated solution reduces the design outlay
- › Pin-to-pin compatibility between the 12 and 24 V PROFET™+ families
- › Family concept with  $R_{DS(on)}$  scalability reduces the engineering outlay
- › Protection functions, including SC, overload, OT and ESD
- › Diagnostic functions, including open load, OT detection, integrated OPAMP and current sense
- › One-stop shop: supply, microcontrollers, actuators and sensors

## Suggested products

Product family	Description
AURIX™/XMC	32-bit high-performance microcontroller families (automotive/industrial)
PROFET™+ 24V	Smart high-side switches for 24 V applications and BTF6070-2EKV for fast switching control up to 2 kHz
Network transceivers	LIN and CAN transceivers
Hall sensors	Magnetic speed sensors
Supply ICs	Linear voltage regulator for 24 V: TLT807
TLE6389	DC-DC converter (automotive)

# Pneumatic management system

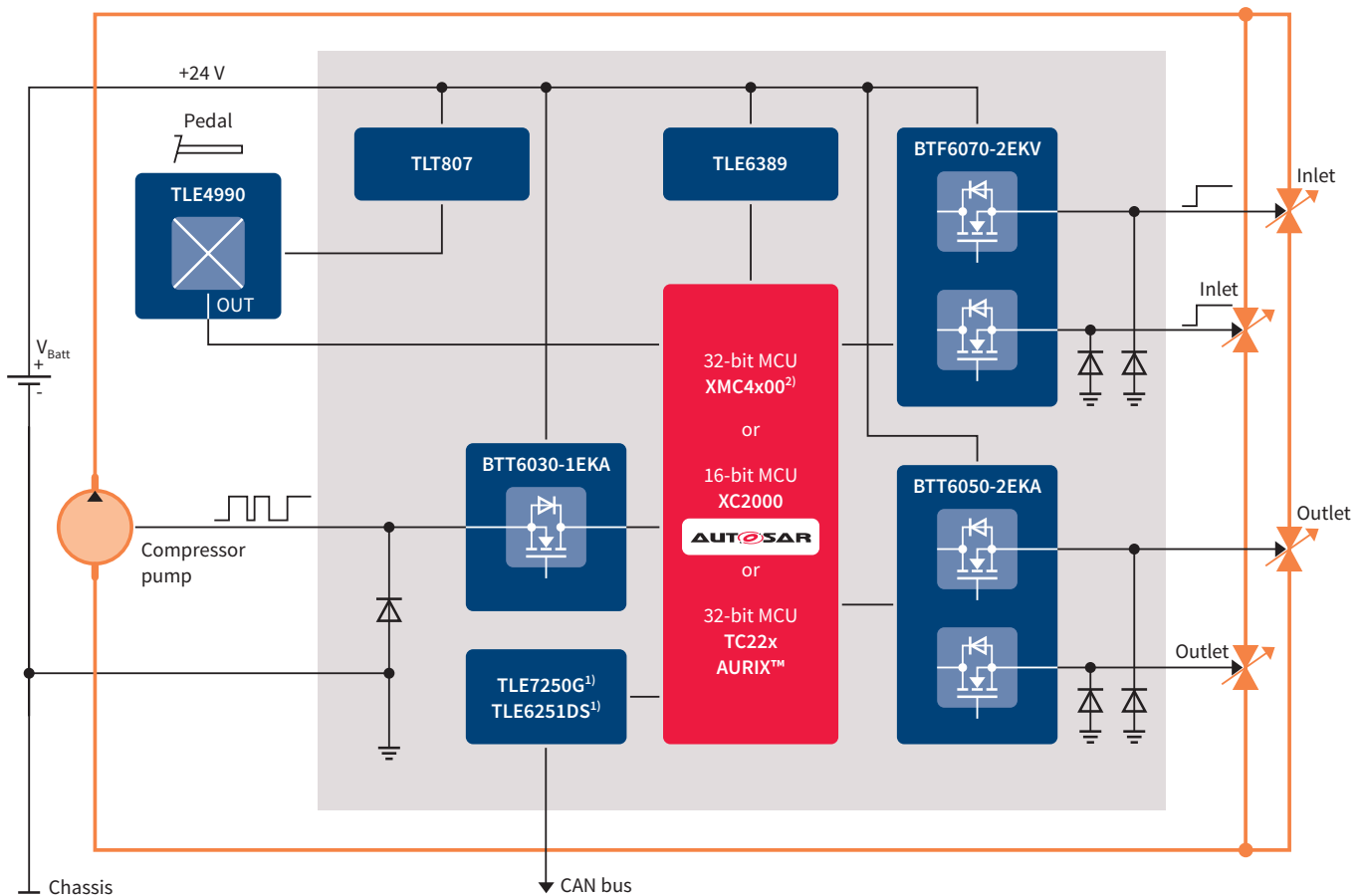

1) If the ECU is permanently supplied, you may need to add external protection against load dump 400 ms above 40 V.

2) Not AEC-Q100 qualified

## System benefits

- › Integrated solution reduces the design outlay
- › Pin-to-pin compatibility between the 12 and 24 V PROFET™+ families
- › Family concept with  $R_{DS(on)}$  scalability reduces the engineering outlay
- › Protection functions, including SC, overload, OT and ESD
- › Diagnostic functions, including open load, OT detection, integrated OPAMP and current sense
- › One-stop shop: supply, microcontrollers, actuators and sensors

## Suggested products

Product family	Description
AURIX™/XMC	32-bit high-performance microcontroller families (automotive/industrial)
PROFET™+ 24V	Smart high-side switches for 24 V applications and BTF6070-2EKV for fast switching control up to 2 kHz
Network transceivers	LIN and CAN transceivers
Hall sensors	Magnetic speed sensors
Supply ICs	Linear voltage regulator for 24 V: TLT807
TLE6389	DC-DC converter (automotive)

# Where to buy

Infiniteon distribution partners and sales offices:

[www.infineon.com/WhereToBuy](http://www.infineon.com/WhereToBuy)

# Service hotline

Infiniteon offers its toll-free 0800/4001 service hotline as one central number, available 24/7 in English, Mandarin and German.

- > Germany ..... 0800 951 951 951 (German/English)
- > China, mainland ..... 4001 200 951 (Mandarin/English)
- > India ..... 000 800 4402 951 (English)
- > USA ..... 1-866 951 9519 (English/German)
- > Other countries ..... 00\* 800 951 951 951 (English/German)
- > Direct access ..... +49 89 234-0 (interconnection fee, German/English)

\* Please note: Some countries may require you to dial a code other than "00" to access this international number.  
Please visit [www.infineon.com/service](http://www.infineon.com/service) for your country!



Mobile product catalog

Mobile app for iOS and Android.

[www.infineon.com](http://www.infineon.com)

Published by  
Infineon Technologies AG  
81726 Munich, Germany

© 2018 Infineon Technologies AG.  
All rights reserved.

Order number: B127-I0140-V2-7600-EU-EC-P  
Date: 02 / 2018

#### Please note!

THIS DOCUMENT IS FOR INFORMATION PURPOSES ONLY AND ANY INFORMATION GIVEN HEREIN SHALL IN NO EVENT BE REGARDED AS A WARRANTY, GUARANTEE OR DESCRIPTION OF ANY FUNCTIONALITY, CONDITIONS AND/OR QUALITY OF OUR PRODUCTS OR ANY SUITABILITY FOR A PARTICULAR PURPOSE. WITH REGARD TO THE TECHNICAL SPECIFICATIONS OF OUR PRODUCTS, WE KINDLY ASK YOU TO REFER TO THE RELEVANT PRODUCT DATA SHEETS PROVIDED BY US. OUR CUSTOMERS AND THEIR TECHNICAL DEPARTMENTS ARE REQUIRED TO EVALUATE THE SUITABILITY OF OUR PRODUCTS FOR THE INTENDED APPLICATION.

WE RESERVE THE RIGHT TO CHANGE THIS DOCUMENT AND/OR THE INFORMATION GIVEN HEREIN AT ANY TIME.

#### Additional information

For further information on technologies, our products, the application of our products, delivery terms and conditions and/or prices, please contact your nearest Infineon Technologies office ([www.infineon.com](http://www.infineon.com)).

#### Warnings

Due to technical requirements, our products may contain dangerous substances. For information on the types in question, please contact your nearest Infineon Technologies office.

Except as otherwise explicitly approved by us in a written document signed by authorized representatives of Infineon Technologies, our products may not be used in any life-endangering applications, including but not limited to medical, nuclear, military, life-critical or any other applications where a failure of the product or any consequences of the use thereof can result in personal injury.