



Chipsmall Limited consists of a professional team with an average of over 10 year of expertise in the distribution of electronic components. Based in Hongkong, we have already established firm and mutual-benefit business relationships with customers from,Europe,America and south Asia,supplying obsolete and hard-to-find components to meet their specific needs.

With the principle of “Quality Parts,Customers Priority,Honest Operation,and Considerate Service”,our business mainly focus on the distribution of electronic components. Line cards we deal with include Microchip,ALPS,ROHM,Xilinx,Pulse,ON,Everlight and Freescale. Main products comprise IC,Modules,Potentiometer,IC Socket,Relay,Connector.Our parts cover such applications as commercial,industrial, and automotives areas.

We are looking forward to setting up business relationship with you and hope to provide you with the best service and solution. Let us make a better world for our industry!



Contact us

Tel: +86-755-8981 8866 Fax: +86-755-8427 6832

Email & Skype: info@chipsmall.com Web: www.chipsmall.com

Address: A1208, Overseas Decoration Building, #122 Zhenhua RD., Futian, Shenzhen, China



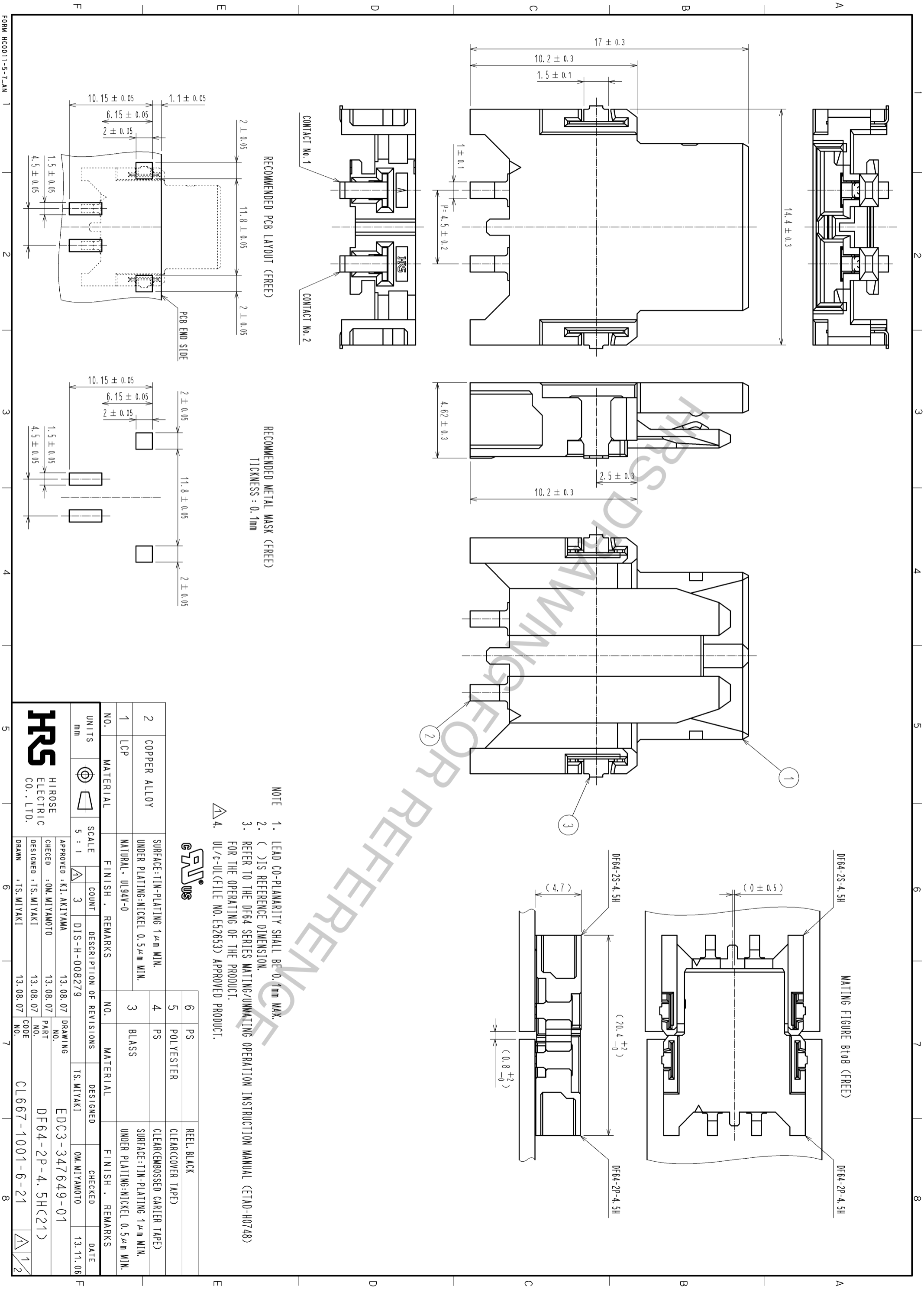

- NOTE
1. LEAD CO-PLANARITY SHALL BE 0.1mm MAX.
 2. () IS REFERENCE DIMENSION.
 3. REFER TO THE DF64 SERIES MATING/UNMATING OPERATION INSTRUCTION MANUAL (ETAD-H0748) FOR THE OPERATING OF THE PRODUCT.
 4. UL/c-UL(FILE NO. E52653) APPROVED PRODUCT.



NO.	UNITS	MATERIAL	FINISH	REMARKS	NO.	MATERIAL	FINISH	REMARKS
2	COPPER ALLOY			SURFACE:TIN-PLATING 1 μ m MIN. UNDER PLATING:NICKEL 0.5 μ m MIN.	4	PS	REEL, BLACK	
1	LCP			NATURAL, UL94V-0	5	POLYESTER	CLEARCOVER TAPE	
					3	BLASS	CLEAR(EMBOSSED CARRIER TAPE)	

UNITS	SCALE	COUNT	DESCRIPTION OF REVISIONS	DESIGNED	CHECKED	DATE
mm	5 : 1	3	DIS-H-008279	TS.MIYAKI	OM.MIYAMOTO	13.11.06

APPROVED	DESIGNED	CHECKED	DATE
KI.AKIYAMA	TS.MIYAKI	OM.MIYAMOTO	13.08.07

CHECKED	DESIGNED	PART NO.	DRAWING NO.
OM.MIYAMOTO	TS.MIYAKI	DF64-2P-4.5H(21)	EDC3-347649-01

DRAWN	NO.	CODE
TS.MIYAKI	13.08.07	CL667-1001-6-21



DRAWING FOR PACKING (2:1)

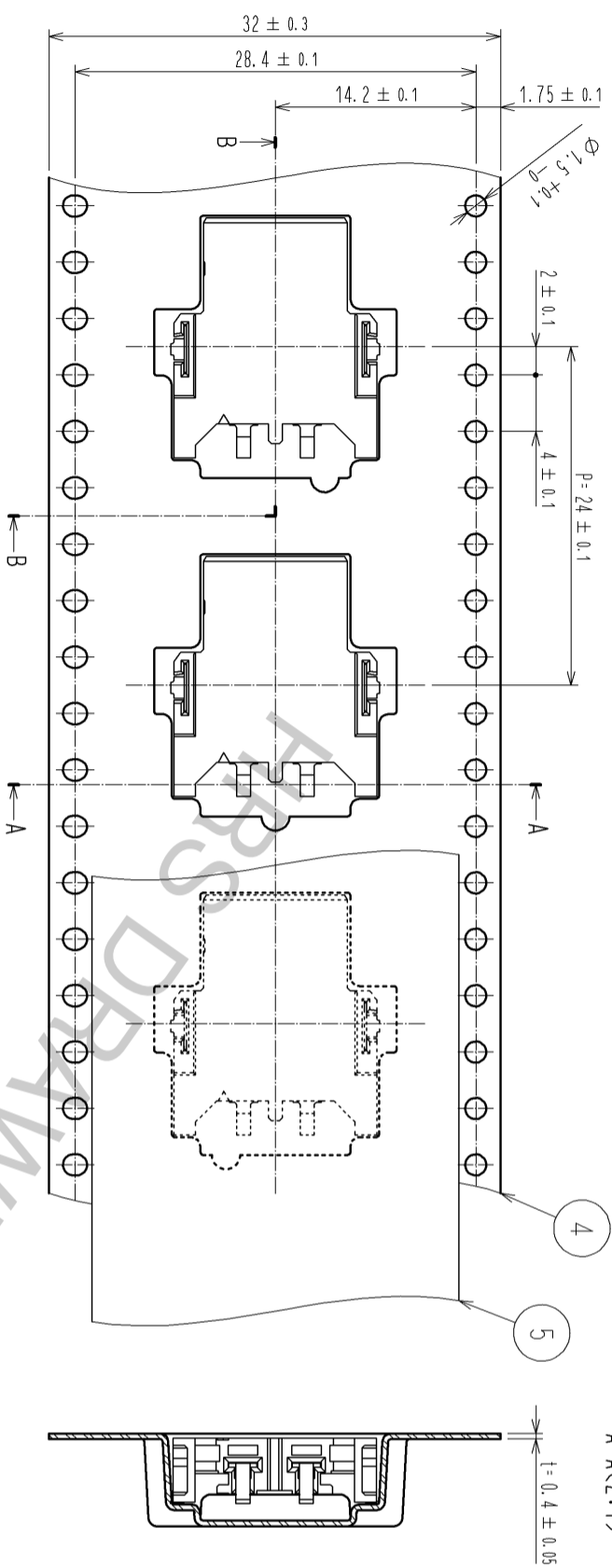

STYLE AND DIMENSION OF REEL(FREE)

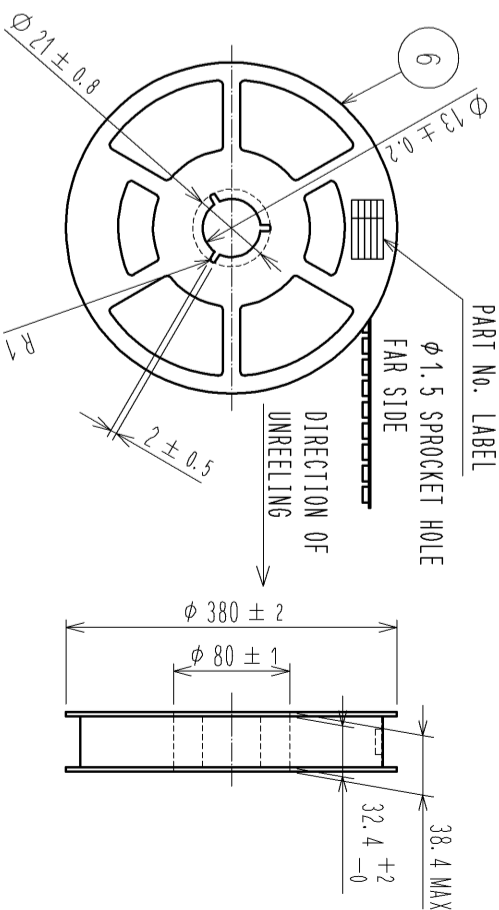

DETAIL OF PART NO. LABEL

生産月日	年	月	日
☑ 番	CL667-1001-6-21		
品名	DF64-2P-4.5H(21)		
納入数量	500 KO		
納入者	ヒロセ電機(株)		

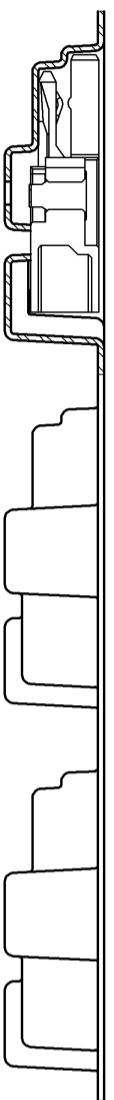

DIRECTION OF REELING →

B-B(2:1)

t (°C)

REFLOW TEMPERATURE PROFILE USING LEAD-FREE SOLDER PASTE (REFERENCE)

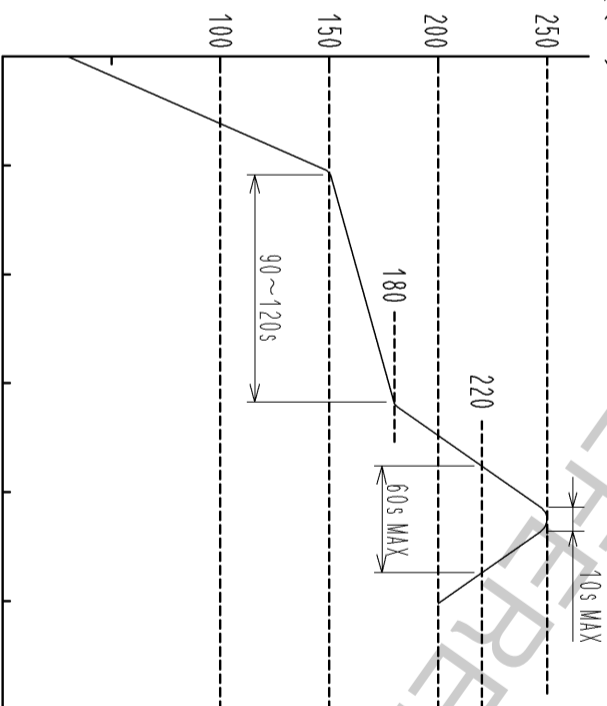

NUMBER OF REFLOW CYCLES 2 CYCLES MAX
 THE TEMPERATURE IS MEASURED IN THE TERMINAL LEAD PART.
 ADDITIONAL FACTORS, SUCH AS SOLDER PASTE TYPE,
 PCB SIZE AND OTHER MOUNTED COMPONENTS COULD AFFECT
 THE PROFILE.
 THEREFOR, A THOROUGH EVALUATION OF MOUNTING CONDITION IS
 REQUIRED PRIOR TO PRODUCTION.
 TEMPERATURE IS MEASURED AT CONTACT LEAD.

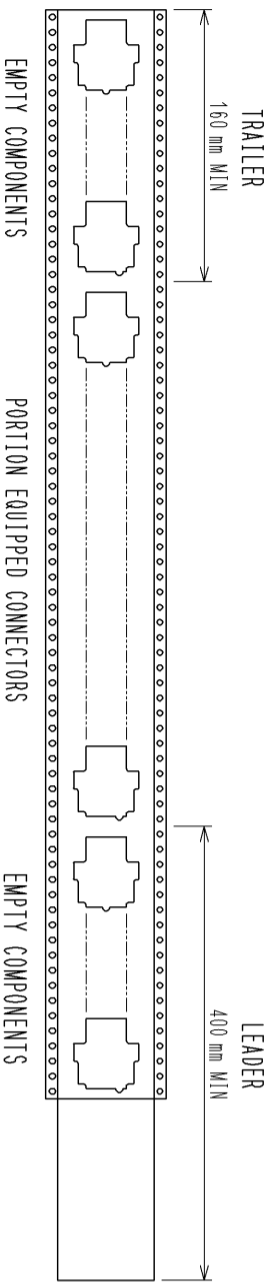

△6 TAPING(FREE)

△NOTE 5. 1REEL:500 CONNECTORS.

6 REEL TO JIS C 0806, (PACKAGING OF COMPONENTS FOR AUTOMATING HANDLING)
 7. () IS REFERENCE DIMENSION.

HRS

DRAWING NO.	EDC3-347649-01
PART NO.	DF64-2P-4.5H(21)
CODE NO.	CL667-1001-6-21