



Chipsmall Limited consists of a professional team with an average of over 10 year of expertise in the distribution of electronic components. Based in Hongkong, we have already established firm and mutual-benefit business relationships with customers from,Europe,America and south Asia,supplying obsolete and hard-to-find components to meet their specific needs.

With the principle of “Quality Parts,Customers Priority,Honest Operation,and Considerate Service”,our business mainly focus on the distribution of electronic components. Line cards we deal with include Microchip,ALPS,ROHM,Xilinx,Pulse,ON,Everlight and Freescale. Main products comprise IC,Modules,Potentiometer,IC Socket,Relay,Connector.Our parts cover such applications as commercial,industrial, and automotives areas.

We are looking forward to setting up business relationship with you and hope to provide you with the best service and solution. Let us make a better world for our industry!



Contact us

Tel: +86-755-8981 8866 Fax: +86-755-8427 6832

Email & Skype: info@chipsmall.com Web: www.chipsmall.com

Address: A1208, Overseas Decoration Building, #122 Zhenhua RD., Futian, Shenzhen, China



Description

The dual-output DFC15 Series of dc-dc converters are designed to provide a wide range of PCB power solutions where positive and negative outputs are required. The converter features fully isolated and filtered input and outputs for low noise. Trim and remote On/Off features give flexibility to designs. The ultra-wide input range, from 20 to 72 volts, allows use in most industrial and communication applications.

Features

- RoHS lead solder exemption compliant
- Remote on/off and trim
- Overcurrent and overtemperature protected
- Water-washable case
- Efficiencies to 82%
- 1544 V isolation
- Ultra-wide range input (>3:1)



Model Selection				
Model	Input Range VDC		Output VDC	Output mA
	Min	Max		
DFC15U48D12	20	72	±12	625
DFC15U48D15	20	72	±15	500

Model numbers highlighted in yellow or shaded are not recommended for new designs.

General Specifications (1)				
All Models				Units
ON/OFF Function (2)				
ON Logic Level or Leave Pin Floating	MIN	8.0	VDC	
Off Logic Level	MAX	2.0	VDC	
Input Resistance	TYP	100	Kohms	
Converter Idle Current ON/OFF Pin Low	TYP	2	mA	
Isolation (3)				
Breakdown Voltage 10 µA Leakage Input to Output	MIN	1544	VDC	
Input to Output Capacitance	TYP	450	pF	
Output Trim Function				
Input Resistance	TYP	40	Kohms	
Programming Range	MIN	+5, -34	%	
Environmental				
Case Functional Range, Tc No Derating	MIN MAX	-40 100	i C	
Storage Range	MIN MAX	-55 105	i C	
Thermal Impedance (4)	TYP	10	i C/Watt	
Thermal Shutdown Case Temperature	TYP	105	i C	
General				
MTBF (Calculated)	TYP	800,000	HRS	
Unit Weight	TYP	2.3/65	oz/gm	
Chassis Mounting Kit	CM2B2			

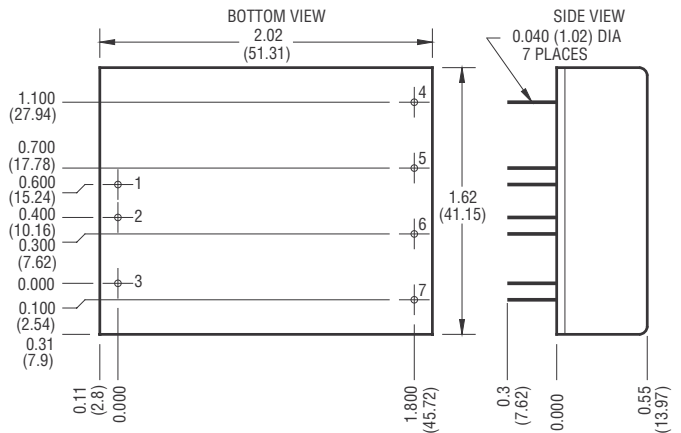

Mechanical tolerances unless otherwise noted:
X.XX dimensions: ±0.010 inches
X.XXX dimensions: ±0.005 inches

Pin	Function
1	+INPUT
2	-INPUT
3	ON/OFF
4	+OUTPUT
5	COMMON
6	-OUTPUT
7	TRIM

Notes

- (1) All parameters measured at Tc = 25 °C, nominal input voltage and full rated load unless otherwise noted.
- (2) The logic ON/OFF pin is Open Collector TTL, CMOS, and relay compatible. The input to this pin is referenced to Pin 2, -Input and is protected to +100 VDC.
- (3) Case is tied to Pin 1, + Input.
- (4) The case thermal impedance is specified as the case temperature rise over ambient per package watt dissipated.

Input Parameters (1)					
Model		DFC15U48D12		DFC15U48D15	Units
Voltage Range	MIN			20.0	VDC
	TYP			48.0	
	MAX			72.0	
Reflected Ripple (2) (3)	TYP			660	mA _{pp}
Input Current	Full Load	TYP	384	381	mA
	No Load	TYP	5	5	
Efficiency	TYP	81		82	%
Switching Frequency	TYP			120	kHz
Maximum Input Overvoltage 100ms	MAX			85	VDC
Turn-on Time, 1% Output Error	TYP			20	ms

Output Parameters (1)					
Model		DFC15U48D12		DFC15U48D15	Units
Output Voltage		±12		±15	VDC
Rated Load Range	MIN	0		0	mA
	MAX	625		500	
Voltage Range	MIN	11.900		14.900	VDC
	TYP	12.000		15.000	
	MAX	12.100		15.100	
Load Regulation (4) 0% -100% Full Load	TYP	0.15			%
	MAX	0.4			
Cross Regulation (5) 25%-100% Load	TYP	3.0			%
Line Regulation Vin = Min-Max VDC	TYP	0.04			%
	MAX	0.2			
Short Term Stability (6)	TYP	< 0.02			%/24Hrs
Long Term Stability	TYP	< 0.2			%/kHrs
Input Ripple Rejection (7)	TYP	>60			dB
Noise, 0-20MHz bw (2) with 0.1µF External Capacitor	TYP	30			mV _{pp}
	TYP	70			
Temperature Coefficient	TYP	50			ppm/°C
	MAX	150			
Overvoltage Clamp	TYP	18			VDC
Short Circuit Protection to Common for all Outputs	Continuous protection with current limiting and thermal overload techniques				

Notes

- (1) All Parameters measured at Tc=25 °C, nominal input voltage and full rated load unless otherwise noted.
- (2) Noise measurement bandwidth is 0-20 MHz.
- (3) An input capacitor must be used for proper operation of the converter. See the DFC15 Series Application Notes on sizing the input capacitor.
- (4) Load regulation for the outputs is specified as the voltage change when both outputs are changed from maximum to minimum at the same time.
- (5) Cross regulation is defined as the change in one output when the other output is changed from full load to 25% of full load. The converter can be run at no load on either or both outputs with no damage.
- (6) Short term stability is specified after a 60-minute warmup at full load, constant line and recording the drift over a 24-hour period.
- (7) The input ripple rejection is specified for DC to 120 Hz ripple with a modulation amplitude of 1% of Vin.

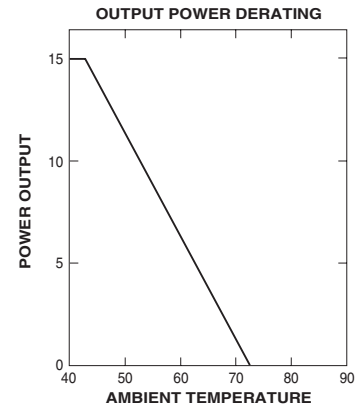
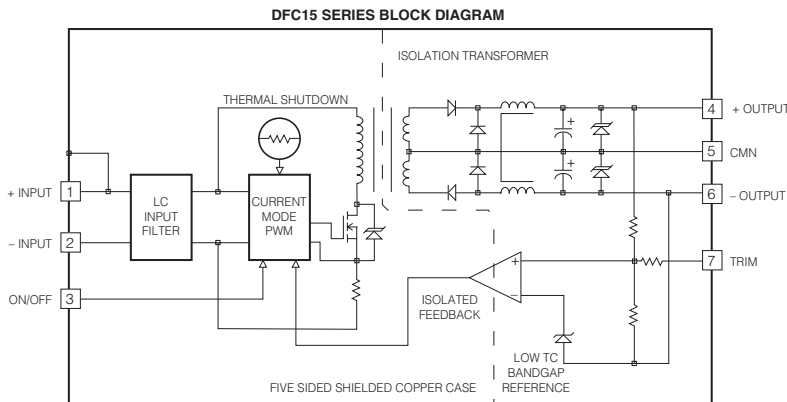

DFC15 Series Application Notes:

External Capacitance Requirements

An external capacitance is required for operation of the DFC15 Series. For maximum performance, it is recommended that the DFC15 Series use a capacitor of sufficient ripple current capacity connected across the input pins. To meet the reflected ripple requirements of the converter, an input impedance of less than 0.05 Ohms from DC to 200 kHz is required. External output capacitance is not required for operation, however it is recommended that 1 μ F to 10 μ F of tantalum and 0.001 to 0.1 μ F ceramic capacitance be selected for reduced system noise. Additional output capacitance may be added for increased filtering, but should not exceed 400 μ F.

Remote ON/OFF Operation

The remote ON/OFF pin may be left floating if this function is not used. It is recommended to drive this pin with an open collector arrangement or a relay contact. When the ON/OFF pin is pulled low with respect to the -INPUT, the converter is placed in a low power drain state. Do not drive this input from a logic gate directly; there is a 100KV internal pull-up resistor to a 9 volt source.

Output TRIM

The TRIM pin may be used to adjust the output +5% to -34% from the nominal setting. This function allows adjustment for voltage drops in the system wiring. As well 5.2 volt Figure 1 shows the proper connections to use this function. A trimpot value of 10KV or a fixed resistor may be used. If the TRIM function is not required the pin may be left floating.

Typical Performance: (Tc=25°C, Vin=Nom VDC, Rated Load)

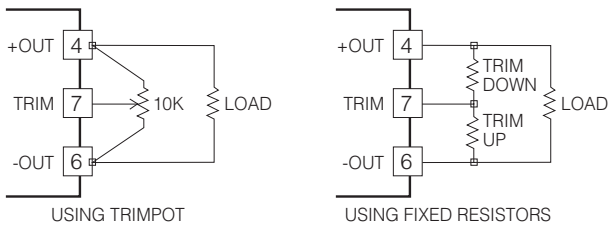
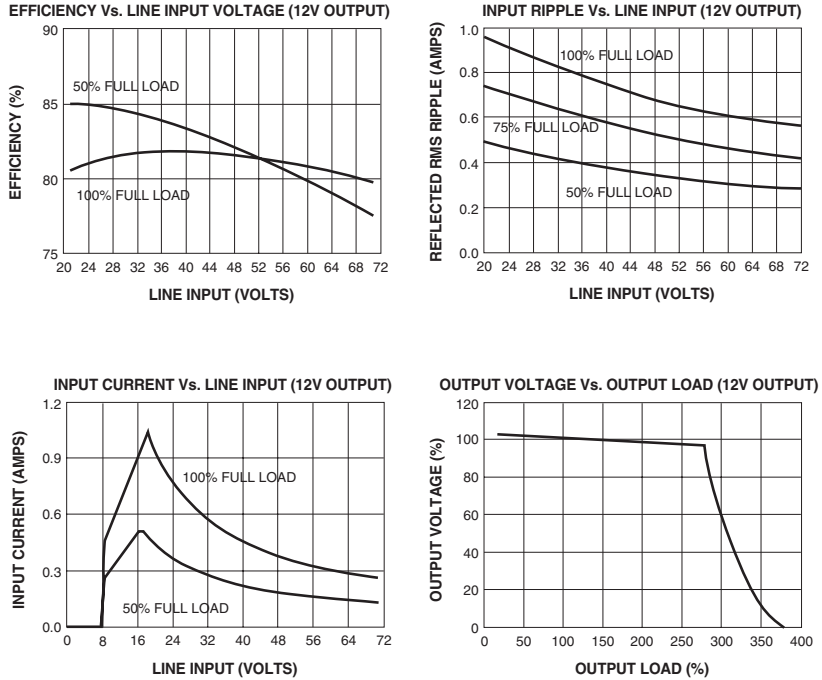
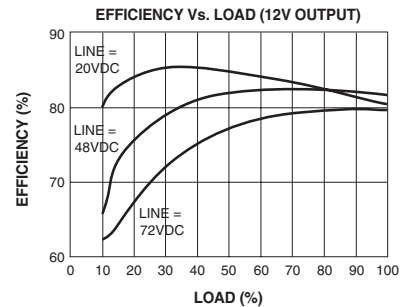

Figure 1.



NUCLEAR AND MEDICAL APPLICATIONS - Power-One products are not designed, intended for use in, or authorized for use as critical components in life support systems, equipment used in hazardous environments, or nuclear control systems without the express written consent of the respective divisional president of Power-One, Inc.

TECHNICAL REVISIONS - The appearance of products, including safety agency certifications pictured on labels, may change depending on the date manufactured. Specifications are subject to change without notice.